

# SCRUBTEC R 253 - RA40

---



---

## *Service Manual*

Nilfisk R 253, 9087362020 - 9087365020

Clarke RA40, 9087363020



English  
01/2015 revised 03/2016 (2)  
Form No. 910000402

# Contents

|  |           |
|--|-----------|
| <b>General Information . . . . .</b>   | <b>5</b>  |
| Machine General Description . . . . .  | 5         |
| Service Manual Purpose and Field of Application . . . . .                    | 5         |
| Other Reference Manuals . . . . .  | 5         |
| Conventions . . . . .  | 6         |
| Service and Spare Parts . . . . .  | 6         |
| Serial Number Label. . . . .   | 6         |
| Safety . . . . .   | 7         |
| Visible Symbols on the Machine. . . . .                                      | 7         |
| Symbols. . . . .   | 7         |
| General Instructions . . . . .   | 8         |
| Machine Lifting . . . . .  | 10        |
| Machine Transportation . . . . .   | 10        |
| Machine Nomenclature (know your machine) . . . . .                           | 11        |
| Control Panel. . . . .   | 13        |
| Service and Diagnostic Equipment . . . . .                                   | 14        |
| Technical Data . . . . .   | 15        |
| Dimensions . . . . .   | 16        |
| Scheduled Maintenance Table. . . . .   | 17        |
| <b>Chassis System . . . . .</b>  | <b>18</b> |
| Frame (main parts) . . . . .   | 18        |
| <b>Control System . . . . .</b>  | <b>19</b> |
| Functional Description. . . . .  | 19        |
| Wiring Diagram . . . . .   | 20        |
| Component Locations . . . . .  | 21        |
| Troubleshooting . . . . .  | 22        |
| Function Electronic Board (EB1) Alarm Codes. . . . .                         | 22        |
| Super User Screen . . . . .  | 27        |
| Alarm Log Screen . . . . .   | 27        |
| Setting Screen . . . . .   | 29        |
| Hours Screen. . . . .  | 31        |
| System for Flow Rate Adjustment as Function of Speed. . . . .                | 32        |
| Removal and Installation . . . . .   | 33        |
| Function Electronic Board (EB1) Removal/Replacement . . . . .                | 33        |
| Display Board (EB2) and Dashboard Instrument Board (EB4) Removal/Replacement | 35        |
| Specifications. . . . .  | 37        |
| Function Electronic Board (EB1) Connectors. . . . .                          | 37        |
| Display Electronic Board (EB2) Connectors . . . . .                          | 43        |
| Shop Measurements . . . . .  | 44        |
| Shop Measurements - Function Electronic Board (EB1) . . . . .                | 44        |
| Shop Measurements - Display Electronic Board (EB2) . . . . .                 | 51        |

|  |               |
|--|---------------|
| <b>Electrical System . . . . .</b>                               | <b>54</b>     |
| Functional Description . . . . .                                 | 54            |
| Battery Charger . . . . .  | 54            |
| Battery Charge State Display . . . . .                           | 54            |
| Wiring Diagram . . . . .   | 55            |
| Component Locations . . . . .                                    | 56            |
| Maintenance and Adjustments . . . . .                            | 58            |
| Setting the Installed Battery Type . . . . .                     | 58            |
| Battery installation . . . . .                                   | 60            |
| Battery Charging . . . . .                                       | 60            |
| Checking/Replacing Fuses . . . . .                               | 61            |
| Troubleshooting . . . . .  | 62            |
| Specifications . . . . .   | 63            |
| Wiring Diagram . . . . .   | 64            |
| <br><b>Options and Accessories . . . . .</b>                     | <br><b>65</b> |
| <br><b>Recovery System . . . . .</b>                             | <br><b>69</b> |
| Functional Description . . . . .                                 | 69            |
| Wiring Diagram . . . . .   | 69            |
| Component Locations . . . . .                                    | 70            |
| Maintenance and Adjustments . . . . .                            | 71            |
| Recovery Tank Cleaning . . . . .                                 | 71            |
| Troubleshooting . . . . .  | 72            |
| Vacuum System Motor Amperage Test . . . . .                      | 73            |
| Removal and Installation . . . . .                               | 74            |
| Vacuum System Motor Unit Disassembly/Assembly . . . . .          | 74            |
| Container and Vacuum System Motor Disassembly/Assembly . . . . . | 75            |
| Specifications . . . . .   | 78            |
| <br><b>Scrub System, Disc . . . . .</b>                          | <br><b>79</b> |
| Functional Description . . . . .                                 | 79            |
| RPM Brush Reduction Function . . . . .                           | 79            |
| Wiring Diagram . . . . .   | 80            |
| Component Locations . . . . .                                    | 81            |
| Brush Installation/Removal . . . . .                             | 83            |
| Troubleshooting . . . . .  | 84            |
| Brush Motor Amperage Check . . . . .                             | 85            |
| Removal and Installation . . . . .                               | 86            |
| Brush Deck Disassembly/Assembly . . . . .                        | 86            |
| Checking/Replacing Brush Motor Carbon Brushes . . . . .          | 88            |
| Brush Motor Disassembly/Assembly . . . . .                       | 89            |
| Brush Deck Actuator Disassembly/Assembly . . . . .               | 90            |
| Specifications . . . . .   | 91            |

|   |            |
|---|------------|
| <b>Solution System</b> . . . . .  | <b>92</b>  |
| Functional Description . . . . .  | 92         |
| Water Level Sensor Operation . . . . .                                  | 93         |
| Wiring Diagram . . . . .  | 94         |
| Component Locations . . . . .   | 95         |
| Maintenance and Adjustments . . . . .                                   | 97         |
| Cleaning the Solution Tank and Filter . . . . .                         | 97         |
| Cleaning the Chemical Mixing System Detergent Tank . . . . .            | 98         |
| Draining the Chemical Mixing System . . . . .                           | 99         |
| Troubleshooting . . . . .   | 100        |
| Checking the Water Level Sensor Operation . . . . .                     | 102        |
| Removal and Installation . . . . .                                      | 103        |
| Solenoid Valve Disassembly/Assembly . . . . .                           | 103        |
| Detergent Pump Disassembly/Assembly . . . . .                           | 104        |
| Water Level Sensor Disassembly/Assembly . . . . .                       | 105        |
| Specifications . . . . .  | 106        |
| <b>Squeegee System</b> . . . . .  | <b>107</b> |
| Functional Description . . . . .  | 107        |
| Wiring Diagram . . . . .  | 107        |
| Component Locations . . . . .   | 108        |
| Maintenance and Adjustments . . . . .                                   | 109        |
| Squeegee cleaning . . . . .   | 109        |
| Checking/Replacing the Squeegee Blades . . . . .                        | 110        |
| Troubleshooting . . . . .   | 111        |
| Removal and Installation . . . . .                                      | 112        |
| Squeegee Lifting Actuator Disassembly/Assembly . . . . .                | 112        |
| Squeegee Tie Rod Disassembly/Assembly . . . . .                         | 113        |
| Specifications . . . . .  | 114        |
| <b>Steering System</b> . . . . .  | <b>115</b> |
| Functional Description . . . . .  | 115        |
| Component Locations . . . . .   | 115        |
| Specifications . . . . .  | 116        |
| <b>Wheels, Drive System</b> . . . . .                                   | <b>117</b> |
| Functional Description . . . . .  | 117        |
| Wiring Diagram . . . . .  | 118        |
| Component Locations . . . . .   | 119        |
| Troubleshooting . . . . .   | 121        |
| Drive System Gearmotor Amperage Test . . . . .                          | 122        |
| Removal and Installation . . . . .                                      | 123        |
| Drive Pedal Potentiometer Disassembly/Assembly . . . . .                | 123        |
| Drive System Gearmotor Disassembly/Assembly . . . . .                   | 124        |
| Gearmotor Carbon Brushes Check/Replacement . . . . .                    | 125        |
| Drive System Motor Electromagnetic Brake Disassembly/Assembly . . . . . | 126        |
| Drive System Motor Disassembly/Assembly . . . . .                       | 127        |
| Specifications . . . . .  | 128        |

## General Information

### Machine General Description

The Scrubtec R 253 and Clarke RA40 are a “man on-board” industrial machine designed to wash and dry floors in one pass. The machine is powered by on-board batteries, models can be equipped with chemical mixing system. The machine features a variable floor pressure disc brush, controlled solution dosing and a rear squeegee with rubber blades that vacuums and dries the floor.

### Service Manual Purpose and Field of Application

The Service Manual is a technical resource intended to help service technicians when carrying out maintenance and repairs on the scrubbers, to guarantee the best cleaning performance and a long working life for the machine.

Please read this manual carefully before performing any maintenance and repair procedure on the machine.

### Other Reference Manuals

| Model                           | Product Code | User Manual | Spare Parts List |
|---------------------------------|--------------|-------------|------------------|
| Nilfisk Scrubtec R 253          | 9087362020   | 9100000391  | 9100000392       |
| Nilfisk Scrubtec R 253 full PKG | 9087365020   |             |                  |
| Clarke RA40                     | 9087363020   | 9100000394  |                  |

| Assembly Instructions            | Instruction Code | Machines concerned    |
|----------------------------------|------------------|-----------------------|
| Chemical Mixing System Kit       | 9100000953       | Scrubtec R 253 - RA40 |
| Battery charger kit              | 9100001068       | Scrubtec R 253        |
| Waste basket kit                 | 9100001067       | Scrubtec R 253        |
| Broom holder kit                 | 9100000985       | Scrubtec R 253        |
| Enhanced vacuum system motor kit | 9100000968       | Scrubtec R 253        |
| Water filler hose kit            | 9100001072       | Scrubtec R 253 - RA40 |
| Stop water kit                   | 9100000984       | Scrubtec R 253 - RA40 |
| Beacon light kit                 | 9100000982       | Scrubtec R 253 - RA40 |
| USB kit                          | 9100000983       | Scrubtec R 253 - RA40 |
| Trackclean kit                   | 9100001061       | Scrubtec R 253 - RA40 |

These manuals are available at:

- Local Nilfisk or Clarke retailer
- Nilfisk website: [www.nilfisk.com](http://www.nilfisk.com)
- Clarke website: [www.clarkeus.com](http://www.clarkeus.com)

### Conventions

Forward, backward, front, rear, left or right are intended with reference to the operator’s position, that is to say in driving position.

### Service and Spare Parts

Service and repairs must be performed only by authorised personnel or Nilfisk or Clarke Service Centers. The authorised personnel is trained directly at the manufacturer’s premises and has original spare parts and accessories.

Contact Nilfisk or Clarke Retailer indicated below for service or to order spare parts and accessories, specifying the machine model and serial number.

(Apply Retailer label here)

### Serial Number Label

Reference to Figure 1

The machine serial number and model name are marked on the plate (see the example to the side). Product code and year of production are marked on the same plate.

This information is useful when requiring machine spare parts. Use the following table to write down the machine identification data.

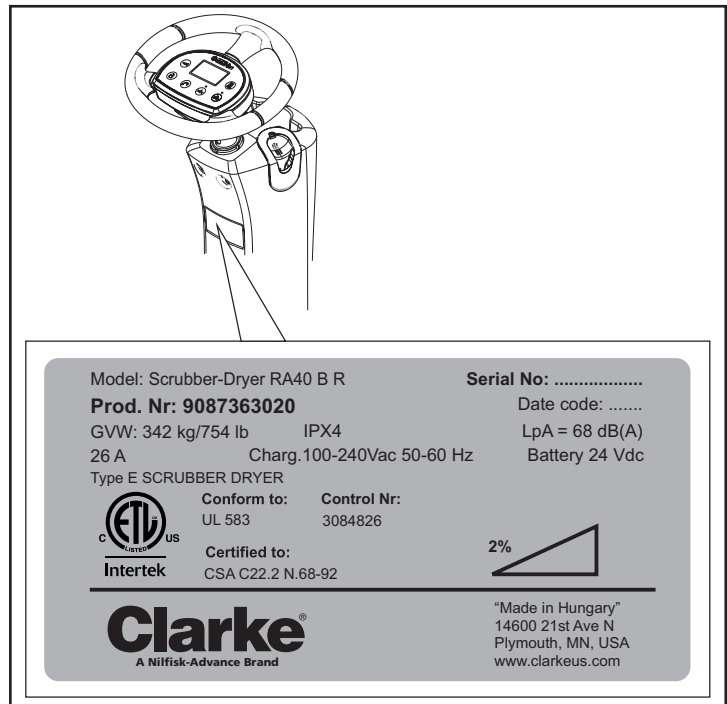


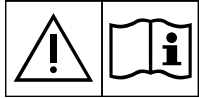
Figure 1

|                             |
|-----------------------------|
| MACHINE model .....         |
| PRODUCT code .....          |
| MACHINE serial number ..... |

## Safety

The following symbols indicate potentially dangerous situations. Always read this information carefully and take all necessary precautions to safeguard people and property.

### Visible Symbols on the Machine



**Warning!** *Carefully read all the instructions before performing any operation on the machine.*



**Warning!** *Do not wash the machine with direct or pressurized water jets.*



**Warning!** *Do not use the machine on slopes with a gradient exceeding the specifications.*

## Symbols



**Note:** *It indicates a remark related to important or useful functions.*



**Danger!** *It indicates a dangerous situation with risk of death for the operator.*



**Warning!** *It indicates a potential risk of injury for people or damage to objects.*



**Caution!** *It indicates a caution related to important or useful functions.*

## General Instructions

Specific warnings and cautions to inform about potential damages to people and machine are shown below.



**Warning!** *Make sure to follow the safety precautions to avoid situations that may lead to serious injuries.*

- Before performing any maintenance, repair, cleaning or replacement procedure, remove the ignition key and disconnect the battery connector.
- This machine must be used by properly trained operators only.
- Do not wear jewels when working near electrical components.
- Do not work under the lifted machine without supporting it with safety stands.
- Do not operate the machine near toxic, dangerous, flammable and/or explosive powders, liquids or vapors. This machine is not suitable for collecting dangerous powders.
- When using lead (WET) batteries, keep sparks, flames and smoking materials away from the batteries. During the normal operation explosive gases are released.
- When using lead (WET) batteries, battery charging produces highly explosive hydrogen gas. During battery charging, lift the recovery tank and perform this procedure in well-ventilated areas and away from naked flames.



**Caution!** *Make sure to follow the safety precautions to avoid situations that may lead to serious injuries, damages to materials or equipments.*

- Carefully read all the instructions before performing any maintenance/repair procedure.
- Before using the battery charger, ensure that frequency and voltage values, indicated on the machine serial number plate, match the electrical mains voltage.
- Do not pull or carry the machine by the battery charger cable and never use the battery charger cable as a handle. Do not close a door on the battery charger cable, or pull the battery charger cable around sharp edges or corners. Do not run the machine on the battery charger cable.
- Keep the battery charger cable away from heated surfaces.
- Do not charge the batteries if the battery charger cable or the plug are damaged.
- To reduce the risk of fire, electric shock, or injury, do not leave the machine unattended when it is plugged in. Before performing any maintenance procedure, disconnect the battery charger cable from the electrical mains.
- Do not smoke while charging the batteries.
- To avoid any unauthorized use of the machine, remove the ignition key.
- Do not leave the machine unattended without being sure that it cannot move independently.
- Always protect the machine against the sun, rain and bad weather, both under operation and inactivity condition. This machine must be used in dry conditions, it must not be used or kept outdoors in wet conditions.
- Before using the machine, close all doors and/or covers as shown in the User Manual.
- This machine is not intended for use by persons (including children) with reduced physical, sensory or mental capabilities, or lack of experience and knowledge, unless they have been given supervision or instruction concerning use of the machine by a person responsible for their safety.
- Children should be supervised to ensure that they do not play with the machine.
- Close attention is necessary when used near children.
- Use only as shown in this Manual. Use only Nilfisk or Clarke recommended accessories.



- Check the machine carefully before each use, always check that all the components have been properly assembled before use. If the machine is not perfectly assembled it can cause damages to people and properties.
- Take all necessary precautions to prevent hair, jewels and loose clothes from being caught by the machine moving parts.
- Do not use the machine on slopes.
- Do not tilt the machine more than the angle indicated on the machine itself, in order to prevent instability.
- Do not use the machine in particularly dusty areas.
- Use the machine only where a proper lighting is provided.
- If the machine is to be used where there are other people besides the operator, it is necessary to install the beacon light (optional).
- While using this machine, take care not to cause damage to people or objects.
- Do not bump into shelves or scaffoldings, especially where there is a risk of falling objects.
- Do not lean liquid containers on the machine, use the relevant can holder.
- The machine operating temperature must be between 32 °F and 104 °F (0 °C and +40 °C).
- The machine storage temperature must be between 32 °F and 104 °F (0 °C and +40 °C).
- The humidity must be between 30 % and 95 %.
- When using floor cleaning detergents, follow the instructions on the labels of the detergent bottles.
- To handle floor cleaning detergents, wear suitable gloves and protections.
- Do not use the machine as a means of transport.
- Do not allow the brush/pad to operate while the machine is stationary to avoid damaging the floor.
- In case of fire, use a powder fire extinguisher, not a water one.
- Do not tamper with the machine safety guards and follow the ordinary maintenance instructions scrupulously.
- Do not allow any object to enter into the openings. Do not use the machine if the openings are clogged. Always keep the openings free from dust, hairs and any other foreign material which could reduce the air flow.
- Do not remove or modify the plates affixed to the machine.
- To manually move the machine, the electromagnetic brake must be disengaged. After moving the machine manually, engage the electromagnetic brake again. Do not use the machine when the electromagnetic brake handwheel is screwed down.
- When the machine is to be pushed for service reasons (missing or discharged batteries, etc.), the speed must not exceed 2.5 mi/h (4 km/h).
- This machine cannot be used on roads or public streets.
- Pay attention during machine transportation when temperature is below freezing point. The water in the recovery tank or in the hoses could freeze and seriously damage the machine.
- Use brushes and pads supplied with the machine or those specified in the User Manual. Using other brushes or pads could reduce safety.
- In case of machine malfunctions, ensure that these are not due to lack of maintenance. If necessary, request assistance from the authorised personnel or from an authorised Service Center.
- If parts must be replaced, require ORIGINAL spare parts from an Authorised Dealer or Retailer.
- To ensure machine proper and safe operation, the scheduled maintenance shown in the relevant chapter of this Manual, must be performed by the authorised personnel or by an authorised Service Center.
- Do not wash the machine with direct or pressurised water jets, or with corrosive substances.
- The machine must be disposed of properly, because of the presence of toxic-harmful materials (batteries, etc.), which are subject to standards that require disposal in special centres (see Scrapping chapter).

## **Machine Lifting**



**Warning!** Do not work under the lifted machine without supporting it with safety stands.

## **Machine Transportation**



**Warning!** Before transporting the machine, make sure that:

*All covers are closed.*

*The recovery tank and the detergent tank are empty.*

*The batteries are disconnected.*

*The ignition key is removed.*

*The machine is securely fastened to the means of transport.*

### Machine Nomenclature (know your machine)

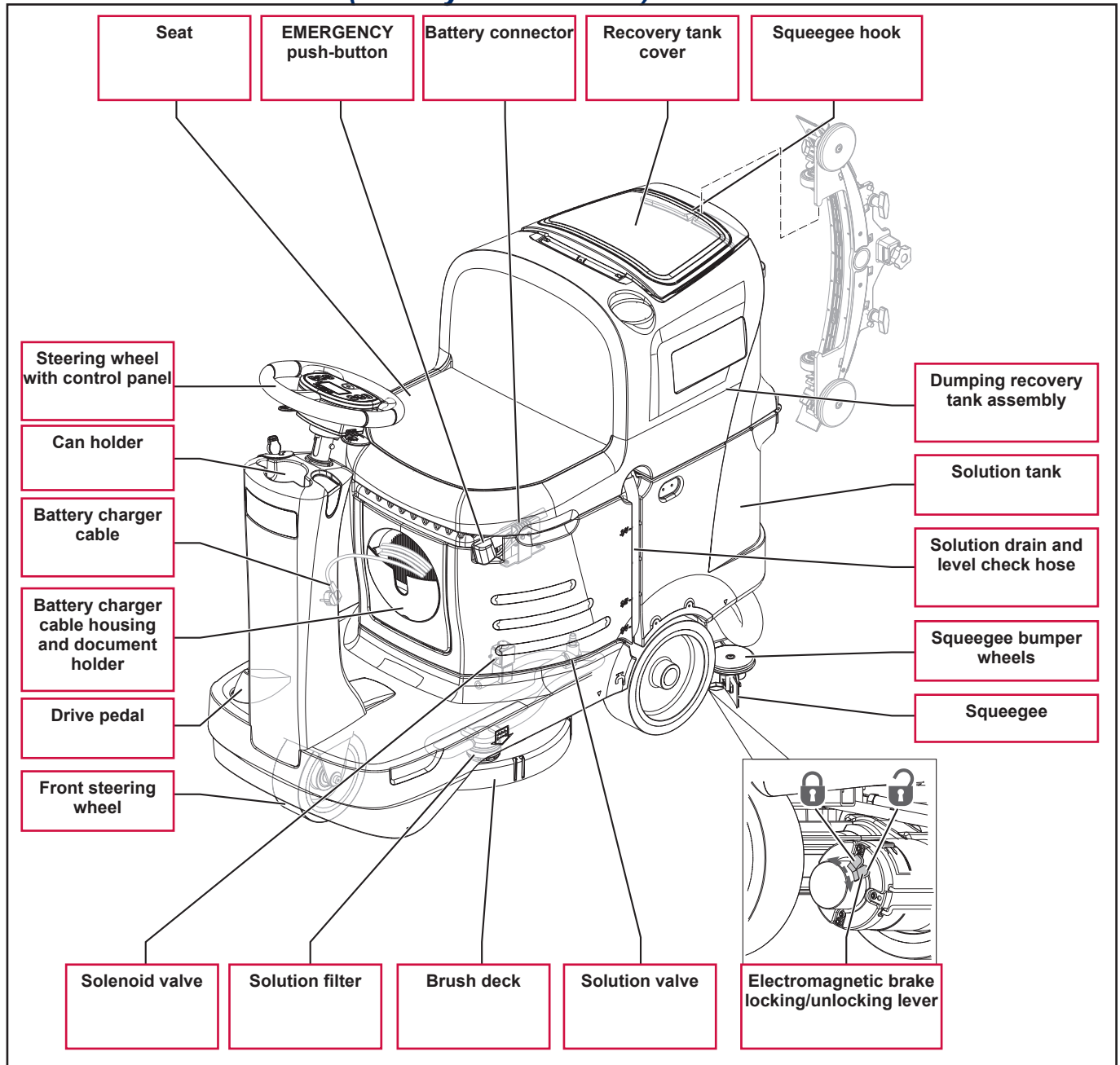


Figure 2

### Machine Nomenclature (Continues)

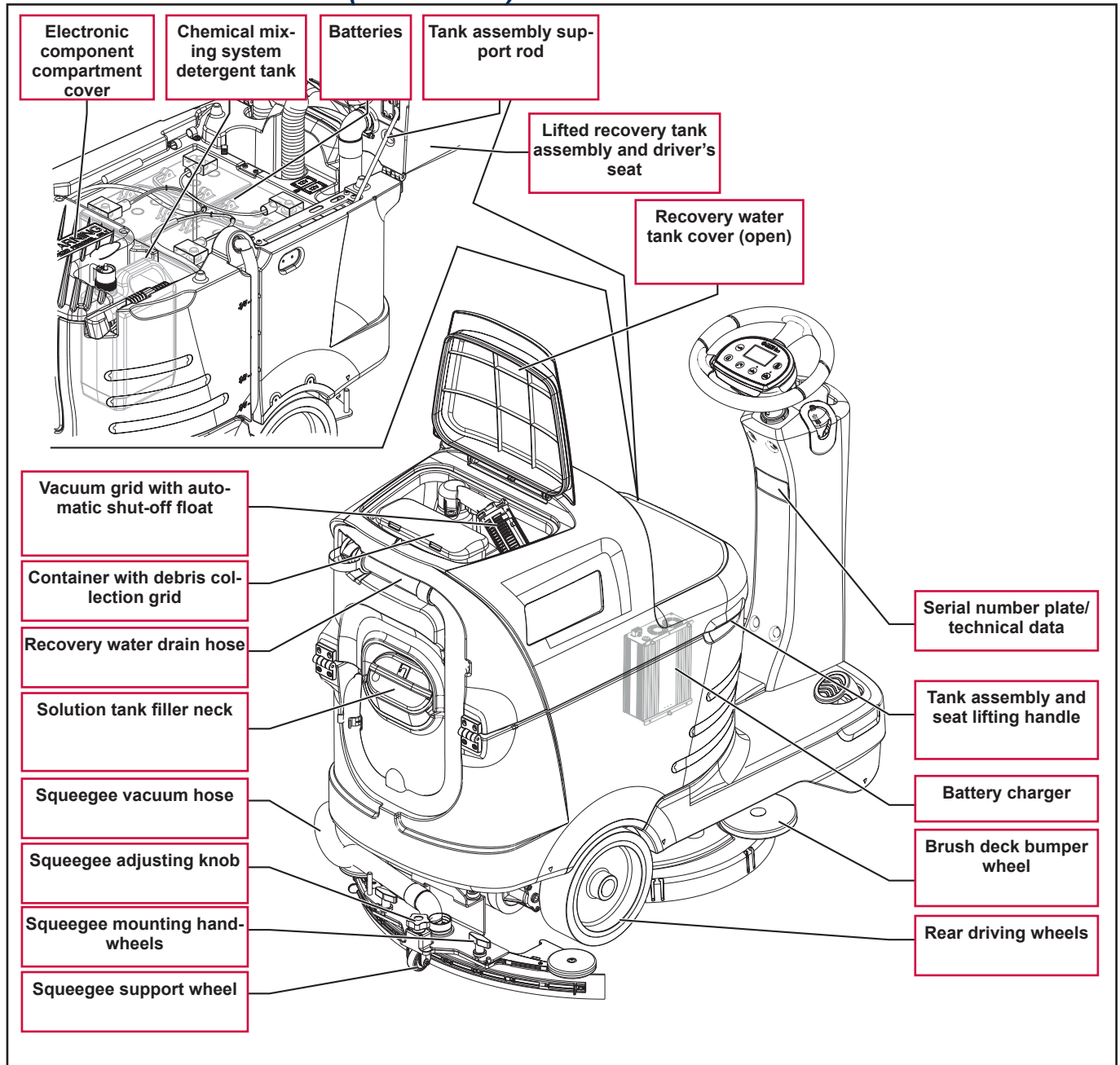


Figure 3

## Control Panel

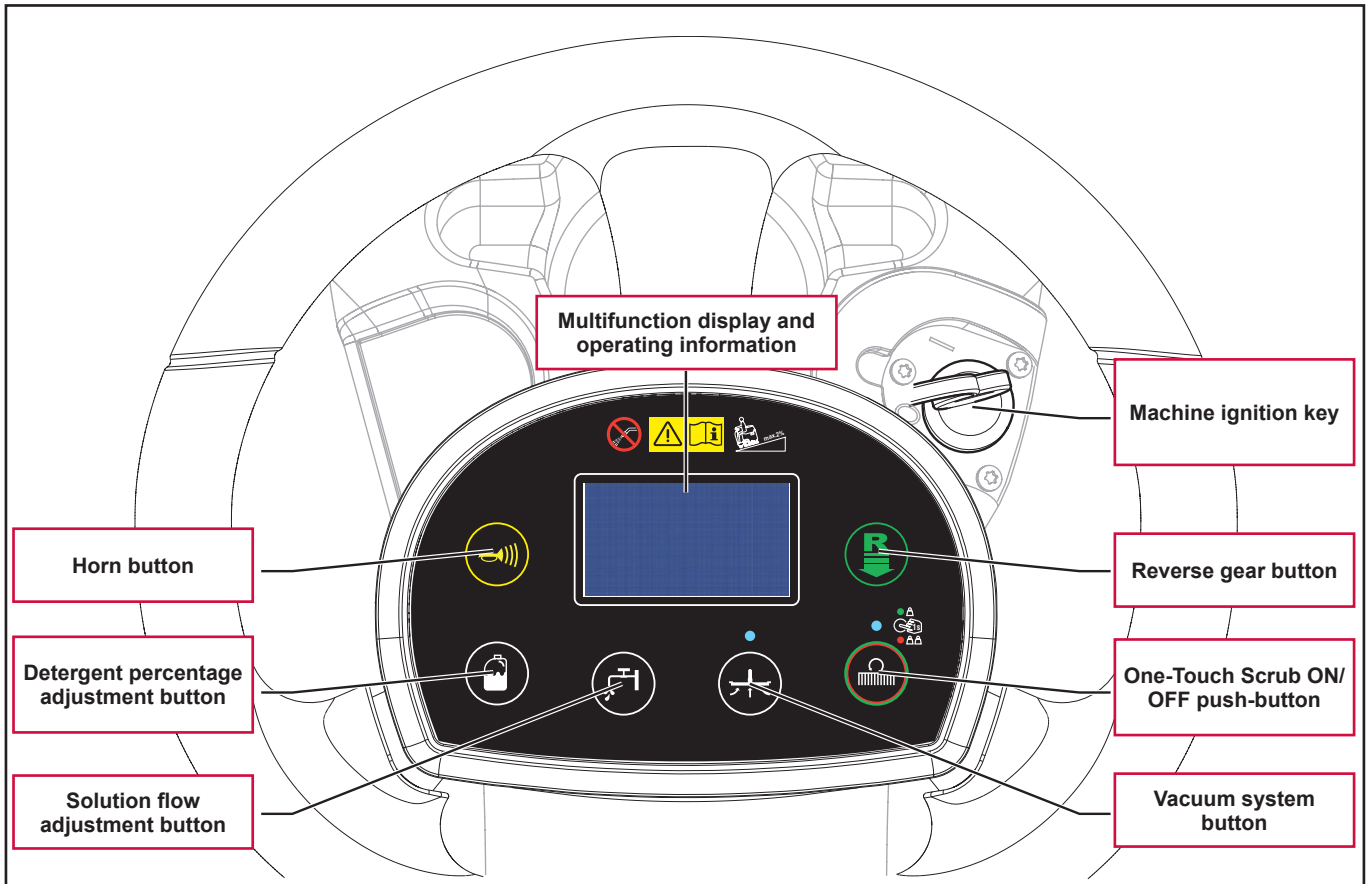


Figure 4

## Service and Diagnostic Equipment

Besides a complete set of standard meters, the following instruments are necessary to perform fast checks and repairs on Nilfisk Clarke machines:

- Laptop computer charged with the current version of EzParts, Adobe Reader and (if possible) Internet connection
- Digital Volt Meter (DVM)
- Amp clamp with possibility of making DC measurements
- Hydrometer
- Battery charge tester to check 12V batteries
- Static control wrist strap
- Dynamometric wrench set
- A copy of the User Manual and Spare Parts List of the machine to be serviced (provided with the machine or available at [www.nilfisk.com](http://www.nilfisk.com) and [www.clarkeus.com](http://www.clarkeus.com) or other Nilfisk Clarke websites).

The following equipment is also available at Nilfisk Clarke Centers:

- Vacuum water lift gauge, P/N 56205281

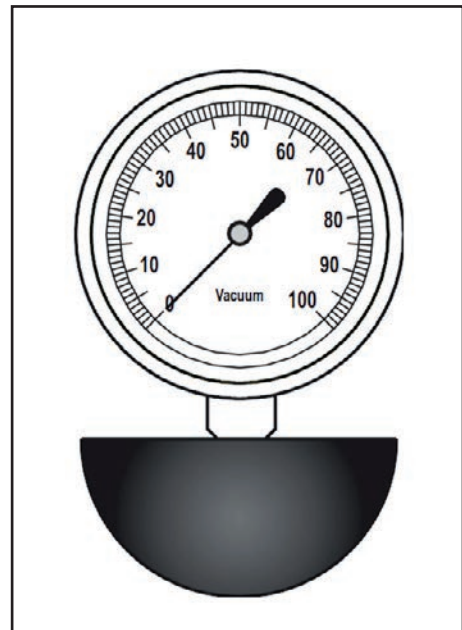


Figure 5

## Technical Data

| Description / Model  | Nilfisk<br>Scubtec R253                                   | Nilfisk<br>Scubtec R253 full PKG<br>Clarke RA40 |
|--|---|---|
| Solution tank capacity   | 18,5 US gal (70 liters)                                   |   |
| Recovery tank capacity   | 18,5 US gal (70 liters)                                   |   |
| Machine length   | 50 in (1270 mm)   |   |
| Machine width with squeegee  | 28.3 in (720 mm)  |   |
| Machine width without squeegee   | 21.6 in (550 mm)  |   |
| Machine height   | 40.1 in (1020 mm)   |   |
| Turning space for U-turns  | 71 in (1800 mm)   |   |
| Cleaning width   | 21 in (530 mm)  |   |
| Rear driving wheel diameter  | 10 in (254 mm)  |   |
| Rear driving wheel specific pressure on the floor (*)                          | 145 psi (1,0 N/mm <sup>2</sup> )                          |   |
| Front steering wheel diameter  | 7.9 in (200 mm)   |   |
| Front wheel specific pressure on the floor (*)                                 | 189 psi (1,3 N/mm <sup>2</sup> )                          |   |
| Brush/pad diameter   | 21 in (530 / 508 mm)                                      |   |
| Brush pressure   | 33 lb (15 kg)   |   |
| Brush pressure (extra pressure on)   | 66 lb (30 kg)   |   |
| Solution flow values   | 0,75 cl/m / 1,5 cl/m / 3,0 cl/m / (2,8 l/min, if enabled) |   |
| Chemical Mixing System detergent percentage                                    | Ratio 1:500 ÷ 1:33 (0,25% ÷ 3%)                           |   |
| Sound pressure level at workstation (ISO 11201, ISO 4871, EN 60335-2-72) (LpA) | 68 ±3 dB(A)   |   |
| Machine sound power level (ISO 3744, ISO 4871, EN 60335-2-72) (LwA)            | 84 dB(A)  |   |
| Vibration level at the operator's arms (ISO 5349-1, EN 60335-2-72)             | 130 in/s <sup>2</sup> (3,3 m/s <sup>2</sup> )             |   |
| Vibration level at the operator's body (ISO 5349-1, EN 60335-2-72)             | 35.4 in/s <sup>2</sup> (0,9 m/s <sup>2</sup> )            |   |
| Maximum gradient when working  | 2%  |   |
| Drive system motor power   | 0.53 hp (400 W)   |   |
| Drive speed (variable)   | 0 - 3.7 mi/h (0 - 6 km/h)                                 |   |
| Vacuum system motor power  | 0.4 hp (310 W)  |   |
| Vacuum system circuit capacity   | 39 in H <sub>2</sub> O (1000 mm H <sub>2</sub> O)         |   |
| Brush motor power  | 0.6 hp (450 W)  |   |
| Brush rotation speed   | 155 rpm   |   |
| Total power draw (EN 60335-2-72)   | 26 A (620 W)  |   |
| IP protection class  | X4  |   |
| Protection class (electric)  | III (I for the battery charger)                           |   |
| Battery compartment size   | 13.8x14.2x11 in (350x360x280 mm)                          |   |
| System voltage   | 24 V  |   |
| Standard batteries (2)   | Discover 12V-105Ah  |   |
| Battery charger  | 100-240Vac 50-60Hz, 24Vdc 13A                             |   |
| Operating time (standard batteries) (EN 60335-2-72)                            | 2,5 h   |   |
| Weight without batteries and with empty tanks                                  | 262 lb (119 kg)   | 267 lb (121 kg)                                 |
| Gross vehicle weight (GVW)   | 754 lb (342 kg)   |   |
| Shipping weight  | 342 lb (152 kg)   | 502 lb (228 kg) Nilfisk 342 lb (155 kg) Clarke  |

(\*) Machines have been tested under the following conditions:

- Battery maximum size
- Maximum brush and squeegee size
- Full detergent tank
- Optional equipment installed
- Wheel weight checked
- Print on the floor checked on cement for each single wheel
- Result expressed as maximum value for both front and rear wheels

## Dimensions

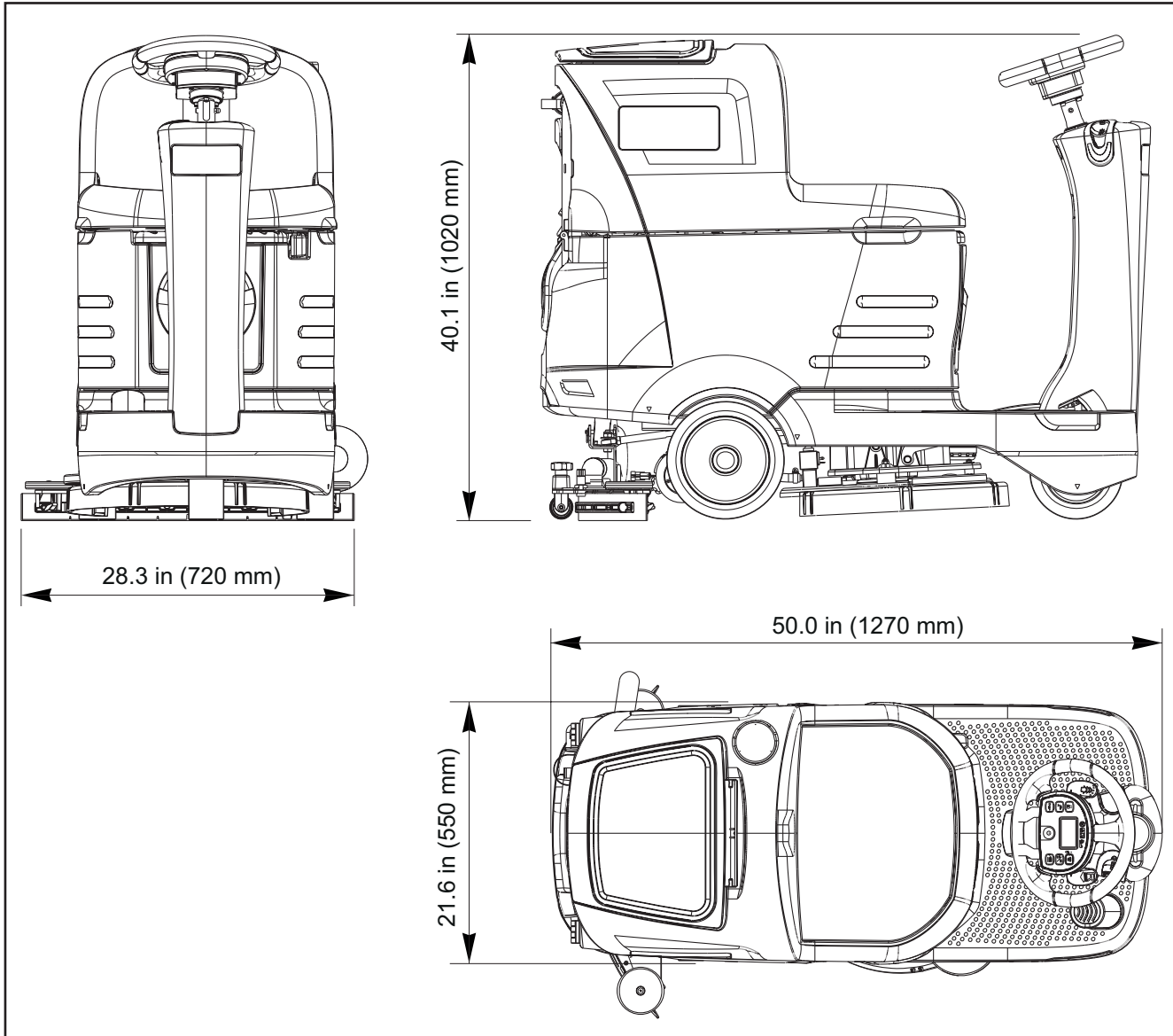


Figure 6



## Maintenance

The lifespan of the machine and its maximum operating safety are ensured by correct and regular maintenance.



**Warning!** *Read carefully the instructions in the Safety chapter before performing any maintenance procedure.*

The following tables provides the scheduled maintenance. The intervals shown may vary according to particular working conditions, which are to be defined by the person in charge of the maintenance.

For instructions on maintenance procedures, see the following paragraphs.

### Scheduled Maintenance Table

| Procedure  | Daily, after using the machine | Weekly | Every six months | Yearly |
|--|--------------------------------|--------|------------------|--------|
| Battery Charging   |                                |        |                  |        |
| Squeegee Cleaning  |                                |        |                  |        |
| Brush/pad cleaning   |                                |        |                  |        |
| Recovery tank and debris tray cleaning, and cover gasket check |                                |        |                  |        |
| Chemical Mixing System cleaning and draining                   |                                |        |                  |        |
| Squeegee blade check   |                                |        |                  |        |
| Solution filter cleaning                                       |                                |        |                  |        |
| Battery (WET) fluid level check                                |                                |        |                  |        |
| Squeegee blade replacement                                     |                                |        |                  |        |
| Electromagnetic brake efficiency check                         |                                |        |                  |        |
| Brush motor carbon brush check or replacement                  |                                |        |                  |        |
| Drive system motor carbon brush check or replacement           |                                |        |                  |        |

## Chassis System

### Frame (main parts)

Reference to Figure 1

- Steering assembly/column support plate and deck mount
- Main support side member
- Gearmotor support plate and squeegee system mount

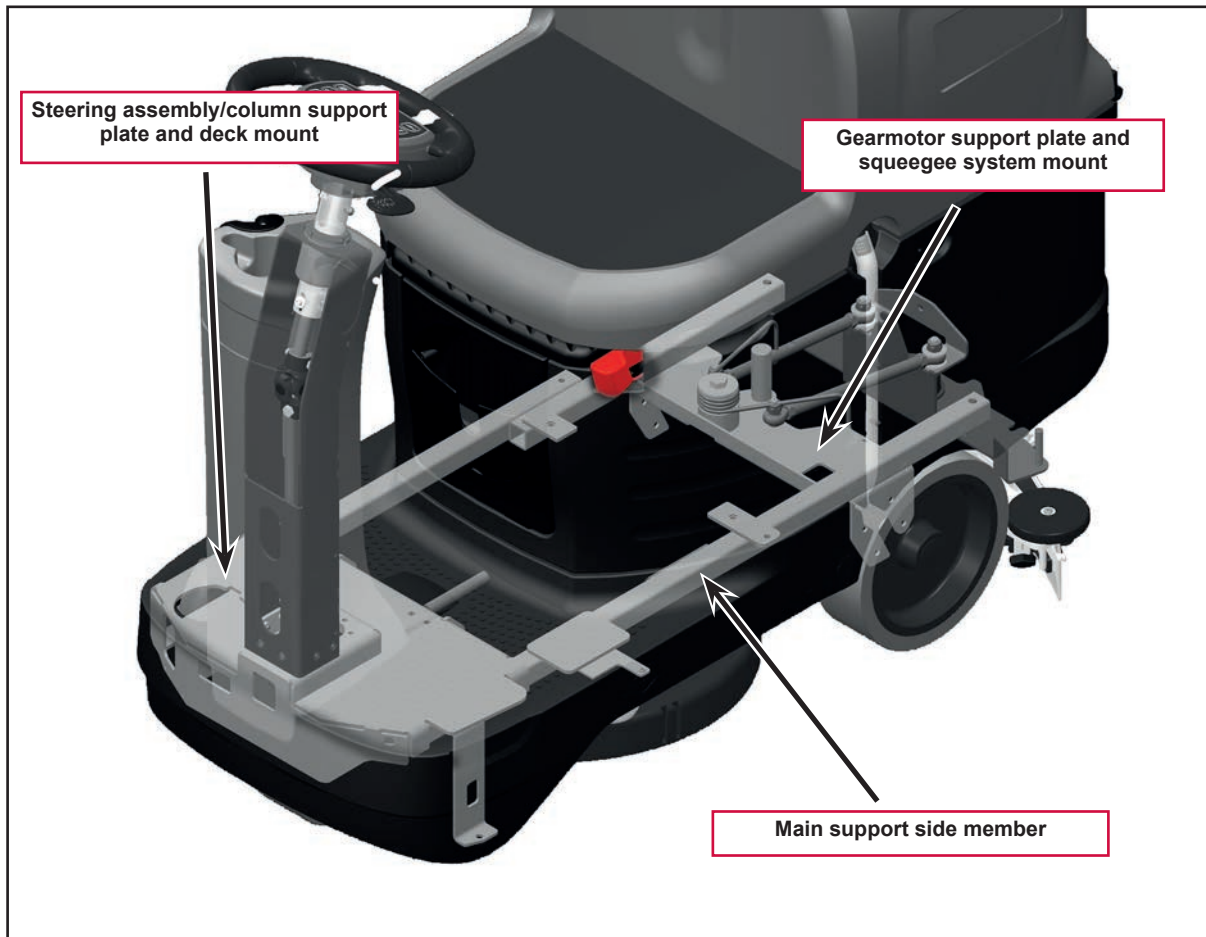


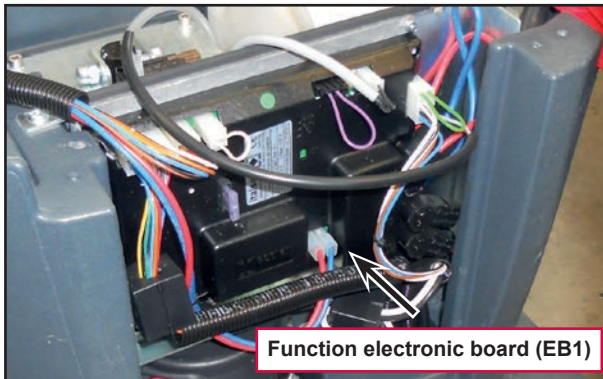
Figure 1

## Control System

### Functional Description

The architecture of the electronic control system for the machine's electrical components is composed of a function electronic board (EB1) and a display electronic board (EB2), in turn connected to a dashboard instrument electronic board (EB4) which represents the main user interface.

The function electronic board (EB1)

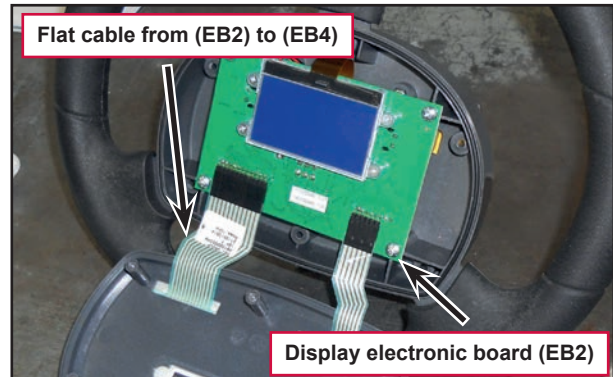


manages all components and drives the following components directly:

- Brush motor (M1)
- Vacuum system motor (M2)
- Drive system motor (M3) with the relevant Electromagnetic brake (BRK)
- Detergent pump (M4)
- Deck actuator (M5)
- Squeegee actuator (M6)
- Solution flow solenoid valve (EV1)

The horn and the beep reverse is an integral part of the function electronic board (EB1).

The display electronic board (EB2)



serves mainly as an aggregator for all input signals (buttons) and outputs (LEDs) from the dashboard instrument electronic board (EB4),



which it is connected to via 2 flat cables.

The ignition key (SW1) is inserted in relevant slot on the steering column,

The display electronic board (EB2) sends all the input signals from the Dashboard instrument electronic board (EB4) to the function electronic board (EB1) using 2-wire 2-way serial communications protocol.

The system is completed by the on-board battery charger (see the Electrical System chapter) which also uses a proprietary serial protocol to communicate with the function electronic board (EB1), in order to display its operating status (charging phase) to the operator on the LCD display.

## Wiring Diagram

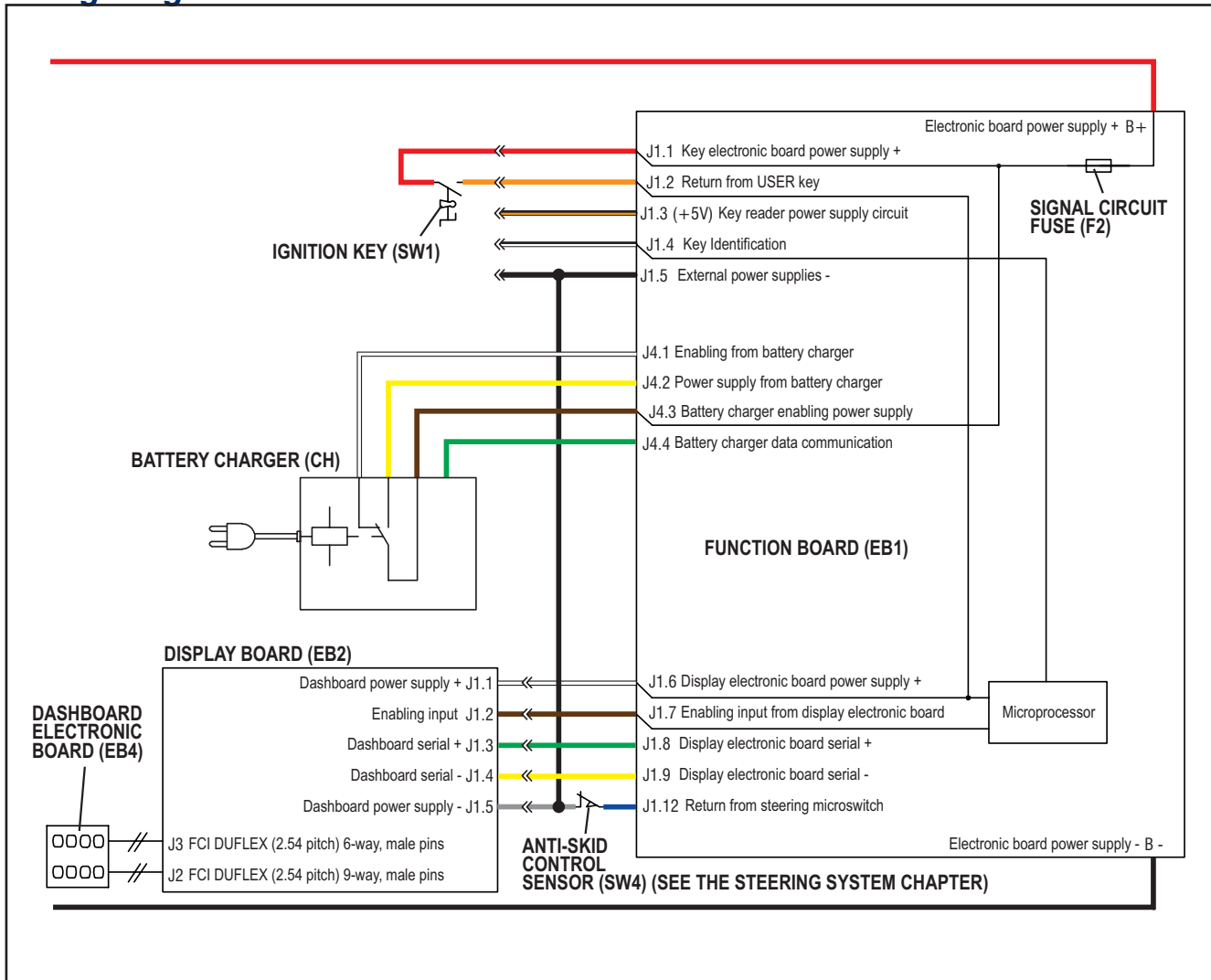


Figure 1

### Component Locations

- Function electronic board (EB1)
- Display electronic board (EB2)
- Dashboard instrument electronic board (EB4)
- Flat cables from (EB2) to (EB4)
- Ignition Key (SW1)

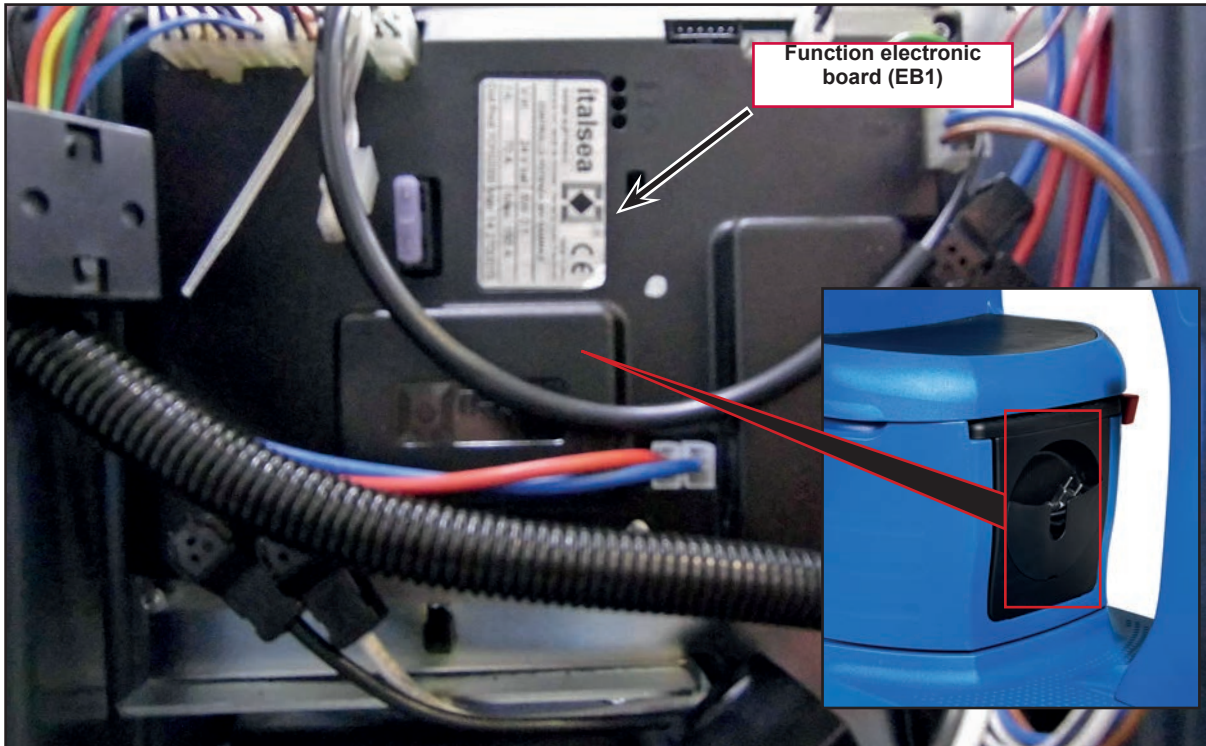


Figure 2



Figure 3

## Troubleshooting

### Function Electronic Board (EB1) Alarm Codes

The function electronic board indicates a series of alarms in case of malfunction of one or more systems, and in case of abnormal conditions detected in the input signals.

The alarms are shown on the display in the following format (Figure 4).



Figure 4

In case the display is malfunctioning, the alarms are also repeated by the yellow and red diagnostic LEDs (Figure 5) on the function electronic board (EB1), as indicated in the following tables.

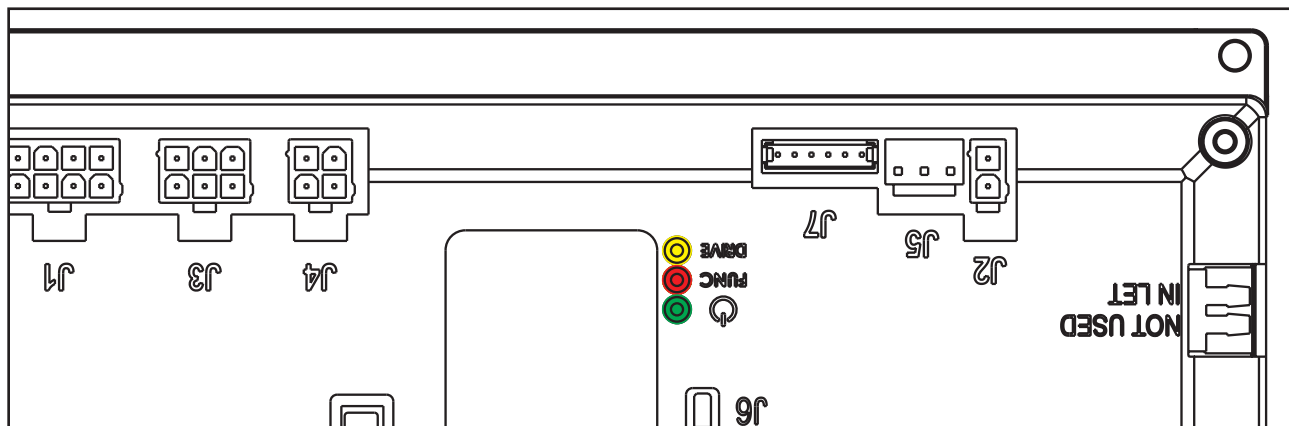


Figure 5

| General alarms   |                |              |              |  |  |
|--|----------------|--------------|--------------|--|--|
| Alarm on function electronic board - FLASHING YELLOW + RED LEDES |                |              |              |  |  |
| Alarm code<br>-----<br>Description                               | No.<br>Flashes | Meaning      | Condition    | Effect                                       | Service Suggestions  |
| <b>G2</b><br>-----<br><b>EEPROM<br/>ERROR</b>                    | 2              | EEPROM error | EEPROM error | Function block<br>+ Default setting<br>reset | If the machine continues to function after G2 has been displayed, this may have been caused by a significant external electromagnetic disturbance.<br>1. Check that the settings and parameters (see page 30) are correct (they may have returned to their defaults). If the error persists, the board must be replaced. |

**Function Electronic Board (EB1) Alarm Codes (Continues)**

| <b>General alarms</b>  |                        |  |   |                 |   |
|--|------------------------|--|---|-----------------|---|
| <b>Alarm on function electronic board - FLASHING YELLOW + RED LEDS</b> |                        |  |   |                 |   |
| <i>Alarm code</i><br>-----<br><i>Description</i>                       | <i>No.<br/>Flashes</i> | <i>Meaning</i>   | <i>Condition</i>  | <i>Effect</i>   | <i>Service Suggestions</i>  |
| <b>G3</b><br>-----<br><b>MAIN FUSE FAILURE</b>                         | 3                      | Blown F1 fuse.   | Blown F1 fuse.<br><br>Broken battery.   | Function block. | F1 is a safety fuse primarily included to prevent a short circuit or serious damage to the electronic board causing currents such as to melt cables and/or cause smoke or fire. If F1 has blown, this is usually indicative of serious damage to the electronic board.<br><br>1. Removing the cover should allow you to understand the extent of the damage, but the solution in any case should be to replace the electronic board.<br><br>2. Try replacing fuse F1 only if there is no clear damage to the electronic board and wiring.<br><br>3. Ensure you tighten the fuse contacts correctly.<br><br>It could happen also if a battery is broken: Check the battery voltage under load. |
| <b>G4</b><br>-----<br><b>BATTERY LOW VOLTAGE</b>                       | 4                      | Undervoltage.  | The battery voltage remains below 18.4V for over 10 seconds (for WET CELL batteries, 19.6V for GEL-AGM batteries).                | Function block. | 1. Check the battery voltage under no-load conditions and under load. Replace the faulty battery/batteries if necessary.<br><br>2. Recharge the batteries by performing a complete charging cycle.  |
| <b>G5</b><br>-----<br><b>BATTERY OVERVOLTAGE</b>                       | 5                      | Excessive battery voltage.   | Battery voltage over 32V.   | Function block. | Check the voltage of the installed batteries and that the terminals are correctly tightened.  |
| <b>G6</b><br>-----<br><b>HARDWARE FAILURE</b>                          | 6                      | Serial communication error with dashboard instrument electronic board. | No signal or error in communications decoding between the function electronic board (EB1) and the display electronic board (EB2). | No block.       | 1. Check the 5 cables from the 6-way dashboard instrument electronic board connector to connector J3 pins 1, 2, 3, 4.<br><br>2. If there is continuity, the dashboard instrument electronic board must be replaced.   |
| <b>G7</b><br>-----<br><b>HARDWARE FAILURE</b>                          | 7                      | General relay fault.   | Relay closes or closed at start-up.   | Function block. | Replace the electronic board.   |

**Function Electronic Board (EB1) Alarm Codes (Continues)**

| <b>Function electronic board alarms</b>                      |  |  |   |  |   |
|--|--|--|---|--|---|
| <b>Alarm on function electronic board - FLASHING RED LED</b> |  |  |   |  |   |
| <i>Alarm code</i><br>-----<br><i>Description</i>             | <i>No.</i><br><i>flashes on</i><br><i>electronic</i><br><i>board</i> | <i>Meaning</i>   | <i>Condition</i>  | <i>Effect</i>                              | <i>Service Suggestions</i>  |
| <b>F2</b><br>-----<br><b>BRUSH MOTOR OVERLOAD</b>            | 2  | BRUSH motor amperometric protection.                     | The voltage drop measured on fuse F1 is greater than the value of the parameter (see page 29) VS1 | Brush electromagnetic switch output block. | Check the amperage of the brush motor. It should remain below the value set in the parameter "VS1" during operation.  |
| <b>F3</b><br>-----<br><b>VACUUM MOTOR OVERLOAD</b>           | 3  | VACUUM SYSTEM amperometric protection.                   | The amperage of the vacuum system motor is greater than 30A for over 10 seconds.                  | Vacuum system block.                       | 1. Check for any debris in the vacuum system motor.<br>2. Check that the motor rotor turns freely.<br>3. Replace the vacuum system motor if necessary.  |
| <b>F4</b><br>-----<br><b>DECK ACTUATOR FAILURE</b>           | 4  | DECK ACTUATOR overcurrent.                               | Current greater than 4A detected for more than 1 second.  | Brush function block.                      | 1. Check that there is no friction on the brush deck linkage; lubricate if necessary.<br>2. Check that the actuator and deck travel is not blocked by mechanical obstructions.<br>3. If the problem persists, replace the actuator. |
| <b>F5</b><br>-----<br><b>SQUEEGEE ACTUATOR FAILURE</b>       | 5  | SQUEEGEE ACTUATOR overcurrent.                           | Current greater than 4A detected for more than 1 second.  | Vacuum function block.                     | 1. Check that there is no friction on the brush deck linkage; lubricate if necessary.<br>2. Check that the actuator and deck travel is not blocked by mechanical obstructions.<br>3. If the problem persists, replace the actuator. |
| <b>F6</b><br>-----<br><b>HARDWARE FAILURE</b>                | 5  | Short circuit on the vacuum or brush motor drive MOSFET. | MOSFET short circuit.   | Function block.                            | 1. Check that there are no short circuits in the motor wiring.<br>2. Replace the electronic board.  |
| <b>F7</b><br>-----<br><b>OVERHEATING</b>                     | 7  | Motor drive section thermal cut-out.                     | The heatsink on the electronic board has reached a temperature of 194 °F (90 °C).                 | Function block.                            | Check the vacuum system and brush motor amperage; also check that the openings of the electrical compartment are not blocked.   |
| <b>F8</b><br>-----<br><b>BRUSH MOTOR FAILURE</b>             | 8  | Brush motor output short circuit.                        | $I > 150A$ for 20μsec.  | Function block.                            | Check for short circuits in the wiring or motor.  |
| <b>F9</b><br>-----<br><b>VACUUM MOTOR FAILURE</b>            | 9  | Vacuum system motor output overcurrent.                  | $I > 150A$ for 20μsec.  | Function block.                            | Check for short circuits in the wiring or motor.  |



**Function Electronic Board (EB1) Alarm Codes (Continues)**

| <b>Drive system alarms</b>                                      |  |  |   |                |  |
|---|--|--|---|----------------|--|
| <b>Alarm on function electronic board - FLASHING YELLOW LED</b> |  |  |   |                |  |
| <i>Alarm code</i><br>-----<br><i>Description</i>                | <i>No. flashes on electronic board</i> | <i>Meaning</i>   | <i>Condition</i>  | <i>Effect</i>  | <i>Service Suggestions</i>   |
| <b>T2</b><br>-----<br><b>DRIVE MOTOR OVERLOAD</b>               | 2                                      | Amperometric protection intervention.                              | Drive system motor amperage greater than the parameter (see page 28) "INOM" for more than the parameter (see page 30) "TMAX". | Drive blocked. | Check the drive system motor amperage (this should be around 6-8A without load and remain below 10/12A during operation).  |
| <b>T3</b><br>-----<br><b>RELEASE THE PEDAL !</b>                | 3                                      | Pedal not in rest position when the electronic board is turned on. | Voltage on J1.2 of EB2 electronic board above the value of "DEADL" parameter.   | Drive blocked. | Check that the pedal moves correctly, lubricating if necessary; check the linkage and potentiometer.   |
| <b>T4</b><br>-----<br><b>PEDAL INPUT FAILURE</b>                | 4                                      | Incorrect voltage measured at the pedal potentiometer input.       | Voltage on J1.2 of electronic board EB2 above 6V.   | Drive blocked. | <ol style="list-style-type: none"> <li>1. Check the connection of the potentiometer to the electronic board.</li> <li>2. Replace the pedal potentiometer.</li> </ol>   |
| <b>T5</b><br>-----<br><b>HARDWARE FAILURE</b>                   | 5                                      | Drive system power section damage                                  | MOSFET short circuit.   | Drive blocked. | <ol style="list-style-type: none"> <li>1. Check that the cables of the gearmotor are not short circuited (try disconnecting the connectors from contacts M1 and M2) and try starting the machine and pressing the pedal again</li> <li>2. If the alarm persists, replace the electronic board</li> </ol>   |
| <b>T6</b><br>-----<br><b>DRIVE MOTOR FAILURE</b>                | 6                                      | Overcurrent (motor D.C.)   | Drive system motor amperage greater than 1.5 times the value of the parameter (see page 28) "IMAX".                           | Drive blocked. | <ol style="list-style-type: none"> <li>1. Check that the gearmotor cables are not short circuited</li> <li>2. Check that the motor of the gearmotor unit is not short circuited (the impedance of the motor should be around 0.6 – 0.8 Ohm)</li> <li>3. If necessary, replace the gearmotor unit motor</li> </ol>  |
| <b>T7</b><br>-----<br><b>OVERHEATING</b>                        | 7                                      | Drive system motor drive section thermal cut-out.                  | The heatsink on the electronic board has reached a temperature of 194 °F (90 °C).   | Drive blocked. | <ol style="list-style-type: none"> <li>1. Check the drive system motor amperage and that the openings of the electrical compartment are not blocked.</li> <li>2. If everything is within normal parameters, this may simply have been caused by extreme working conditions such as: ambient temperature over 86 °F (&gt;30 °C), sloping working sections. Simply leave the system to cool and turn the machine back on.</li> </ol> |
| <b>T8</b><br>-----<br><b>ELETTROBRAKE FAILURE</b>               | 8                                      | Drive system motor electromagnetic brake failure                   | Electromagnetic brake resistance above 1 kΩ.  | Drive blocked. | <ol style="list-style-type: none"> <li>1. Check the electromagnetic brake connection.</li> <li>2. Replace the electromagnetic brake.</li> </ol>  |

All alarms of the drive system operate by cutting the power supply to the gearmotor unit motor until the KEY input is reset (with the exception of alarm T3 which is reset as soon as the input voltage of the paddle potentiometer returns within the values corresponding to "machine stopped"). In case of simultaneous errors, the one with greater priority is shown first (priority order is opposite to the number of flashes).

**Function Electronic Board (EB1) Alarm Codes (Continues)**

| <b>On-board Battery Charger Alarms</b>                |  |  |  |   |
|---|--|--|--|---|
| <i>Alarm code</i><br>-----<br><i>Description</i>      | <i>Meaning</i>   | <i>Condition</i>   | <i>Effect</i>  | <i>Service Suggestions</i>  |
| <b>C1</b><br>-----<br><b>CHARGER COMMUNICATION</b>    | Communication problem between the battery charger and function electronic board. | No signal from battery charger via gate J4.4 for over 3 seconds. | The battery charger is performing the standard recharging cycle for generic GEL/AGM batteries. | Check the wiring between the battery charger and function electronic board.   |
| <b>C2</b><br>-----<br><b>BATTERY OVERVOLTAGE</b>      | Battery overvoltage.   | Battery voltage over 32V.  | Battery charger block.   | 1. Check the connections of the batteries and the voltage of the installed batteries.<br>2. Disconnect and reconnect the battery charger. |
| <b>C4</b><br>-----<br><b>CHARGING TIME I EXPIRED</b>  | Charging phase I expired.  | Battery excessively discharged or at end of life cycle.          | Battery charger block.   | If the problem persists, replace the batteries.   |
| <b>C5</b><br>-----<br><b>CHARGING TIME II EXPIRED</b> | Charging phase II expired.   | Battery excessively discharged or at end of life cycle.          | Battery charger block.   | If the problem persists, replace the batteries.   |
| <b>C6</b><br>-----<br><b>CHARGER FAULT</b>            | Battery charger internal short circuit.  | Battery charger internal short circuit.                          | Battery charger block.   | Replace the battery charger.  |

## Super User Screen

The alarms activated during normal machine operation are stored and can be read in the corresponding log (Alarm Log Screen).

## Alarm Log Screen

The alarms log screen (F, Figure 6) function allows you to check any alarms stored on the machine.

1. Turn the ignition key to “I” holding down both the horn button (A) together with the adjustment percentage detergent button (B).
2. Press hold 1 second the reverse button (C) to switch to the screen menu (D).
3. Press the vacuum system button (E) to access the alarm log screen (F).
4. To return to the menu screen (D) repeatedly press the One-Touch button (G).



Figure 6

Each alarm (See table of alarms in the Function Electronic Board Alarm Codes paragraph) is stored along with the working hour (machine operating time counter) at which it occurred and all alarms are recorded in the order in which they occurred, from the most recent to the oldest.


The memory holds up to 20 alarm records, after which the oldest are overwritten when new alarms occur.

### Alarm Log Screen (continues)

Improper uses of the batteries or battery charger are also recorded, as in the following table:

| On-board Battery Charger Alarms   |  |  |  |
|---|--|--|--|
| Alarm code<br>-----<br>Description  | Meaning  | Condition  | Effect   |
| <b>GB-N</b><br>-----<br><b>CONTINUOUS<br/>LOW BATTERY<br/>VOLTAGE</b>     | Time of continuous use with discharged batteries | "N" is the number of hours from key on to off when the battery level is below 18.4V for WET CELL (19.6 for AGM) batteries. This event is not recorded if the usage time is below 10 minutes. | Incorrect use by customer. Risk of reduced battery life. |
| <b>GC</b><br>-----<br><b>CHARGER<br/>DISCONN<br/>BEFORE END<br/>CYCLE</b> | Charging cycle interrupted before completion     | Disconnection of battery charger before stage IV = battery symbol with 3 segments lit steadily.  | Incorrect use by customer. Risk of reduced battery life. |
| <b>GD-N</b><br>-----<br><b>CHARGING<br/>TIME LESS<br/>THAN 4 HOURS</b>    | Charging phase duration                          | N = Number of hours from battery charger connection to completion of PHASE II (red LED on) if < 4  | Incorrect use by customer. Risk of reduced battery life. |

Press the One-Touch button  to skip to the next Alarm logged.

Press and keep pressed for 3 seconds the vacuum button  to reset the memory log.

## Setting Screen

The machine function parameters screen (C, Figure 7) allows you to customise some parameters described in the following table of modifiable parameters.

1. Turn the ignition key to “I” holding down both the horn button (A) together with the adjustment percentage detergent button (B).
2. Press the One-Touch button (D) to increase the value of the current parameter.
3. Press the vacuum system button (E) to decrease the value of the current parameter.
4. To move to the next parameter press the reverse button (F), or hold it for 1 second to return to the screen menu (G).

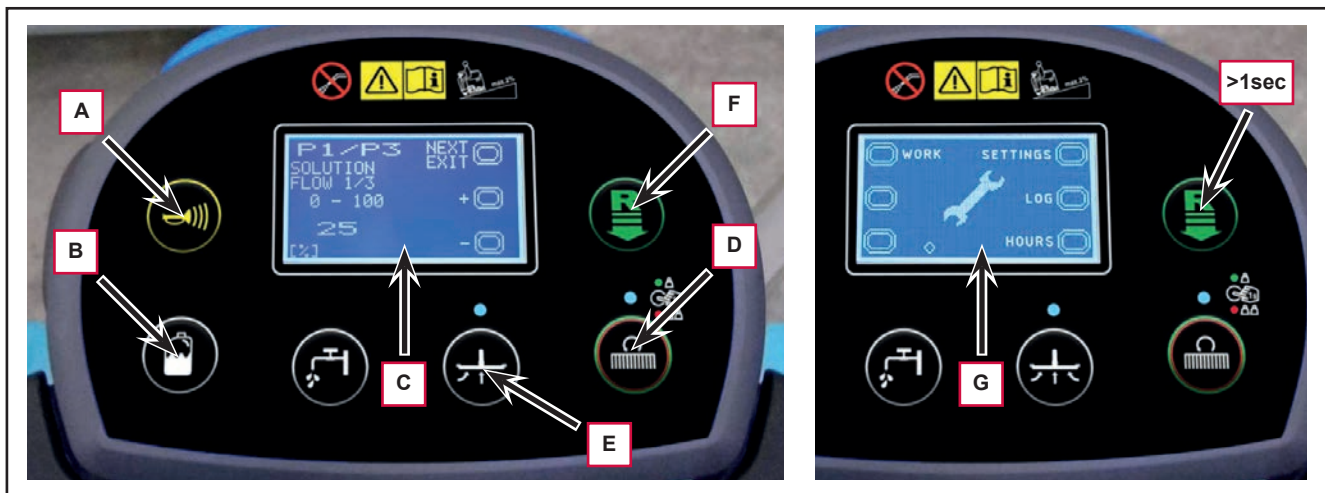





Figure 7

| MODIFIABLE PARAMETERS |  |              |                 |            |
|-----------------------|--|--------------|-----------------|------------|
| Code                  | Description  | Min. Value   | Factory Setting | Max. Value |
| <b>P1/P3</b>          | Level 1 solution flow rate in relation to level 3 (see “System for Flow Rate Regulation as Function of Speed” paragraph) | 0 %          | <b>25 %</b>     | 100 %      |
| <b>P2/P3</b>          | Level 2 solution flow rate in relation to level 3 (see “System for Flow Rate Regulation as Function of Speed” paragraph) | 0 %          | <b>50 %</b>     | 100 %      |
| <b>P3</b>             | Level 3 solution flow rate   | 1.0 cl/m     | <b>3.0 cl/m</b> | 5.0 cl/m   |
| <b>P4</b>             | Level 4 enabling (2.8 l/min regardless of speed)   | OFF          | <b>OFF</b>      | ON         |
| <b>XPRES</b>          | Brush deck extra pressure enabling   | OFF          | <b>ON</b>       | ON         |
| <b>FVMAX</b>          | Maximum forward speed  | 10 %         | <b>100 %</b>    | 100 %      |
| <b>RVMAX</b>          | Maximum reverse speed  | 10 %         | <b>40 %</b>     | 50 %       |
| <b>WSMIN</b>          | Minimum working speed  | 10 %         | <b>25 %</b>     | 100 %      |
| <b>WSMAX</b>          | Maximum working speed  | 10 %         | <b>100 %</b>    | 100 %      |
| <b>BRK</b>            | Electromagnetic brake activation delay   | 0 sec.       | <b>3 sec.</b>   | 5 sec.     |
| <b>BAT</b>            | Installed battery type   | 0            | <b>1</b>        | 5          |
| <b>TOFF</b>           | Automatic shut-off time  | 0 (disabled) | <b>300 sec.</b> | 600 sec.   |
| <b>BRGH</b>           | Display contrast   | 5            | <b>15</b>       | 50         |
| <b>RPM (*)</b>        | Reduced brush rpm activation threshold   | 5            | <b>9</b>        | 20         |
| <b>RESET (**)</b>     | Restore factory settings for all parameters  | OFF          | <b>OFF</b>      | ON         |

(\*) Increase the value of this parameter to reduce the brush motor speed in a wider range of applications and vice versa

(\*\*) The RESET function acts only on “MODIFIABLE PARAMETERS” and not on “HIDDEN PARAMETERS”.

## Setting Screen (Continues)

The following parameters are displayed only when, on reaching the last RESET parameter, the reverse button  is pressed together with the detergent percentage adjustment button  and the solution flow adjustment button .

Otherwise at the reverse button  pressed, the system will return to the first parameter P1/P3.

| HIDDEN PARAMETERS |   |            |                 |            |  |
|-------------------|---|------------|-----------------|------------|--|
| Code              | Description                                 | Min. Value | Factory Setting | Max. Value | Meaning  |
| <b>TSERV</b>      | Service advisory timer (hours)              | 0          | <b>0</b>        | 1000       | Set to a value X greater than 0 if you wish the "Service Advisory" icon to be displayed every X hours of machine running time (according to the main operating time counter). To reset the time counter for the icon display countdown (until the next service advisory), press the BURST and vacuum buttons for 10 seconds with the display on the "SERVICE MENU" page. |
| <b>AR</b>         | Maximum acceleration ramp (sec.)            | 0.5        | <b>1.5</b>      | 5          | Increase to obtain a less abrupt response when accelerating, and vice versa.   |
| <b>DR</b>         | Maximum deceleration ramp (sec.)            | 0.5        | <b>0.6</b>      | 3          | Increase to obtain a less abrupt response when decelerating, and vice versa.<br><b>WARNING: increasing this value increases the braking distance.</b>  |
| <b>IR</b>         | Maximum deceleration ramp in reverse (sec.) | 0.5        | <b>0.5</b>      | 1          | Increase to obtain a less abrupt response when decelerating doing a reverse gear, and vice versa.<br><b>WARNING: increasing this value increases the braking distance.</b>   |
| <b>AMAX</b>       | Maximum lateral acceleration (g/100)        | 1          | <b>5</b>        | 100        | It is the maximum lateral acceleration allowed to the machine. With this value, the drive system reduces the power to the driving wheel to keep the stability of the machine.<br><b>WARNING: increasing this value increases the risk of machine overturning.</b>  |
| <b>KG</b>         | Lateral acceleration control constant       | 1.0        | <b>1.6</b>      | 2.0        | Engineering parameter connected to AMAX.<br><b>- Do not change.</b>  |
| <b>VS1</b>        | Brush 1 motor protection threshold (A)      | 20         | <b>30</b>       | 50         | This is the maximum current which can be supplied to the disc brush deck.<br><b>WARNING: increasing this value increases the risk of motor overheating.</b>  |
| <b>VS2</b>        | Brush 2 motor protection threshold (A)      | 20         | <b>40</b>       | 50         | This is the maximum current which can be supplied to the cylindrical brush deck (not used).<br><b>WARNING: increasing this value increases the risk of motor overheating.</b>  |
| <b>DEADL</b>      | Drive pedal bottom dead area (V)            | 0.0        | <b>0.1</b>      | 1.0        | Pedal output voltage when the pedal is released.   |
| <b>DEADH</b>      | Drive pedal top dead area (V)               | 0.0        | <b>0.8</b>      | 1.0        | Pedal output voltage when the pedal is fully pressed.  |
| <b>INOM</b>       | Drive system rated current (A)              | 10         | <b>22</b>       | 25         | This is the maximum continuous current which can be supplied to the driving wheel unit.<br><b>WARNING: increasing this value increases the risk of motor overheating.</b>  |
| <b>IMAX</b>       | Drive system maximum current (A)            | 10         | <b>60</b>       | 70         | This is the maximum instantaneous current which can be supplied to the driving wheel unit.<br><b>WARNING: increasing this value increases the risk of motor overheating.</b>   |
| <b>TMAX</b>       | Protection trip time for IMAX (sec.)        | 0          | <b>10</b>       | 60         | This is the reaction time of the driving wheel unit protection device when overloaded: this parameter is used in conjunction with IMAX to obtain the most appropriate response curve for the overload protection motor actuation system.<br><b>WARNING: increasing this value increases the risk of motor overheating.</b>   |

## Hours Screen

1. Turn the ignition key to “I” holding down both the horn button (A, Figure 8) together with the adjustment percentage detergent button (B).
2. Press hold 1 second the reverse button (C) to switch to the screen menu (D).
3. Press the horn button (A) to access the operating time counter screen (E).

The operating time counter screen (E) function allows you to check the total accumulated hours of work for each machine subsystem:

- (F) TOTAL counter (machine running time)
- (G) DRIVE counter (drive system usage time)
- (H) BRUSH counter (brush rotation system usage time)
- (I) VACUUM counter (vacuum system usage time)

4. To return to the screen menu (D) press the One-Touch button (J).

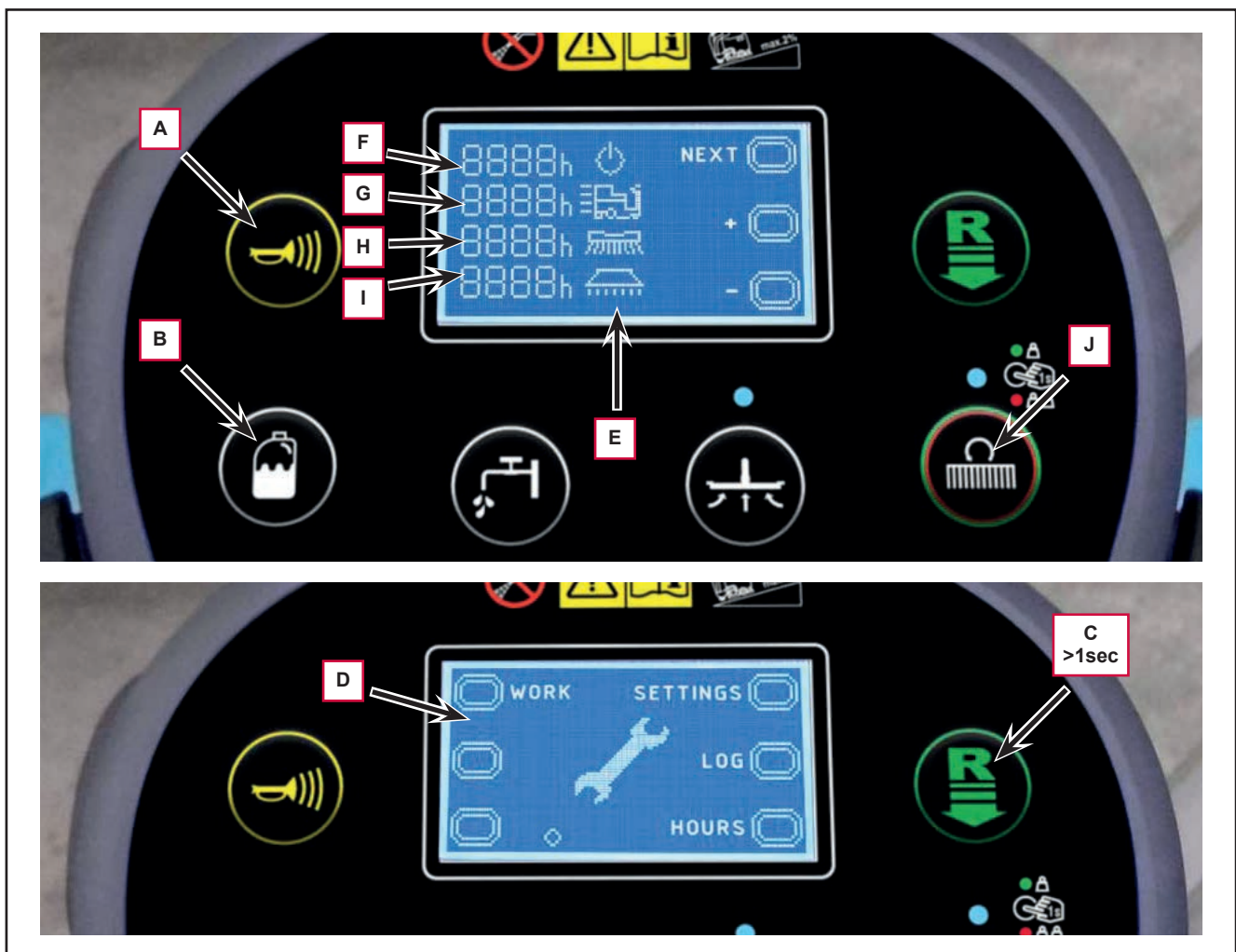


Figure 8

## System for Flow Rate Adjustment as Function of Speed

Solution flow levels 1, 2 and 3 regulate the flow of solution on the basis of the machine speed so as to keep the quantity of solution dispensed per square metre of floor treated constant.

The reference flow level is level 3: based on the setting of the corresponding parameter P3, the opening time of the solenoid valve (and of the detergent pump when fitted) is regulated so that the quantity of solution in centiliters per metre travelled by the machine is constant and equal to the value set in the parameter.

For example, for P3 = 3.0, the machine will dispense 3 centiliters of solution per metre travelled, which equates (for the standard deck width of 530mm) to 5.7 centiliters per square metre of floor treated.

Levels 1 and 2 are defined via the corresponding parameters P1 and P2 as a % of level 3. For example, for P1 = 25 and P2 = 50, P1 and P2 are respectively  $\frac{1}{4}$  (25 %) and  $\frac{1}{2}$  (50 %) of the reference flow rate P3.

The default values (the same as in the example above) are summarized in the table, with the corresponding flow rate values in liters per minute, dependent on machine speed, given as a reference.

| Detergent flow (as a function of speed) (standard setting) |         |         |         |
|--|---------|---------|---------|
|  | Level 1 | Level 2 | Level 3 |
| Liters/minute @ 1 km/h                                     | 0.2     | 0.3     | 0.5     |
| Liters/minute @ 3 km/h                                     | 0.4     | 0.8     | 1.5     |
| Liters/minute @ 5 km/h                                     | 0.6     | 1.3     | 2.5     |
| Centiliters per metre cleaned (constant)                   | 0.75    | 1.5     | 3       |
| Centiliters per meter <sup>2</sup> cleaned (Ø530 deck)     | 1.4     | 2.8     | 5.7     |

Level 4 (when enabled) is independent of any parameter and supplies the maximum possible quantity of solution as it keeps the solenoid valve of the supply system constantly open (with the brush rotating).

| Detergent flow rate       |         |
|---------------------------|---------|
|                           | Level 4 |
| Liters/minute - Tank full | 3.5     |
| Liters/minute - Average   | 2.5     |



## Removal and Installation

### Function Electronic Board (EB1) Removal/Replacement

1. Drive the machine on a level floor and remove the operator key.
2. Disconnect the red battery connector by pressing the emergency push-button.
3. Lift the recovery tank assembly and the driver's seat.
4. Remove the 3 screws and remove the upper cover.
5. Remove the 2 screws and remove the function electronic board front cover.
6. Disconnect the following connections (Figure 9):
  - (A) and (B) Electronic board power supply connection (B+) and (B-).
  - (C) and (D) Brush motor connection (BR+) and (BR-).

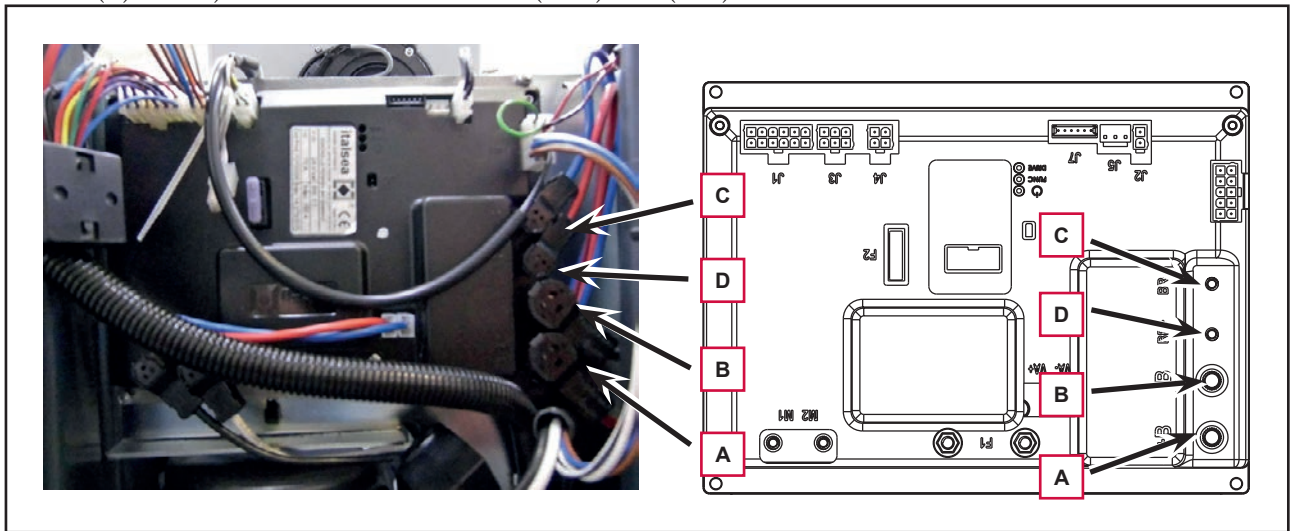


Figure 9

7. Disconnect the following connections (Figure 10):
  - (E) and (F) Drive system motor connection (M1) and (M2).
  - (G) and (H) Vacuum system motor connection (VA+) and (VA-).

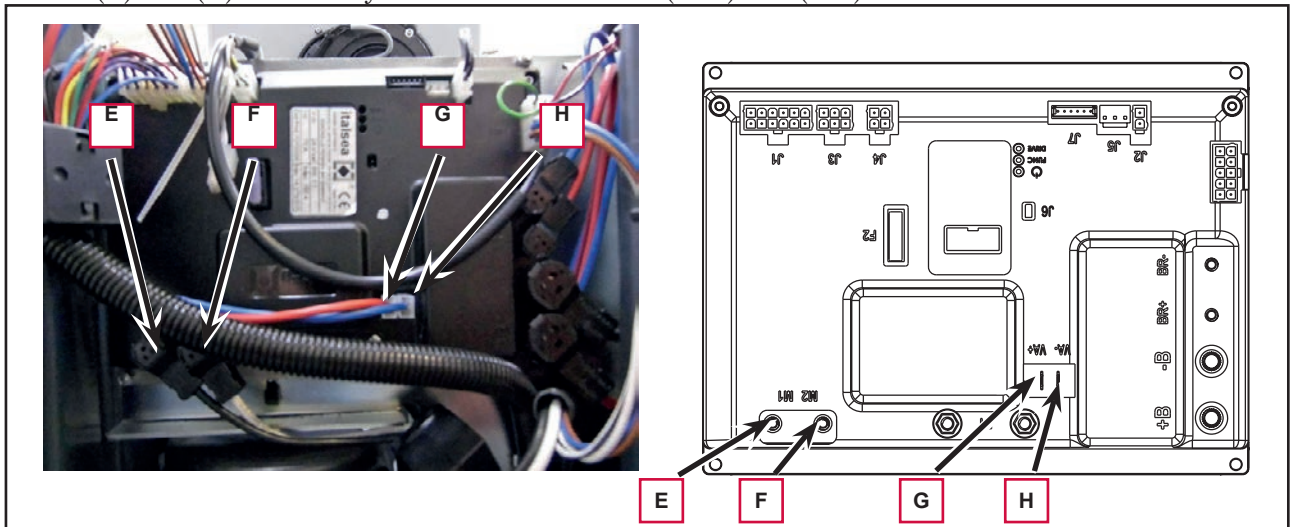


Figure 10

## Function Electronic Board (EB1) Removal/Replacement (Continues)

8. Disconnect the following connections (Figure 11):
- (I) Key, accelerator and steering wheel electronic board connection (J1).
  - (J) Squeegee actuator, beacon light and driver's seat sensor connection (J3).
  - (K) Battery charger connection (J4).
  - (L) Brush deck actuator connection (J2).
  - (M) Accessory connection (J8).

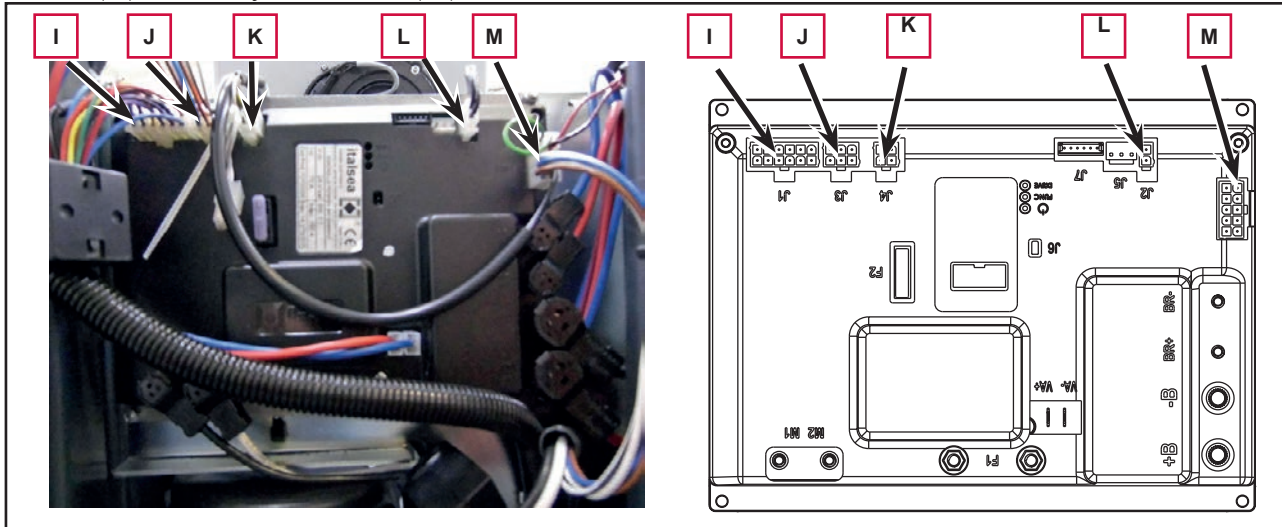


Figure 11

9. Unscrew the 4 retaining screws (N) and carefully remove the function electronic board (Figure 12).

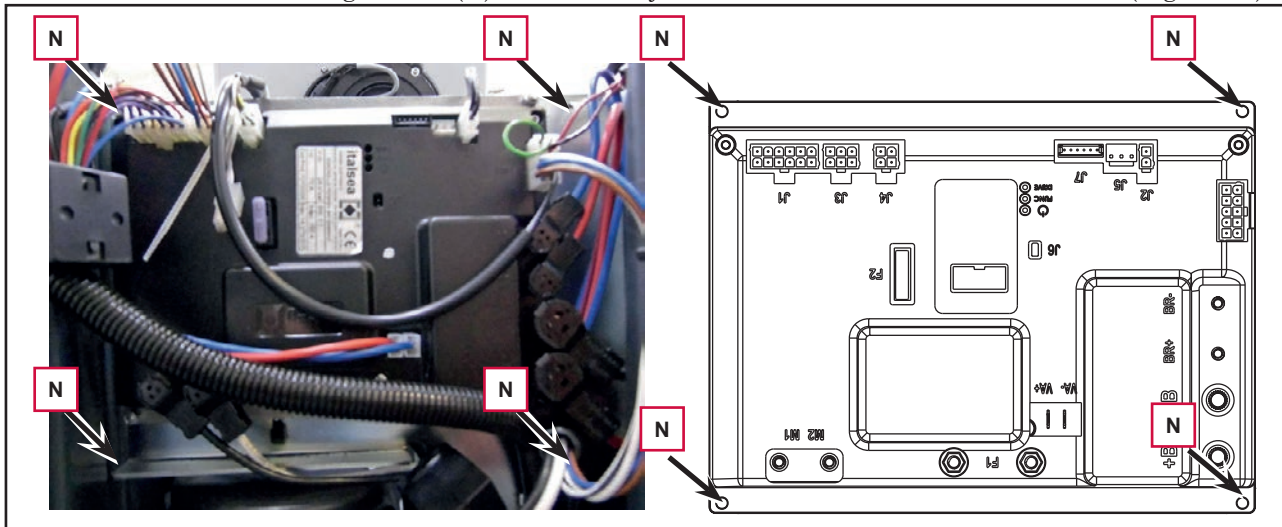


Figure 12

10. Assemble the components in the reverse order of disassembly.

## Display Board (EB2) and Dashboard Instrument Board (EB4) Removal/Replacement

### Display Board (EB2)

1. Drive the machine on a level floor.
2. Remove the operator key and disconnect the red battery connector
3. Remove the steering wheel mounting screws (A, Figure 13).
4. Lift the steering wheel group and disconnect the wiring harness connection (B).
5. At the workbench, remove the 6 screws (C, Figure 14).
6. Lift the cover of the dashboard instrument board (D, Figure 15) and recover the gasket (E).
7. Remove the screws (F) and remove the display electronic board (G).
8. Disconnect the connection (H, Figure 16).
9. Disconnect the flat connections (I) and (J) from the display electronic board (EB2).

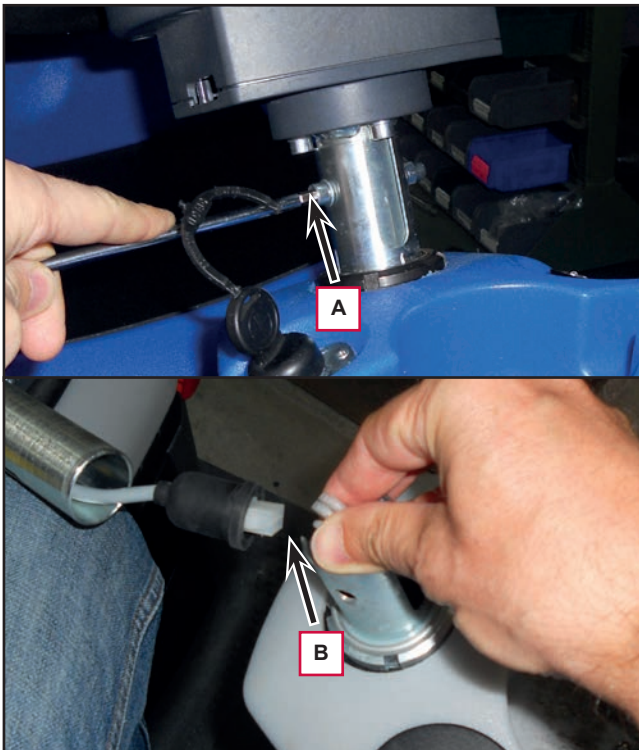


Figura 13



Figura 14

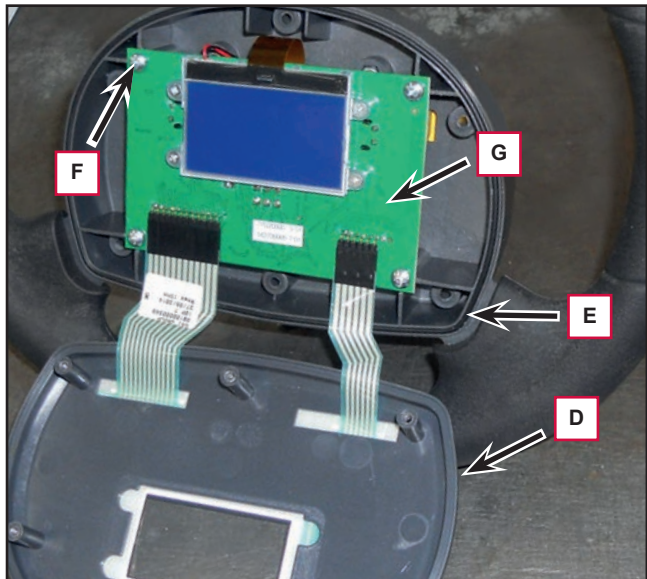


Figura 15

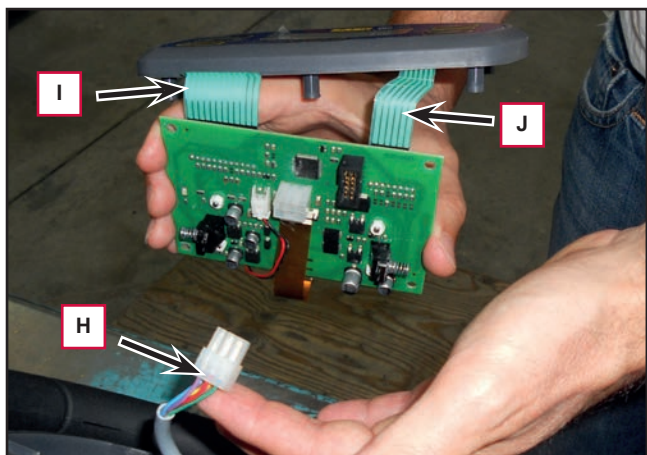


Figura 16

## Display Board (EB2) and Dashboard Instrument Board (EB4) Removal/Replacement (Continues)

### Dashboard Instrument Board (EB4)

10. Perform points 1 to 6 for removal of the display electronic board (EB2).
11. Disconnect the flat connections (K, Figure 17) and (L) from the display electronic board (EB2).
12. Carefully lift the dashboard instrument electronic board (M, Figure 18) and remove it from the cover (N).

### Assembly

13. Assemble the components in the reverse order of disassembly and note the following:
  - Install the display electronic board (EB2) and check the proper operation and function.
  - By carefully, install the dashboard electronic board (EB4) on the cover, paying attention to the routing of the flat connections in the cover slots.

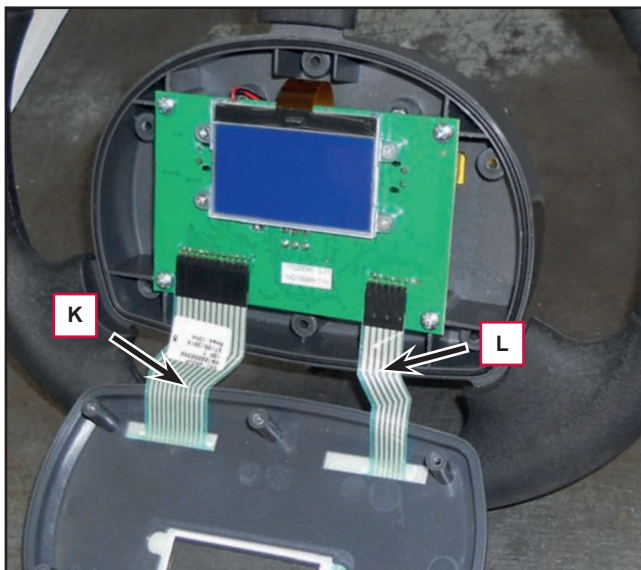


Figura 17

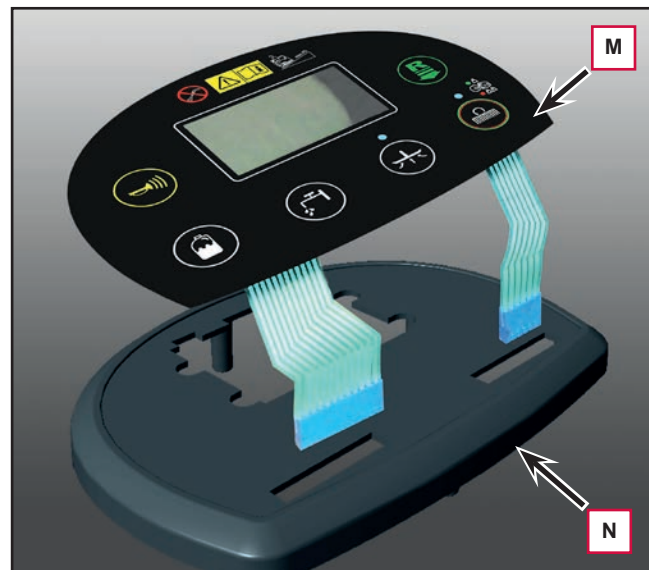
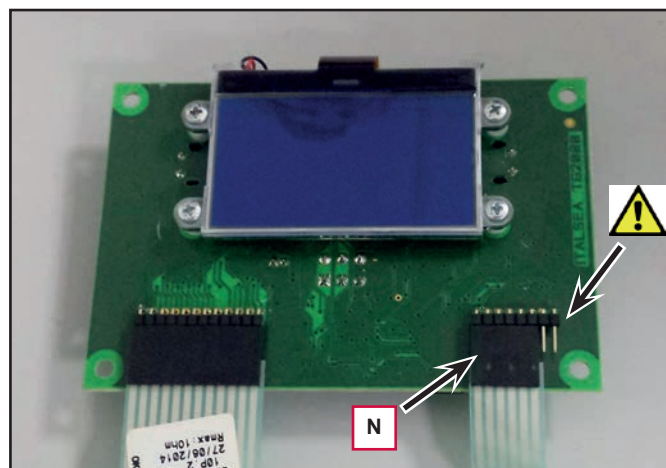


Figura 18



**Warning!** The first batch of Display electronic board (EB2) are equipped with an 8-way male pins on the right side connection (N) instead of a 6-way male pins. Pay attention and mount the connector leaving in sight 2 male pins on the right side as show in the figure:



## Specifications

### Function Electronic Board (EB1) Connectors

(Figure 19) Power connections (Ø6mm male RADSOK terminals - AMPHENOL SK 200800532 101 or equivalent)

| Ref.      | Description                     | Electronic board in/out | V ref. | I max. | Connected to |
|-----------|---------------------------------|-------------------------|--------|--------|--------------|
| <b>B+</b> | Electronic board power supply + | in                      | 24V    | 125A   | BAT+         |
| <b>B-</b> | Electronic board power supply - | in                      | 24V    | 125A   | BAT-         |

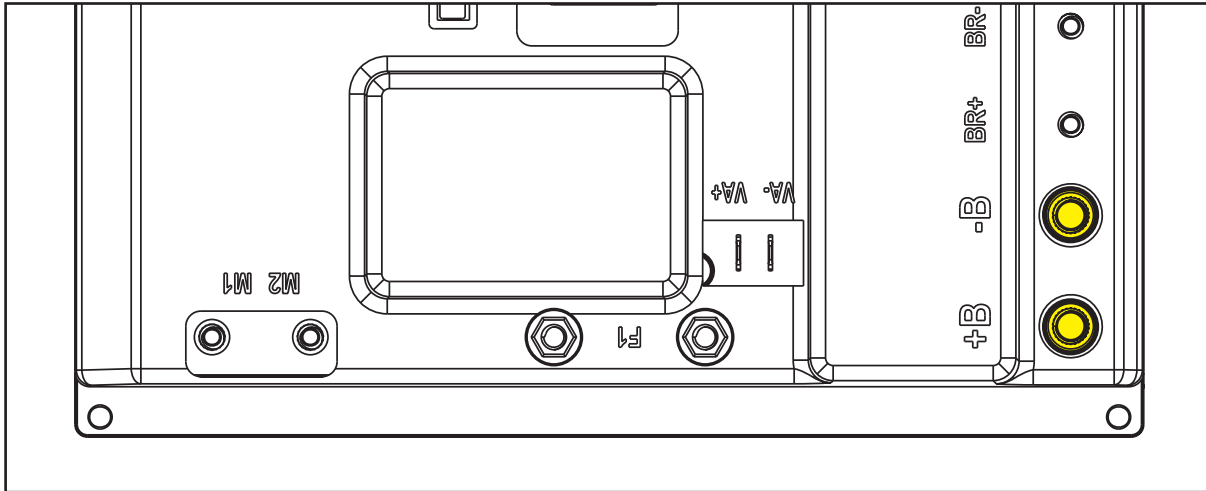


Figure 19

(Figure 20) Drive connections (Ø3.6mm male RADSOK terminals - AMPHENOL P/N N01 036 6501 001 or equivalent)

| Ref.       | Description   | Electronic board in/out | V ref. | I max. | Connected to |
|------------|---------------|-------------------------|--------|--------|--------------|
| <b>BR+</b> | Brush motor + | out                     | 24V    | 50A    | M1+          |
| <b>BR-</b> | Brush motor - | out                     | 24V    | 50A    | M1-          |

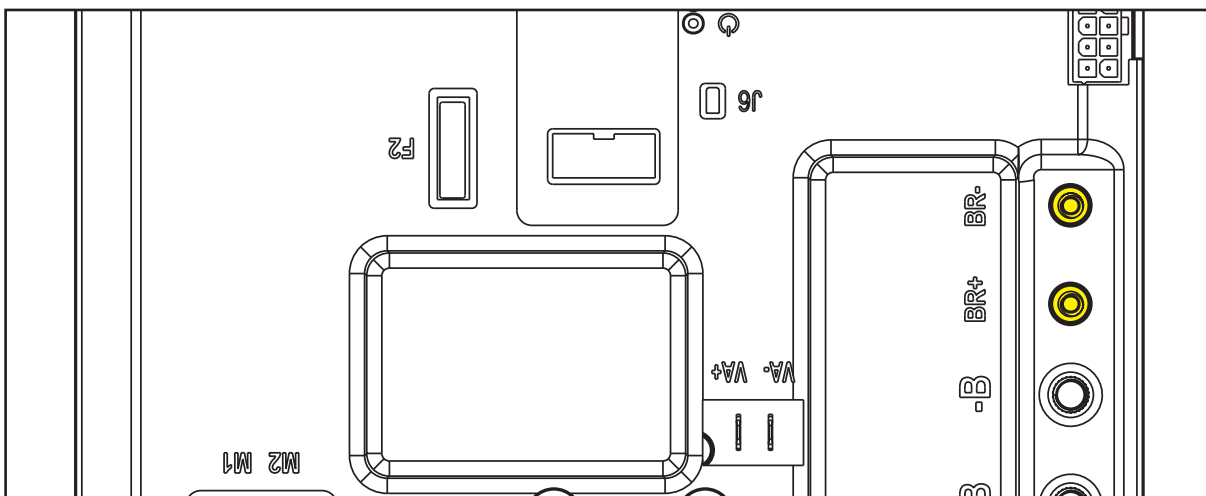


Figure 20

**Function Electronic Board (EB1) Connectors (Continues)**

| (Figure 21) Drive connections (Ø3.6mm male RADSOK terminals - AMPHENOL P/N N01 036 6501 001 or equivalent) |                      |                         |        |        |              |
|--|----------------------|-------------------------|--------|--------|--------------|
| Ref.   | Description          | Electronic board in/out | V ref. | I max. | Connected to |
| <b>M1</b>  | Drive system motor + | out                     | 0-24V  | 70A    | M3+          |
| <b>M2</b>  | Drive system motor - | out                     | 0-24V  | 70A    | M3-          |

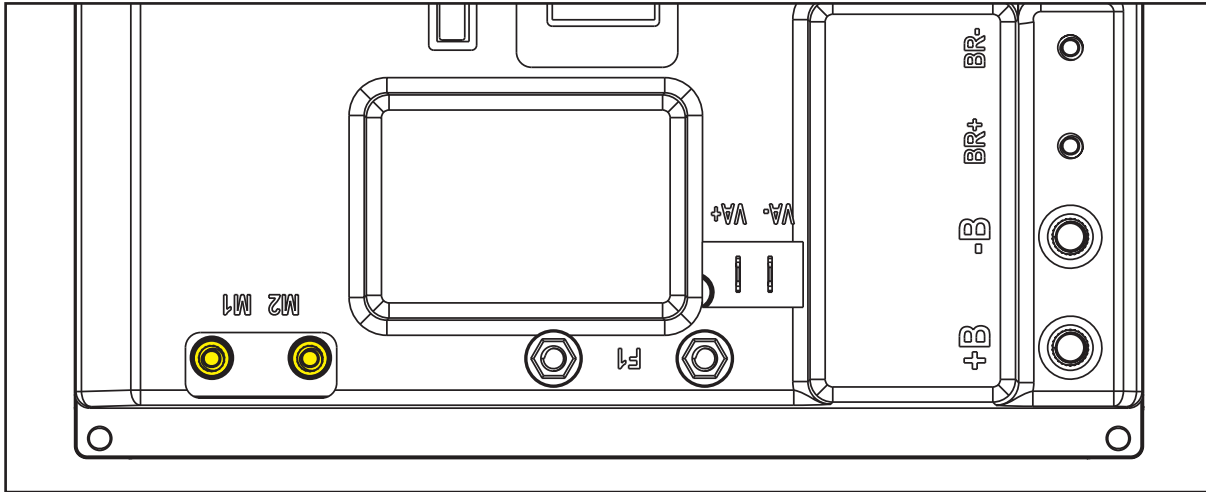


Figure 21

| (Figure 22) Vacuum connections (2-way male parallel faston connectors, 6.3x0.8 – spacing 6.5mm) |                              |                         |        |        |              |
|---|------------------------------|-------------------------|--------|--------|--------------|
| Ref.  | Description                  | Electronic board in/out | V ref. | I max. | Connected to |
| <b>VA+</b>  | Vacuum system power supply + | out                     | 16-24V | 30A    | M2+          |
| <b>VA-</b>  | Vacuum system power supply - | out                     | 0V     | 30A    | M2-          |

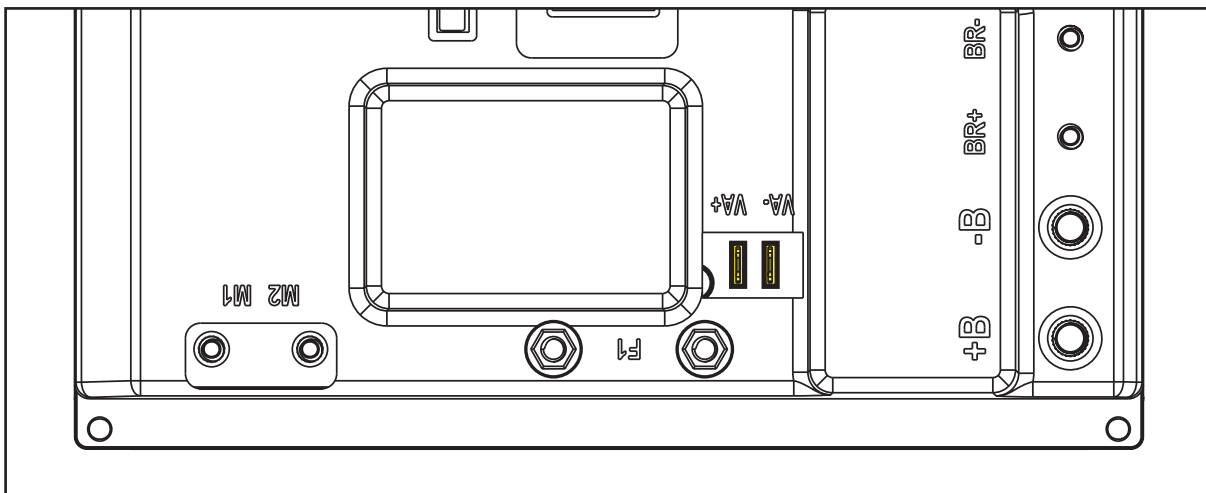


Figure 22

### Function Electronic Board (EB1) Connectors (Continues)

| (Figure 23) J1: MOLEX MINIFIT type, 12-ways vertical |  |                         |        |        |              |
|--|--|-------------------------|--------|--------|--------------|
| PIN  | Description                                  | Electronic board in/out | V ref. | I max. | Connected to |
| 1  | Key electronic board power supply +          | out                     | 24V    | 3A     | SW1          |
| 2  | Return from USER key                         | in                      | 24V    | 3A     | SW1          |
| 3  | Key reader power supply circuit              | out                     | 12V    | <1A    | -            |
| 4  | Key Identification                           | in                      | 0-5V   | <1A    | -            |
| 5  | External power supplies -                    | out                     | 0V     | <1A    | -            |
| 6  | Display electronic board power supply +      | out                     | 24V    | 3A     | EB2.1        |
| 7  | Enabling input from display electronic board | in                      | 24V    | 3A     | EB2.2        |
| 8  | Display electronic board serial +            | in/out                  | 5V     | <1A    | EB2.3        |
| 9  | Display electronic board serial -            | in/out                  | 0V     | <1A    | EB2.4        |
| 10   | Pedal power supply +                         | out                     | 24V    | <1A    | PED.1        |
| 11   | Return from pedal                            | in                      | 0-5V   | <1A    | PED.2        |
| 12   | Return from steering microswitch             | in                      | 0V     | <1A    | SW4          |

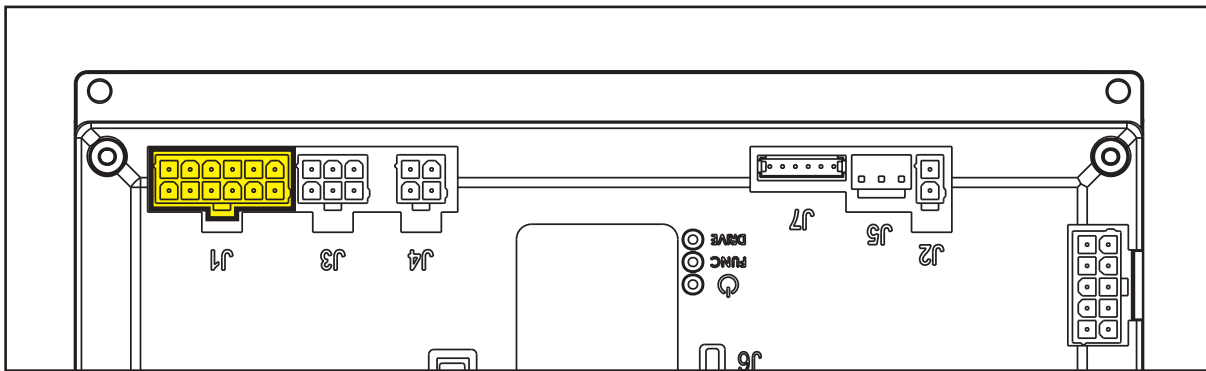


Figure 23

| (Figure 24) J2: MOLEX MINIFIT type, 2-ways vertical |                                |                         |        |        |              |
|---|--------------------------------|-------------------------|--------|--------|--------------|
| PIN   | Description                    | Electronic board in/out | V ref. | I max. | Connected to |
| 1   | Deck actuator power supply +/- | out                     | 0/24V  | 8A     | M5           |
| 2   | Deck actuator power supply -/+ | out                     | 0/24V  | 8A     | M5           |

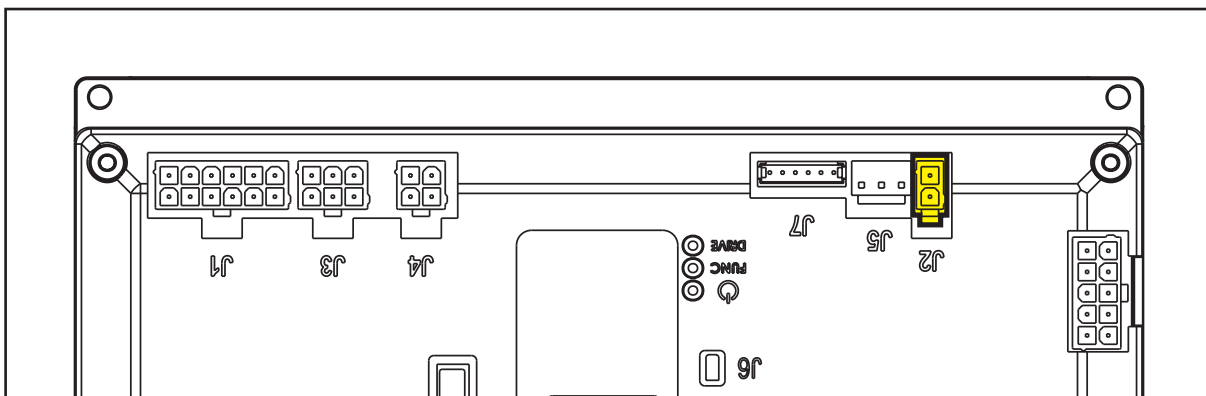


Figure 24

**Function Electronic Board (EB1) Connectors (Continues)**

**(Figure 25) J3: MOLEX MINIFIT type, 6-ways vertical**

| PIN | Description                            | Electronic board in/out | V ref. | I max. | Connected to |
|-----|--|-------------------------|--------|--------|--------------|
| 1   | Squeegee actuator power supply +/-     | out                     | 0/24V  | 8A     | M6           |
| 2   | Driver's seat microswitch power supply | out                     | 0V     | <1A    | SW3          |
| 3   | Auxiliary power supply -               | out                     | 0V     | 1A     | BE1          |
| 4   | Squeegee actuator power supply -/+     | out                     | 0/24V  | 8A     | M6           |
| 5   | Return from driver's seat microswitch  | In                      | 0V     | <1A    | SW3          |
| 6   | Auxiliary power supply +               | out                     | 24V    | 1A     | BE1          |

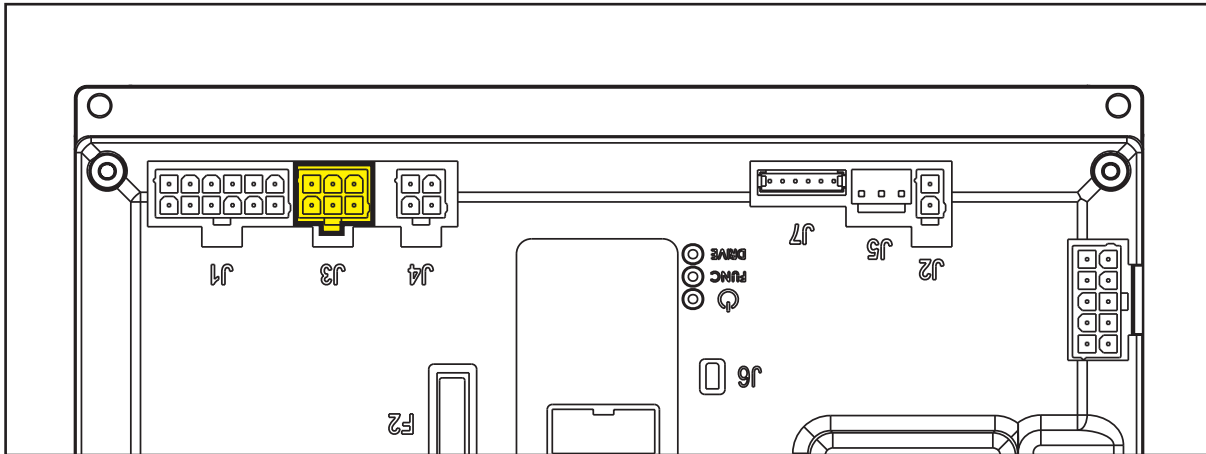


Figure 25

**(Figure 26) J4: MOLEX MINIFIT type, 4-ways vertical**

| PIN | Description                           | Electronic board in/out | V ref. | I max. | Connected to |
|-----|---------------------------------------|-------------------------|--------|--------|--------------|
| 1   | Enabling from battery charger         | in                      | 24V    | <1A    | CH.1         |
| 2   | Power supply from battery charger     | in                      | 24V    | <1A    | CH.2         |
| 3   | Battery charger enabling power supply | out                     | 24V    | <1A    | CH.3         |
| 4   | Battery charger data communication    | in/out                  | 5V     | <1A    | CH.4         |

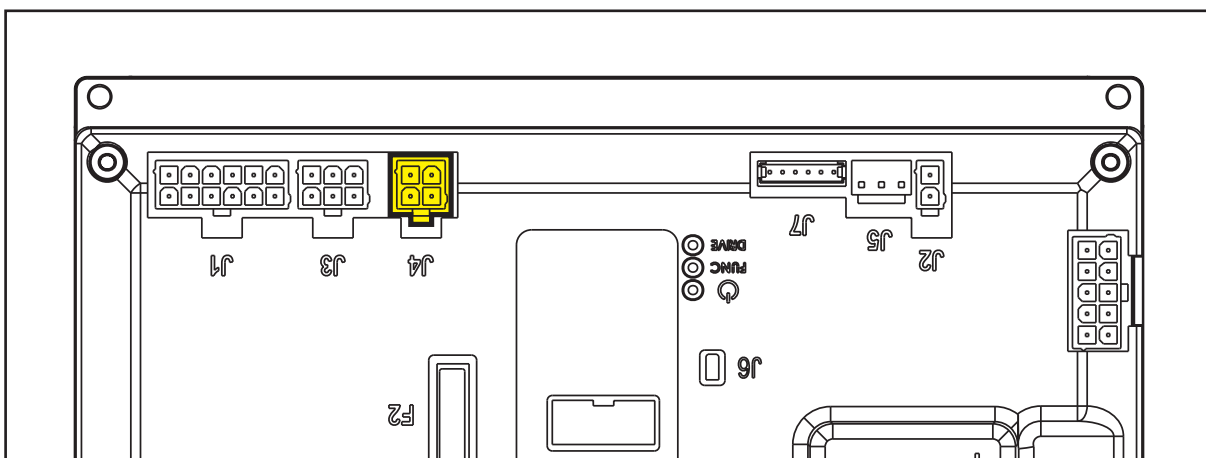


Figure 26



### Function Electronic Board (EB1) Connectors (Continues)

| (Figure 27) J5: JST VHR-3N type, 3-way vertical |                                       |                         |        |        |              |
|---|---------------------------------------|-------------------------|--------|--------|--------------|
| PIN   | Description                           | Electronic board in/out | V ref. | I max. | Connected to |
| 1   | Power supply for water level sensor + | out                     | 24V    | <1A    | S1.1         |
| 2   | Water level sensor return             | in                      | 0V     | <1A    | S1.2         |
| 3   | Power supply for water level sensor - | out                     | 0V     | <1A    | S1.3         |

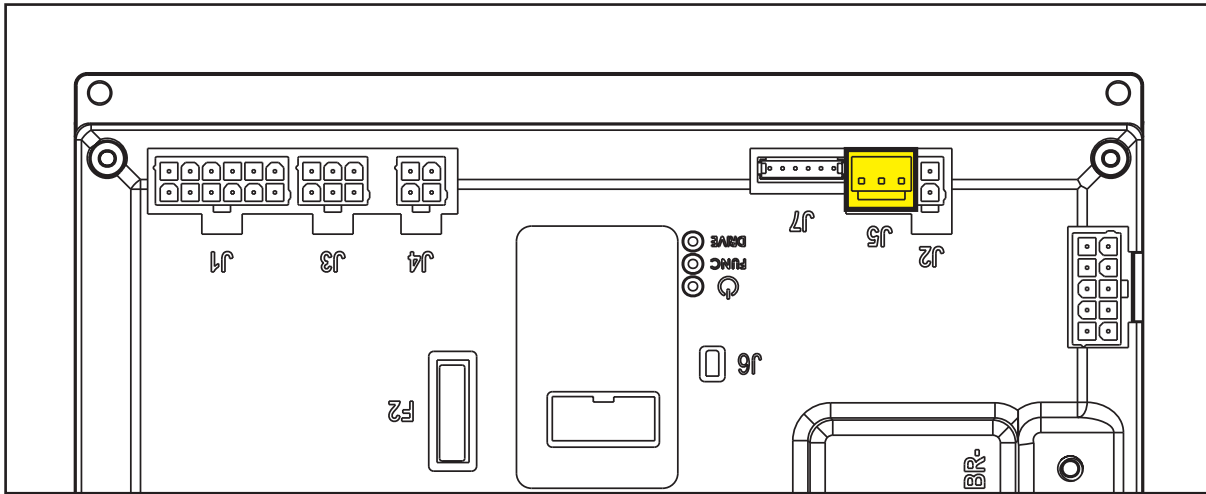


Figure 27

(Figure 28) J6: JUMPER, 2-ways vertical

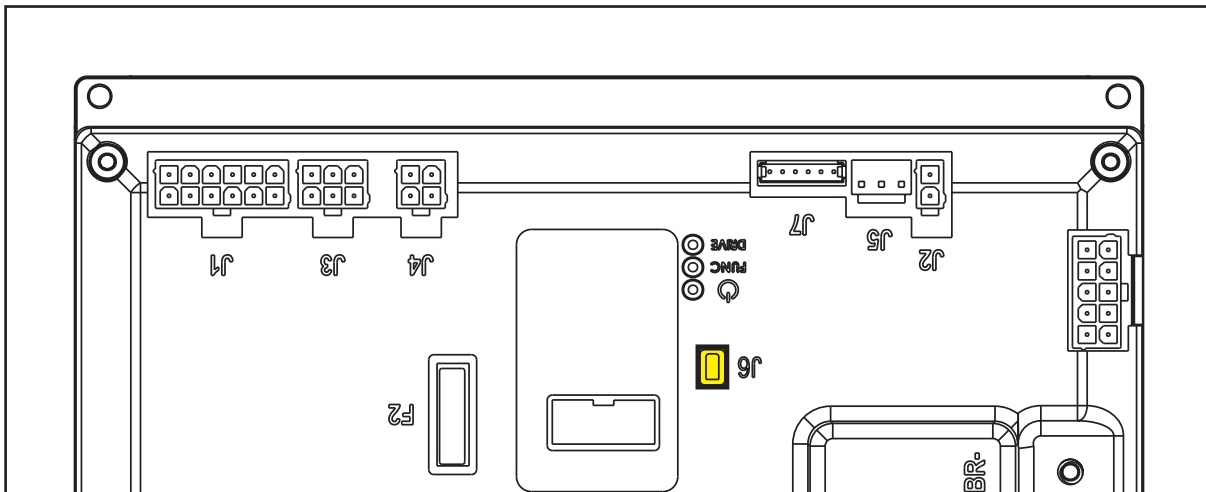


Figure 28

### Function Electronic Board (EB1) Connectors (Continues)

**(Figure 29) J7: TYCO MODU II type, 6-ways vertical**

| PIN | Description                   | Electronic board in/out | V ref.     | I max. | Connected to |
|-----|-------------------------------|-------------------------|------------|--------|--------------|
| 1   | +24V power supply             | out                     | 24V        | <1A    | TRK.RD       |
| 2   | +5V power supply              | out                     | 5V         | <1A    | -            |
| 3   | iButton input                 | in (out)                | 0V (0-5V)  | <1A    | TRK.YE       |
| 4   | External time counter enabled | (in) out                | 0V (0-24V) | <1A    | TRK.WH       |
| 5   | Power supply -                | out                     | 0V         | <1A    | TRK.BU       |
| 6   | Machine on signal             | out                     | 24V        | <1A    | TRK.BN       |

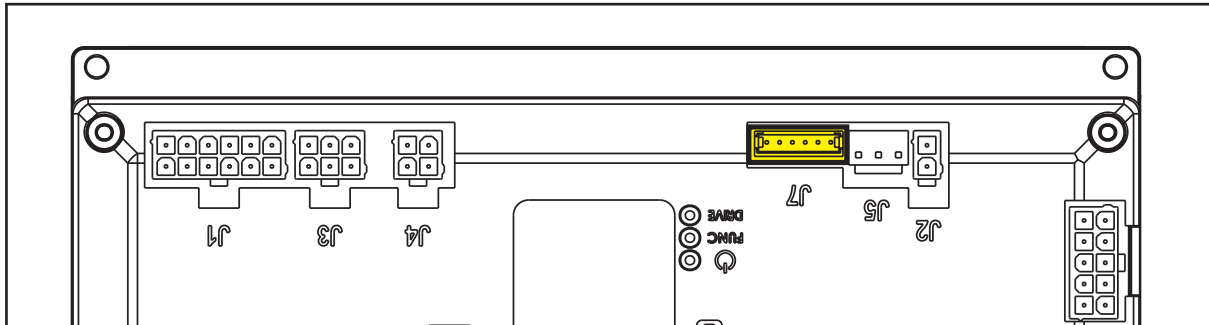


Figure 29

**(Figure 30) J8: TYMOLEX MINIFIT type, 10-ways vertical**

| PIN | Description                        | Electronic board in/out | V ref. | I max. | Connected to |
|-----|------------------------------------|-------------------------|--------|--------|--------------|
| 1   | Solenoid valve power supply -      | out                     | 0V     | 1A     | EV1          |
| 2   | Detergent pump power supply -      | out                     | 0V     | <1A    | M4           |
| 3   | Electromagnetic brake output       | out                     | 0V     | 1A     | BRK          |
| 4   | Opt power supply -                 | out                     | 0V     | 1A     | USB -        |
| 5   | DECK configurator return           | in                      | 0V     | <1A    | J4.10        |
| 6   | Solenoid valve power supply +      | out                     | 24V    | 1A     | EV1          |
| 7   | Detergent pump power supply +      | out                     | 24V    | <1A    | M4           |
| 8   | Electromagnetic brake output +     | out                     | 24V    | 1A     | BRK          |
| 9   | Opt power supply +                 | out                     | 24V    | 1A     | USB +        |
| 10  | Power supply for DECK configurator | out                     | 0V     | <1A    | J4.4         |

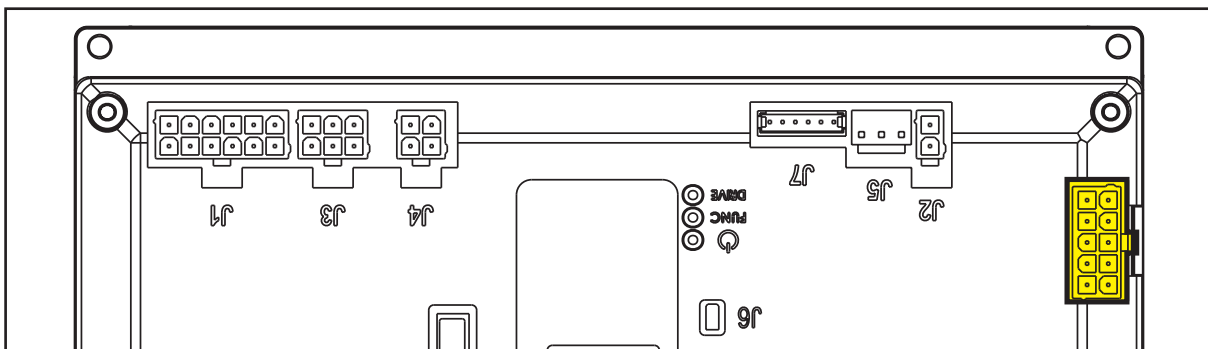


Figure 30

### Display Electronic Board (EB2) Connectors

**(Figure 31) J1: MOLEX MINIFIT type, 6-ways vertical**

| Ref. | Description                       | Electronic board in/out | V ref. | I max. | Connected to |
|------|-----------------------------------|-------------------------|--------|--------|--------------|
| 1    | Power supply +                    | in                      | 24V    | 3A     | CFG2.J1.6    |
| 2    | Machine startup enabling          | out                     | 24V    | 3A     | CFG2.J1.7    |
| 3    | Display electronic board serial + | in/out                  | 5V     | <1A    | CFG2.J1.8    |
| 4    | Display electronic board serial - | in/out                  | 0V     | <1A    | CFG2.J1.9    |
| 5    | Power supply -                    | in                      | 0V     | <1A    | CFG2.J1.5    |
| 6    | Power supply repetition -         | out                     | 0V     | <1A    | -            |

**(Figure 31) J2: FCI DUFLEX (2.54 pitch) 9-way, male pins**

| Ref. | Description                  | Electronic board in/out | V ref. | I max. |  |
|------|------------------------------|-------------------------|--------|--------|--|
| 1    | Power supply - common        | out                     | 0V     | <1A    |  |
| 2    | HORN button (P3)             | in                      | 0V     | <1A    |  |
| 3    | EDS button (P2)              | in                      | 0V     | <1A    |  |
| 4    | DETERGENT MIX button (P1)    | in                      | 0V     | <1A    |  |
| 5    | BRUSH / EXTRAPR. button (P4) | in                      | 0V     | <1A    |  |
| 6    | VACUUM button (P5)           | in                      | 0V     | <1A    |  |
| 7    | BRUSH RELEASE button (P6)    | in                      | 0V     | <1A    |  |
| 8    | ON/OFF button (P0)           | in                      | 0V     | <1A    |  |
| 9    | REVERSE GEAR button (P7)     | in                      | 0V     | <1A    |  |
| 10   | INCREASE SPEED button (P8)   | in                      | 0V     | <1A    |  |
| 11   | DECREASE SPEED button (P9)   | in                      | 0V     | <1A    |  |
| 12   | Dashboard configurator       | in                      | 0V     | <1A    |  |

**(Figure 31) J3: FCI DUFLEX (2.54 pitch) 6-way, male pins**

| Ref. | Description                               | Electronic board in/out | V ref. | I max. |  |
|------|---|-------------------------|--------|--------|--|
| 1    | Power supply – common                     | out                     | 0V     | <1A    |  |
| 2    | BRUSH RELEASE function LED (LD3)          | out                     | 5V     | <1A    |  |
| 3    | VACUUM function LED (LD2)                 | out                     | 5V     | <1A    |  |
| 4    | BRUSH / EXTRAPR funct. LED (red) (LD1R)   | out                     | 5V     | <1A    |  |
| 5    | BRUSH / EXTRAPR funct. LED (green) (LD1V) | out                     | 5V     | <1A    |  |
| 6    | SPOT function LED (LD4)                   | out                     | 5V     | <1A    |  |

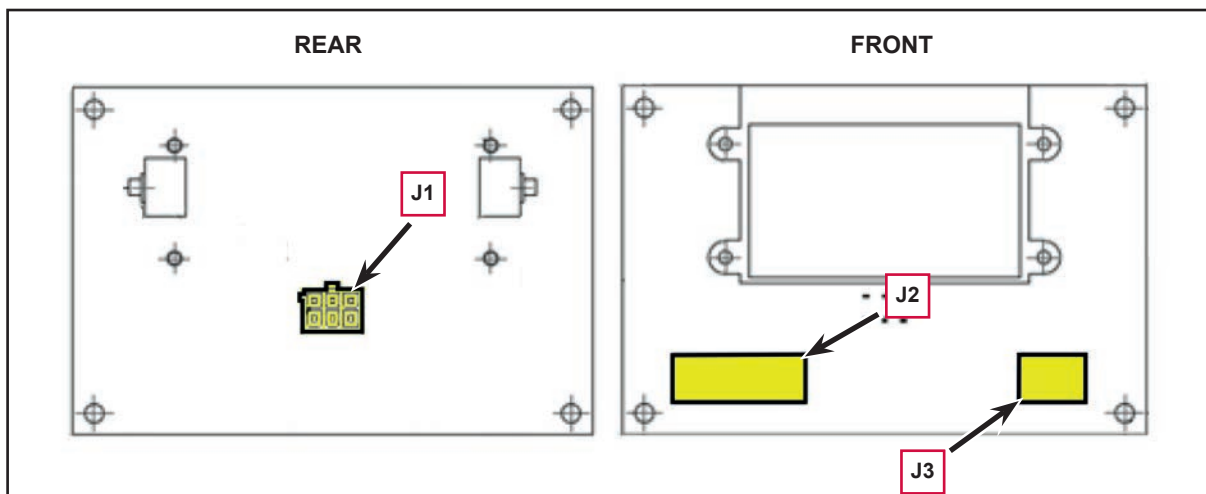


Figure 31

## Shop Measurements

The following tables contain some “real world” shop voltage measurements to help you recognize what “normal” looks like. All voltage values were measured with the black (Negative) voltmeter lead connected to the main battery negative unless otherwise specified.

### Shop Measurements - Function Electronic Board (EB1)

Battery volts at battery, key on = 24.55V (23.5V Vac on high).

#### Power Supply

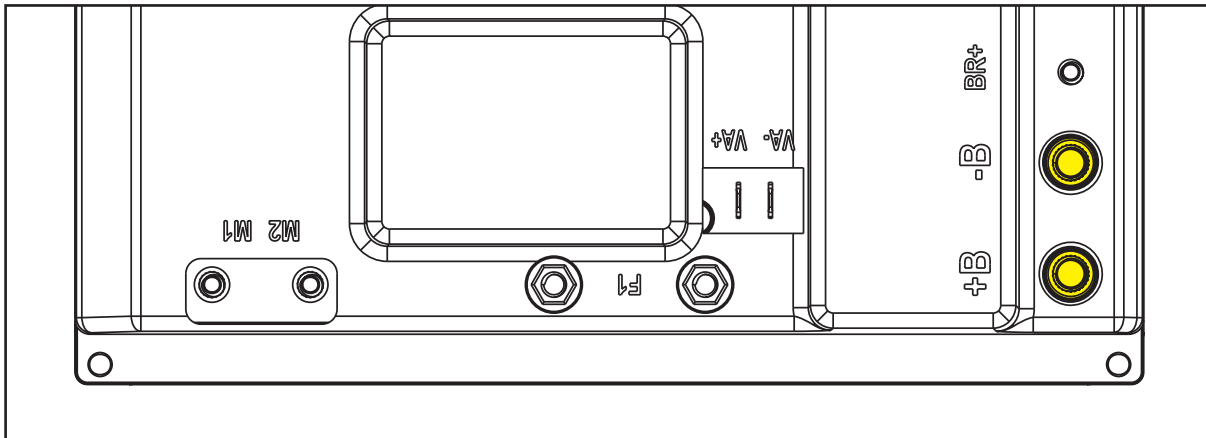


Figure 32

| PIN | Color | Description                     | Measured | Comments                       |
|-----|-------|---------------------------------|----------|--------------------------------|
| B+  | Red   | Electronic board power supply + | 23.4V    | Measured B+ to B-, Vac on high |
| B-  | Black | Electronic board power supply - | 23.4V    | Measured B+ to B-, Vac on high |

#### Brush Motor

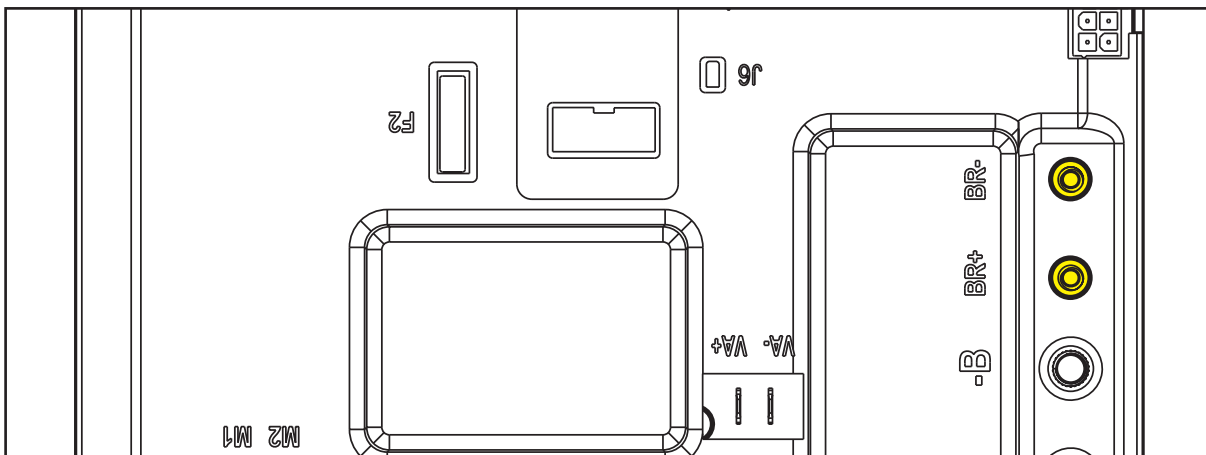


Figure 33

| PIN | Color | Description   | Measured | Comments                      |
|-----|-------|---------------|----------|-------------------------------|
| BR+ | Red   | Brush motor + | 23.5V    | Measured to BR-, normal scrub |
| BR- | Blue  | Brush motor - | 23.5V    | Measured to BR+, normal scrub |

## Shop Measurements - Function Electronic Board (EB1) (continues)

### Drive System Motor

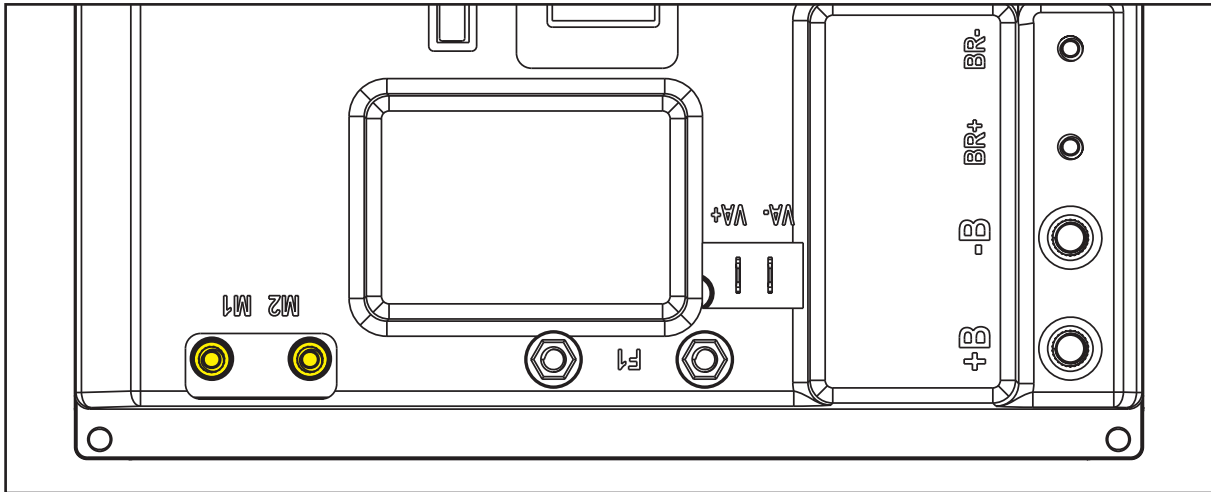


Figure 34

Specify if with operator on board or drive motor without load (machine lifted). The values seem a little bit low.

| PIN | Color | Description          | Measured  | Comments                       |
|-----|-------|----------------------|-----------|--------------------------------|
| M1  | White | Drive system motor + | 21.7V FWD | Measured M1 to M2 at Max speed |
|     |       |                      | 9.7V REV  |                                |
| M2  | Black | Drive system motor - | 21.7V FWD | Measured M1 to M2 at Max speed |
|     |       |                      | 9.7V REV  |                                |

### Vacuum Motor

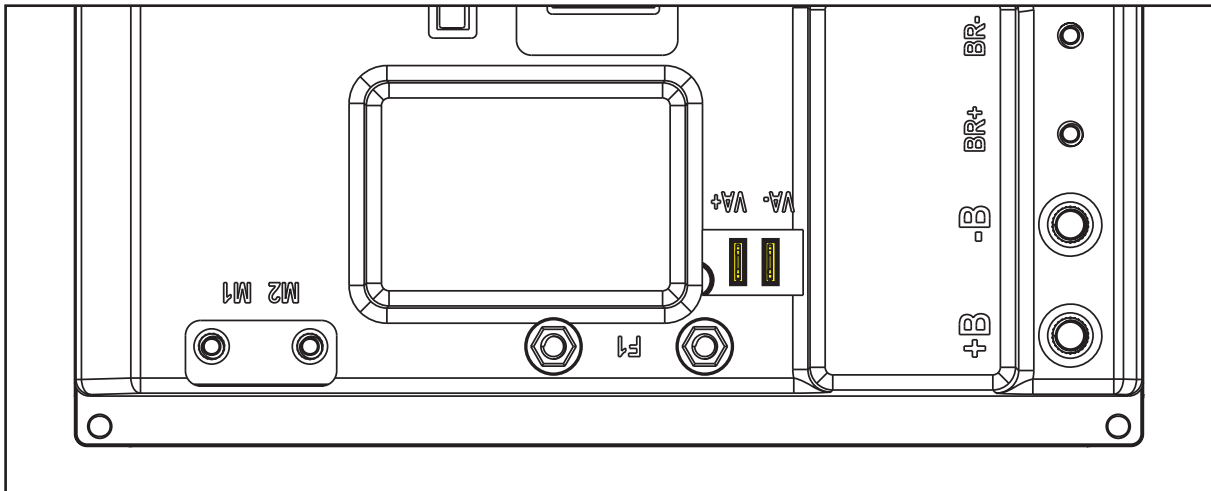


Figure 35

| PIN | Color | Description                  | Measured | Comments            |
|-----|-------|------------------------------|----------|---------------------|
| VA+ | Red   | Vacuum system power supply + | 23.2V    | Measured VA+ to VA- |
| VA- | Blue  | Vacuum system power supply - | 23.2V    | Measured VA+ to VA- |

## Shop Measurements - Function Electronic Board (EB1) (continues)

### J1 - 12 Ways

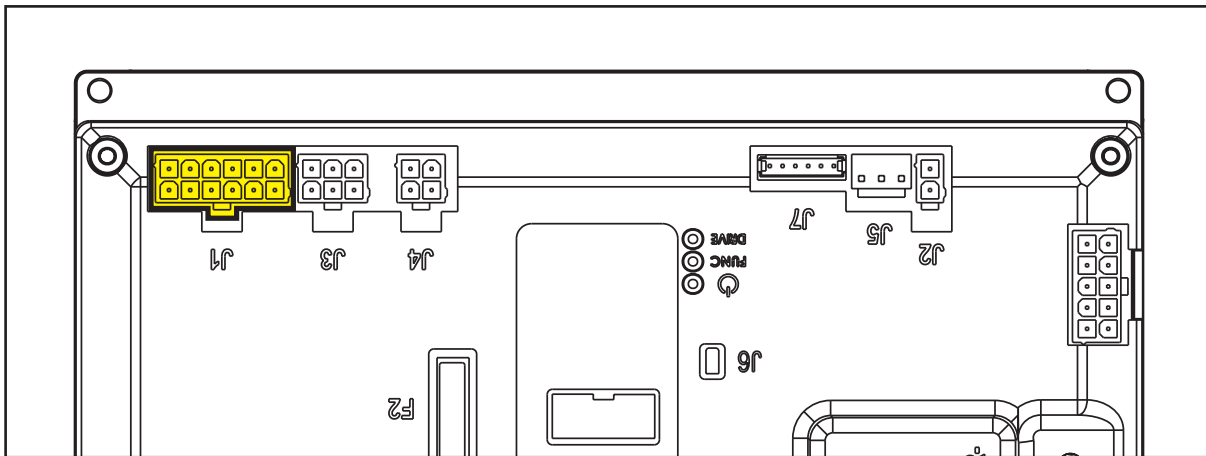


Figure 36

| PIN | Color  | Circuit Description                          | Measured | Comments                               |
|-----|--------|--|----------|--|
| 1   | Red    | Key electronic board power supply +          | 24.4V    | Off or On                              |
| 2   | Orange | Return from USER key                         | 0.02V    | Key not in slot                        |
|     |        |  | 23.7V    | With either gray or yellow key in slot |
| 3   | Or/Blk | Key reader power supply circuit              | 8.65V    | With either gray or yellow key in slot |
| 4   | Wh/Blk | Key Identification                           | 0V       | Key not in slot                        |
|     |        |  | 1.45V    | Gray Operator Key                      |
|     |        |  | 1.21V    | Yellow Super User Key                  |
| 5   | Black  | External power supplies -                    | 0.03V    | Vac On                                 |
| 6   | White  | Display electronic board power supply +      | 23.1V    | Key In (all condition)                 |
| 7   | Brown  | Enabling input from display electronic board | 0V       | Power Off (Timed out)                  |
|     |        |  | 22.7V    | Power On                               |
| 8   | Green  | Display electronic board serial +            | 4.5V     |  |
| 9   | Yellow | Display electronic board serial -            | 4.0V     |  |
| 10  | Violet | Pedal power supply +                         | 23.7V    |  |
| 11  | Vi/Blk | Return from pedal                            | 0.01V    | Pedal at rest                          |
|     |        |  | 4.82V    | Pedal pressed full forward             |
| 12  | Blue   | Return from steering microswitch             | 4.98V    | Straight ahead (switch pressed)        |
|     |        |  | 0.003V   | Sharp turn (Switch released)           |

### Shop Measurements - Function Electronic Board (EB1) (continues)

#### J2 - 2 Ways

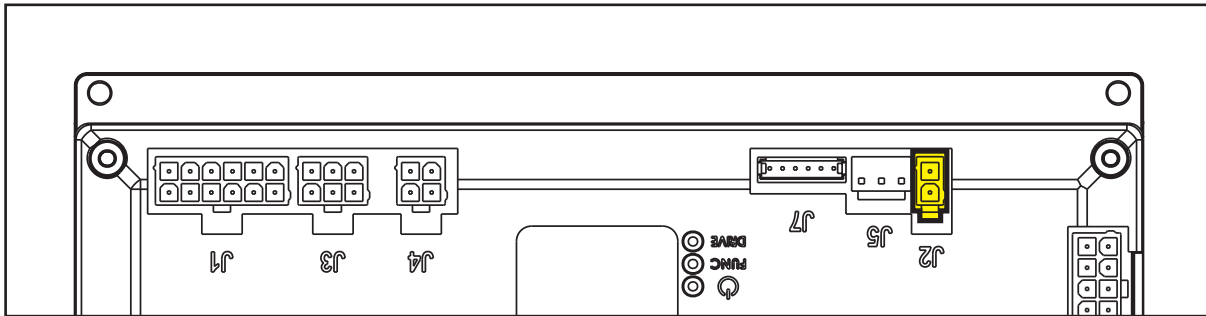


Figure 37

| PIN | Color   | Circuit Description            | Measured | Comments              |
|-----|---------|--------------------------------|----------|-----------------------|
| 1   | Black 2 | Deck actuator power supply +/- | 24.4V    | At rest               |
|     |         |                                | 0.04V    | Extending (deck down) |
|     |         |                                | 24.3v    | Retracting (deck up)  |
| 2   | Black 1 | Deck actuator power supply -/+ | 24.4V    | At rest               |
|     |         |                                | 23.7V    | Extending (deck down) |
|     |         |                                | 0.07V    | Retracting (deck up)  |

#### J3 - 6 Ways

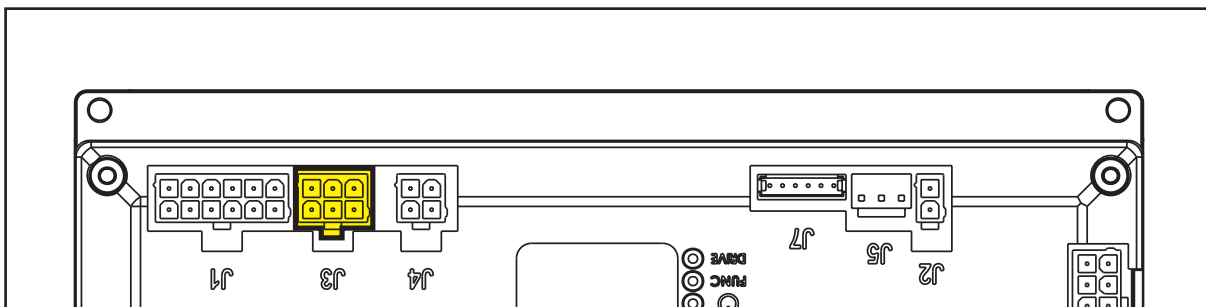


Figure 38

| PIN | Color  | Circuit Description                    | Measured | Comments                  |
|-----|--------|--|----------|---------------------------|
| 1   | Br/Blk | Squeegee actuator power supply +/-     | 23V      | At rest                   |
|     |        |  | 23.7V    | Extending (Squeegee down) |
|     |        |  | 0.07V    | Retracting (Squeegee up)  |
| 2   | Or/Blk | Driver's seat microswitch power supply | 0.02V    | On or off seat            |
| 3   | Wh/Blk | Auxiliary power supply - Beacon        | 0V       |                           |
| 4   | Bl/Blk | Squeegee actuator power supply -/+     | 0V       | At rest                   |
|     |        |  | 0.08V    | Extending (Squeegee down) |
|     |        |  | 23.9V    | Retracting (Squeegee up)  |
| 5   | Or/Blk | Return from driver's seat microswitch  | 4.98V    | Off seat                  |
|     |        |  | 0.003V   | On seat                   |
| 6   | White  | Auxiliary power supply + Beacon        | 24.39V   |                           |

### Shop Measurements - Function Electronic Board (EB1) (continues)

#### J4 - 4 Ways

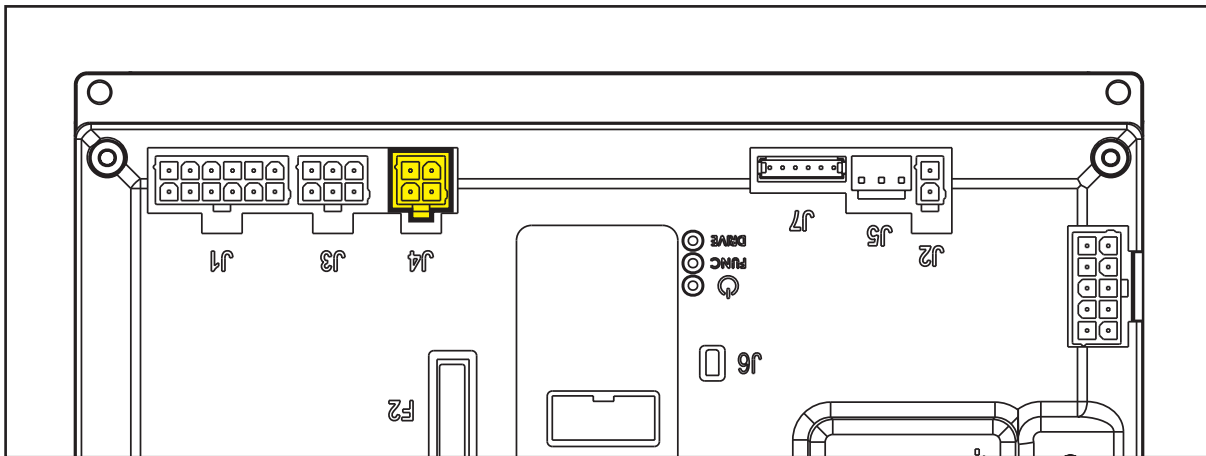


Figure 39

| PIN | Color  | Circuit Description                   | Measured | Comments     |
|-----|--------|---------------------------------------|----------|--------------|
| 1   | White  | Enabling from battery charger         | 24.4V    | Not Charging |
|     |        |                                       | 0.013V   | Charging     |
| 2   | Yellow | Power supply from battery charger     | 0.032V   | Not Charging |
|     |        |                                       | 24.4V    | Charging     |
| 3   | Brown  | Battery charger enabling power supply | 24.4V    | Not Charging |
|     |        |                                       | 26V      | Charging     |
| 4   | Green  | Battery charger data communication    | 0.01V    | Not Charging |
|     |        |                                       | 4.59V    | Charging     |

#### J5 - 3 Ways

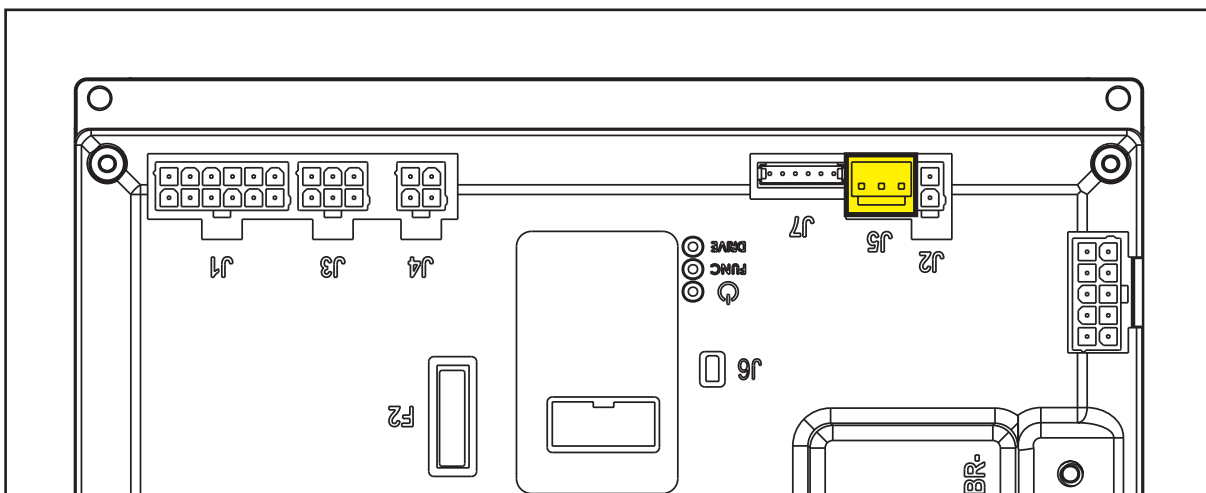


Figure 40

| PIN | Color | Circuit Description                   | Measured | Comments                  |
|-----|-------|---------------------------------------|----------|---------------------------|
| 1   | Brown | Power supply for water level sensor + | 21.6V    |                           |
| 2   | Black | Water level sensor return             | 4.9V     | < 1/2 solution tank level |
|     |       |                                       | 0.03V    | > 1/2 solution tank level |
| 3   | Blue  | Power supply for water level sensor - | 0.001V   |                           |



## Shop Measurements - Function Electronic Board (EB1) (continues)

### J6 - 2 Ways

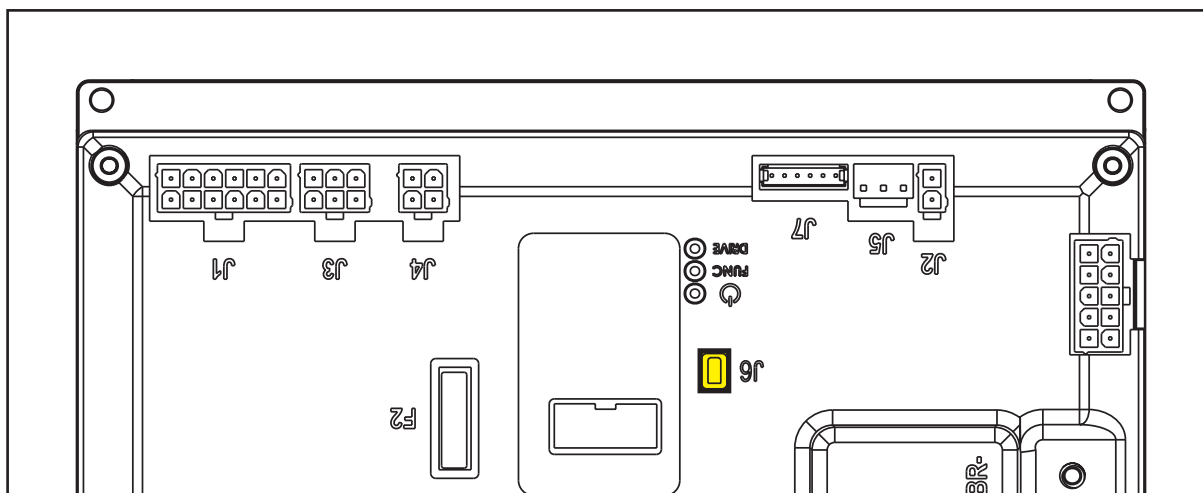


Figure 41

Two way vertical jumper.

- What is this for? The J6 Jumper is used to configure the function board for the EcoFlex option.
- What does it mean if it is jumped? The function board is set for no EcoFlex
- What does it mean if it is open? The function board is set for EcoFlex
- Is there a measurable voltage on either of the pins when not jumped? Yes. 4.98v on pin near the LEDS on the board.

### J7 - 6 Ways

Measured machine did not have a wiring connector. Measurements were taken at each pin on the board.

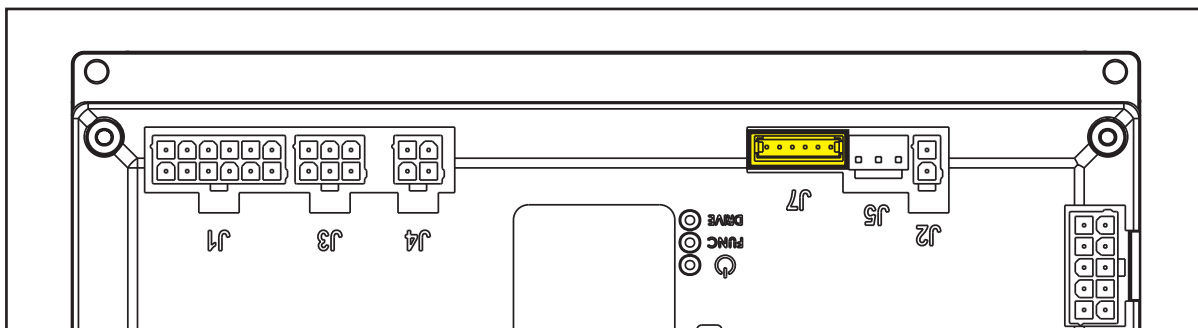


Figure 42

| PIN | Color  | Circuit Description           | Measured | Comments |
|-----|--------|-------------------------------|----------|----------|
| 1   | Red    | +24V power supply             | 24.6V    |          |
| 2   | -      | +5V power supply              | 5.00V    |          |
| 3   | Yellow | iButton input                 | 4.98V    |          |
| 4   | Blue   | External time counter enabled | 24.6V    |          |
| 5   | White  | Power supply -                | 0.001V   |          |
| 6   | Brown  | Machine on signal             | 23.68V   |          |

### Shop Measurements - Function Board (EB1) (continues)

#### J8 - 10 Ways

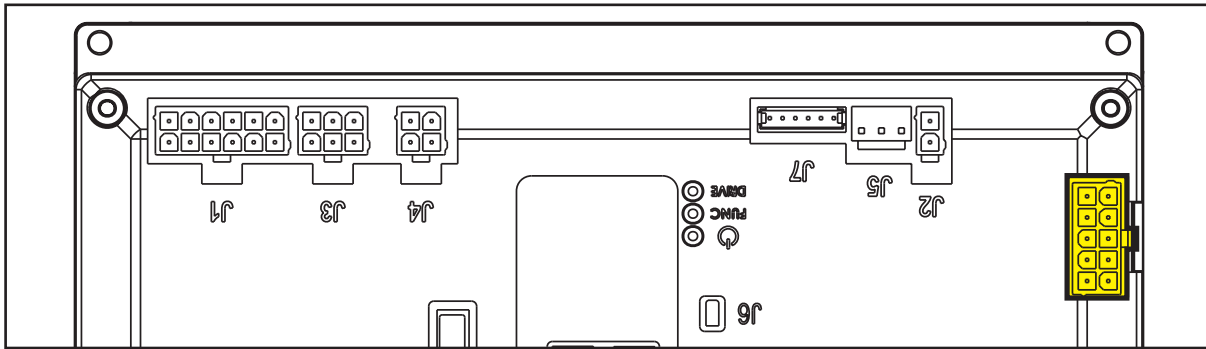


Figure 43

| PIN | Color  | Circuit Description                | Measured | Comments                   |
|-----|--------|------------------------------------|----------|----------------------------|
| 1   | Blue   | Solenoid valve power supply -      | 24.2V    | When off                   |
|     |        |                                    | 0.08v    | When on (momentary)        |
| 2   | Black  | Detergent pump power supply -      | 24.2V    | When off                   |
| 3   | Wh/Blk | Electromagnetic brake output       | 24.1V    | Not energized (stationary) |
|     |        |                                    | 0.7V     | Energized (moving)         |
| 4   | Black  | Opt power supply -                 |          | No wire                    |
| 5   | Green  | DECK configurator return           | 0V       | Loop not cut               |
| 6   | Brown  | Solenoid valve power supply +      | 24.2V    |                            |
| 7   | Grey   | Detergent pump power supply +      | 24.2V    |                            |
| 8   | White  | Electromagnetic brake output +     | 24.2V    |                            |
| 9   | Red    | Opt power supply +                 |          | No wire                    |
| 10  | Green  | Power supply for DECK configurator | 0V       | Loop not cut               |

### Shop Measurements - Display Electronic Board (EB2)

Measure and record the voltage at each of the function board pins. Always use battery negative as your reference point for your black voltmeter lead.

#### J1 - 6 Ways

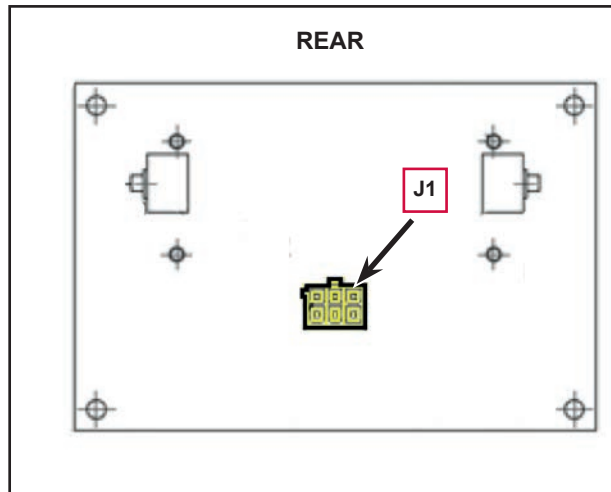


Figure 44

| PIN | Color  | Circuit Description               | Measured | Comments               |
|-----|--------|-----------------------------------|----------|------------------------|
| 1   | White  | Power supply +                    | 23.1V    | Key In (all condition) |
| 2   | Brown  | Machine startup enabling          | 0V       | Power Off (Timed out)  |
|     |        |                                   | 22.7V    | Power On               |
| 3   | Green  | Display electronic board serial + | 4.5V     |                        |
| 4   | Yellow | Display electronic board serial - | 4.0V     |                        |
| 5   | Grey   | Power supply -                    | 0.03V    | Vac On                 |
| 6   |        | Power supply repetition -         |          | No wire                |

## Shop Measurements - Display Electronic Board (EB2) (continues)

### J2 12 way ribbon connector

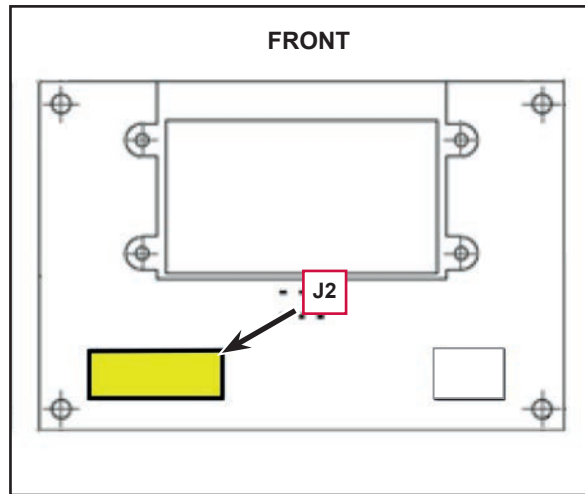


Figure 45

| PIN | Color | Circuit Description                         | Measured | Comments    |
|-----|-------|---|----------|-------------|
| 1   |       | Power supply - common                       | 0.007V   |             |
| 2   |       | HORN button (P3)                            | 3.1V     | Not pressed |
|     |       |   | 0.03V    | Pressed     |
| 3   |       | EDS button (P2) Solution Button             | 3.1V     | Not pressed |
|     |       |   | 0.03V    | Pressed     |
| 4   |       | DETERGENT MIX button (P1)                   | 3.1V     | Not pressed |
|     |       |   | 0.1V     | Pressed     |
| 5   |       | BRUSH / EXTRAPR. button (P4)                | 3.1V     | Not pressed |
|     |       |   | 0.07V    | Pressed     |
| 6   |       | VACUUM button (P5)                          | 3.1V     | Not pressed |
|     |       |   | 0.06V    | Pressed     |
| 7   |       | BRUSH RELEASE button (P6)                   | 3.1V     | Not pressed |
|     |       |   | 0.04V    | Pressed     |
| 8   |       | ON/OFF button (P0)                          | 22.1V    | Not pressed |
|     |       |   | 0.02V    | Pressed     |
| 9   |       |   | 3.1V     |             |
| 10  |       |   | 3.1V     |             |
| 11  |       | REVERSE GEAR button (P7) (Blue models only) | 3.1V     | Not pressed |
|     |       |   | 0.06V    | Pressed     |
| 12  |       | Dashboard configurator                      | 3.1V     | Gray model  |
|     |       |   | 0.01V    | Blue model  |

## Shop Measurements - Display Electronic Board (EB2) (continues)

### J3 6 way ribbon connector

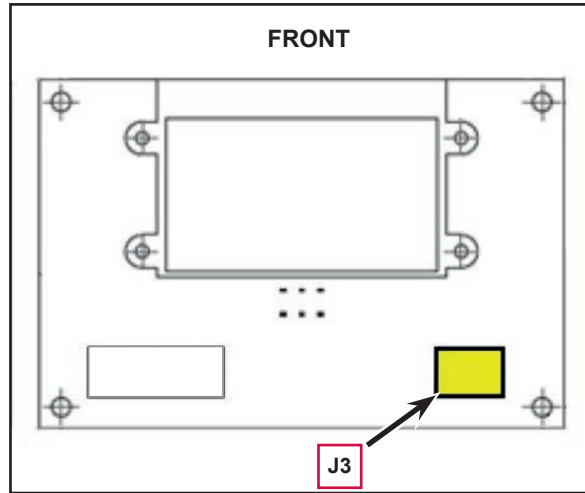


Figure 46

| PIN | Color | Circuit Description                       | Measured | Comments          |
|-----|-------|---|----------|-------------------|
| 1   |       | Power supply – common                     | 0.007V   |                   |
| 2   |       | BRUSH RELEASE function LED (LD3)          | 0.01V    | Off               |
|     |       |   | 0.9V     | When flashing red |
| 3   |       | VACUUM function LED (LD2)                 | 0.01V    | Off               |
|     |       |   | 2.0V     | Steady green      |
| 4   |       | BRUSH / EXTRAPR funct. LED (red) (LD1R)   | 0.01V    | Off               |
|     |       |   | 2.0V     | Steady red        |
| 5   |       | BRUSH / EXTRAPR funct. LED (green) (LD1V) | 0.01V    | Off               |
| 6   |       | SPOT function LED (LD4)                   | 2.0V     | Steady green      |

# Electrical System

## Functional Description

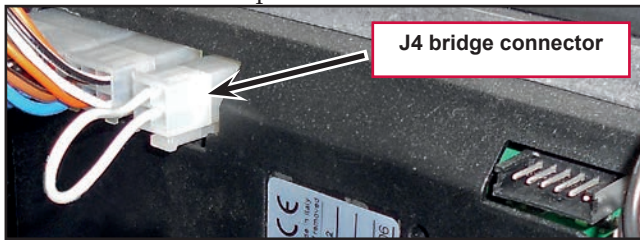
The batteries (2 x 12V) are connected together in series by the cables.

The battery charger (CH) is connected to the machine by two connectors (C) (power connection to the batteries) and C3 (4-way signal connection).

The grey and white cables (1 and 2 of connector C3) are short circuited inside the battery charger (CH) when this is not connected to the electrical mains. If this connection is not made, all machine functions are disabled.

If the optional battery charger has not been installed, the relevant bridge must be used on connector C3.

The “bridge” is installed at the function board J4 location as shown in a photo below.



The green cable (terminal 4 of connector C3) is the data cable between electronic board (EB1) and battery charger (CH).

This connection allows the battery charger charging curve to be set directly from the machine dashboard and to view the operational state of the battery charger during charging directly on the dashboard display.

## Battery Charger

When the battery charger (CH) is connected to the power supply, it provides a + 24V on J4.2: in this condition the electronic board (EB1) disables all the control and functions except the battery status indicator on the display electronic board (EB4).

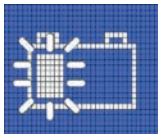
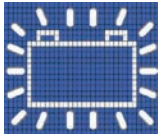
## Battery Charge State Display

### Low voltage cut out

The Function electronic board shuts off electrical loads to protect the batteries from damage caused by over discharging.

The voltage threshold where loads are turned off depends on the battery type. See table below.

### (Significant levels for machine operation)

|   | INDICATION  | TRANSITION THRESHOLD (VOLT) |       | CONSEQUENCE                          |
|---|---|-----------------------------|-------|--------------------------------------|
|   |   | WET                         | GEL   |                                      |
| 1 |  | 22V                         | 22.2V | Little remaining run time, no block. |
| 2 |  | 20.4V                       | 21.6V | Brush OFF                            |
| 3 |   | 19.4V                       | 20.6V | Vacuum system OFF                    |
| 4 |   | 18.4V                       | 19.6V | Drive system OFF                     |

## Wiring Diagram

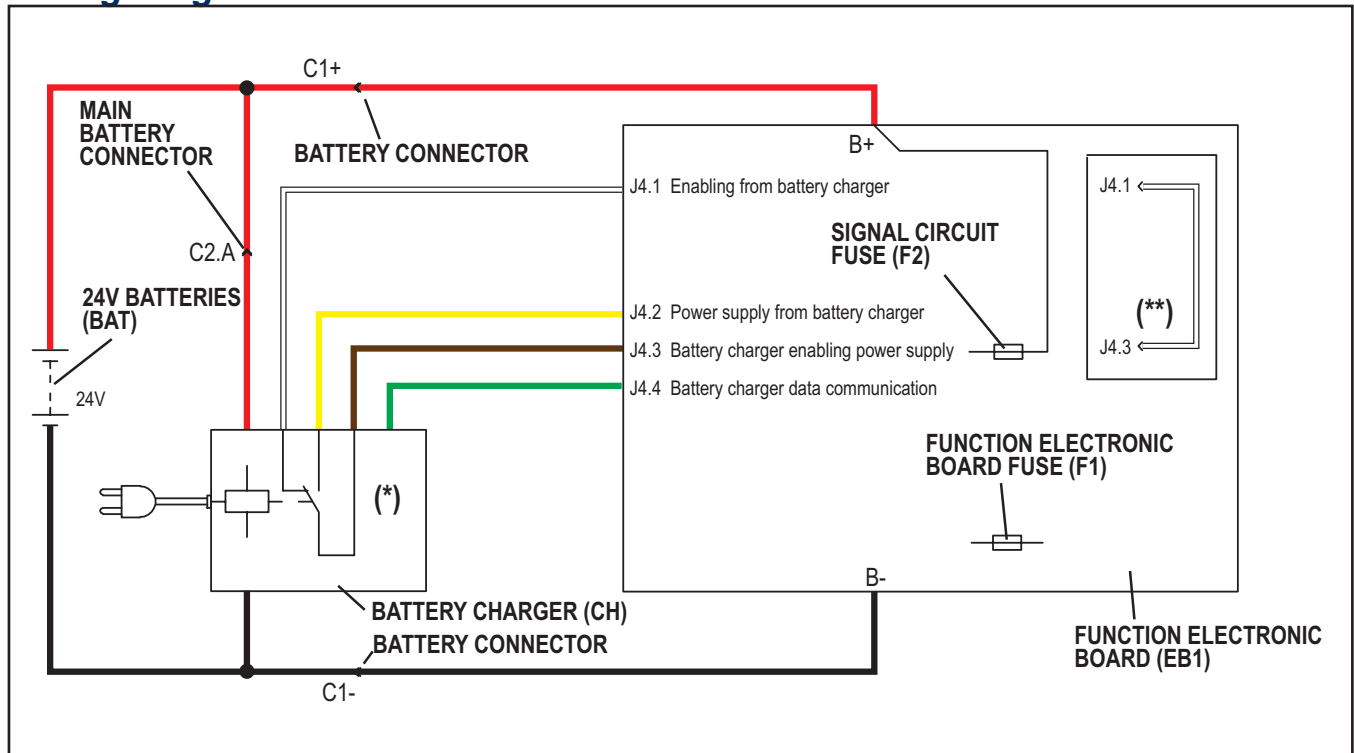


Figure 1

(\*) Optional for BASIC version

(\*\*) Version without on-board battery charger

### Component Locations

- Function electronic board (EB1)
- Signal circuit fuse (F2)
- Function electronic board fuse (F1)
- Battery charger (CH)
- Battery connections
- Batteries (BAT)
- Battery connector (C1)

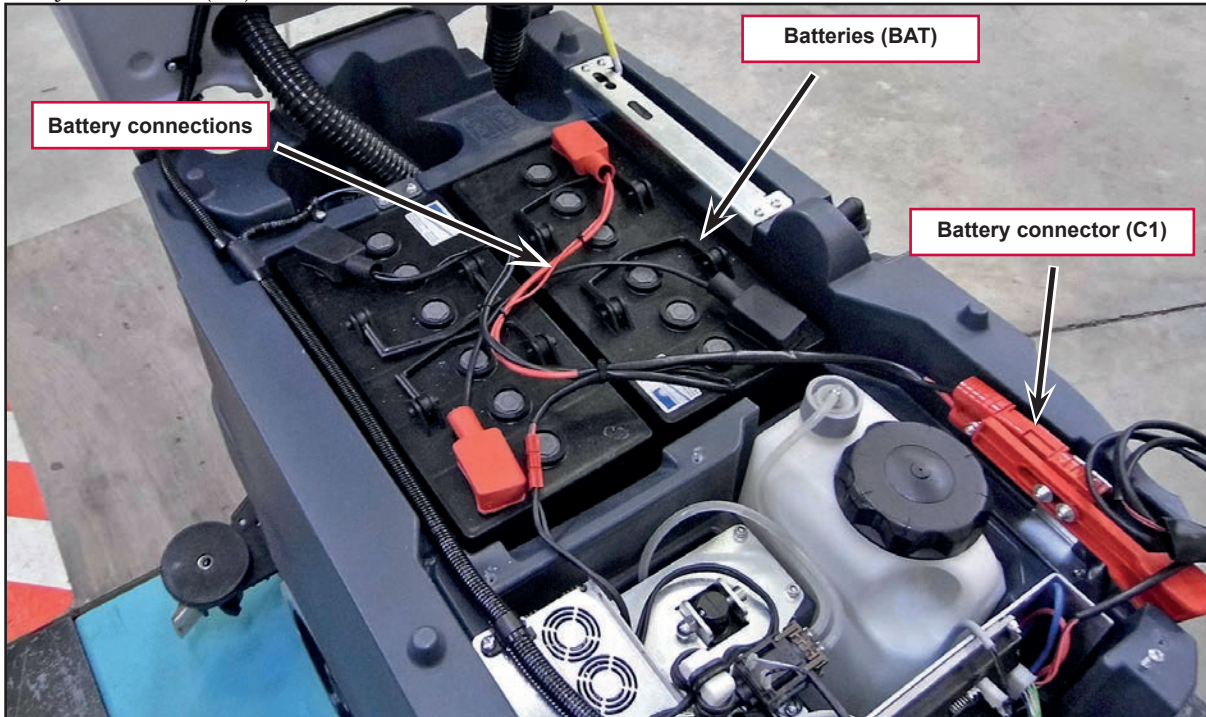


Figure 2

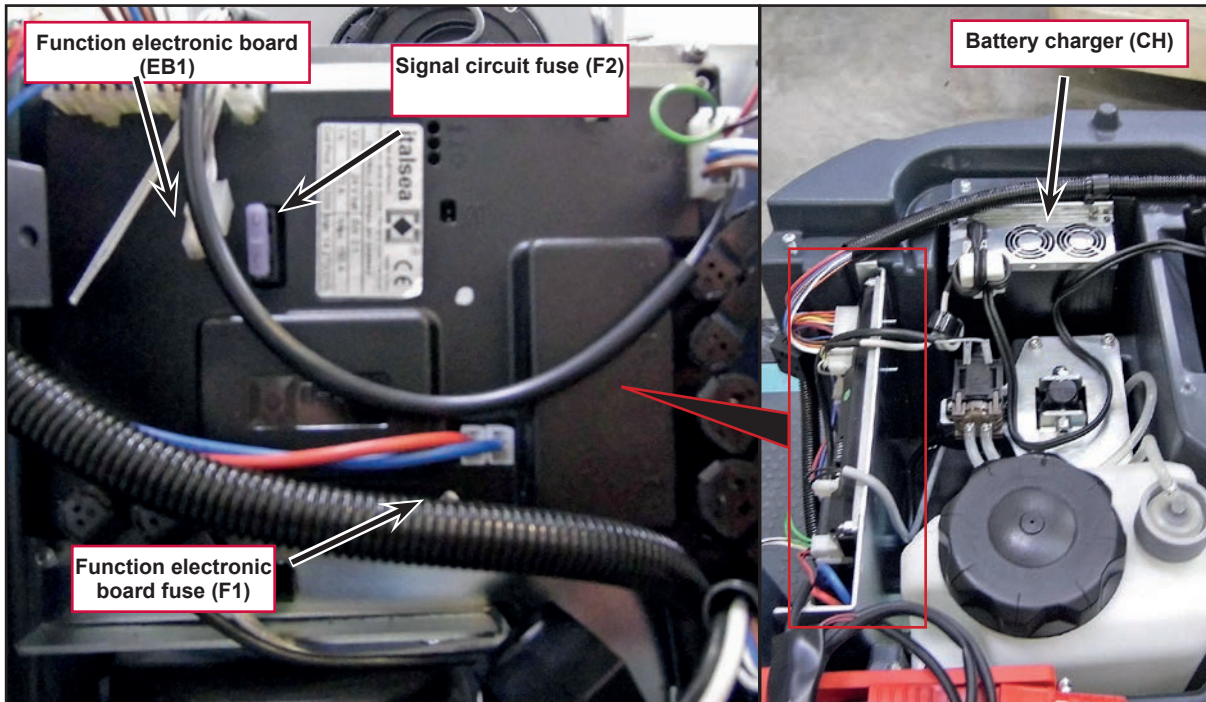


Figure 3



## Component Locations (continues)

- On board battery charger connector (C2)
- J4 Bridge for without or broken on board battery charger

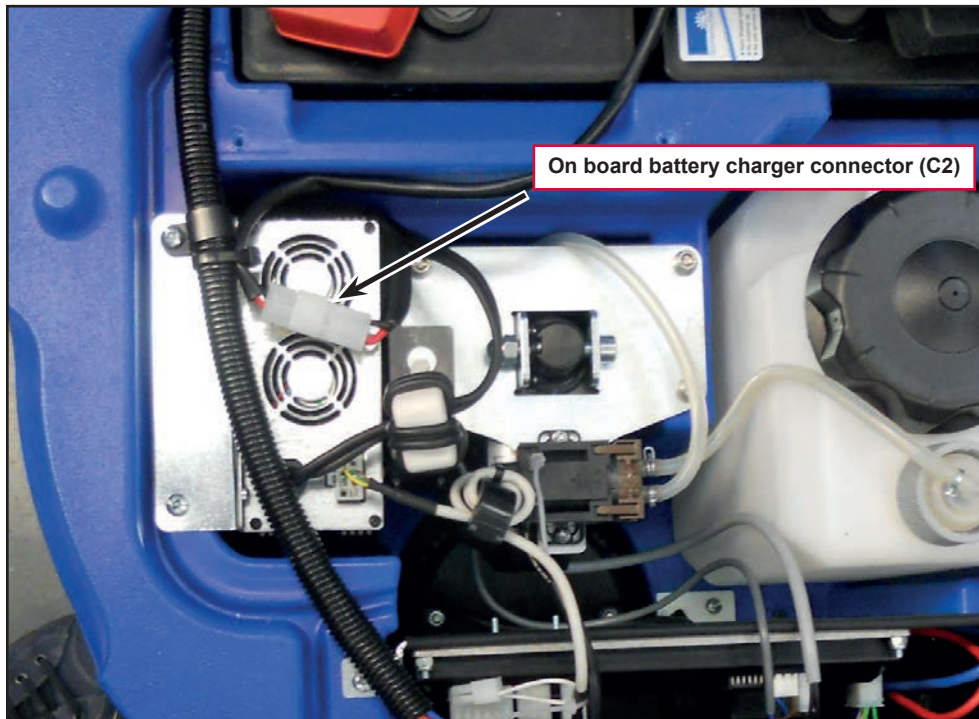


Figure 4

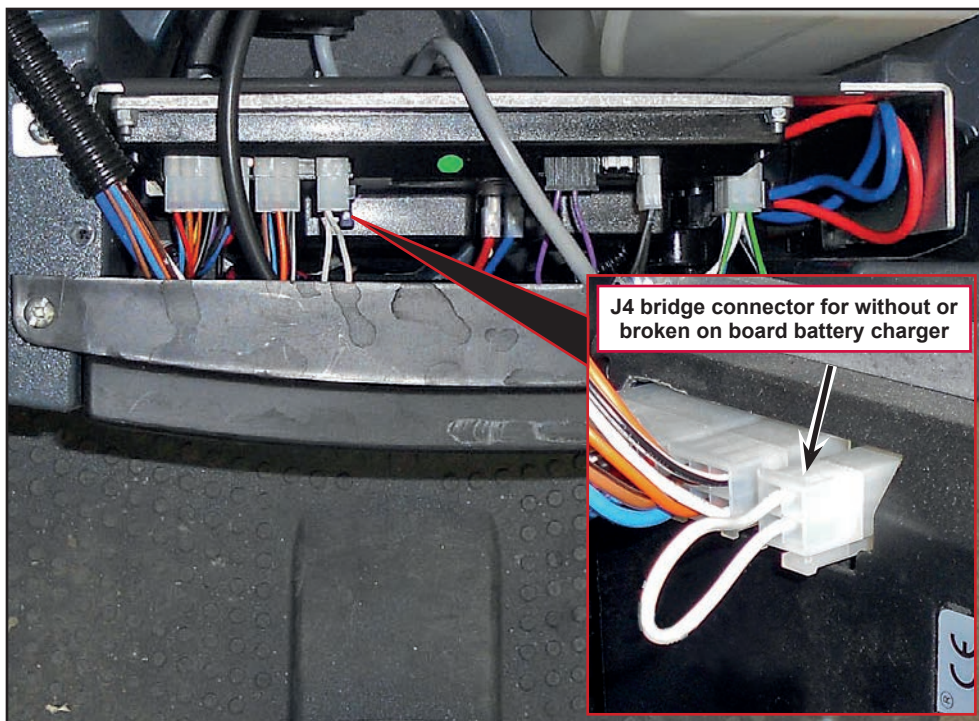


Figure 5

## Maintenance and Adjustments

### Setting the Installed Battery Type

Set the machine and the on-board battery charger (where fitted) on the basis of the type of battery to be installed by modifying the BAT parameter as shown.

1. Turn the ignition key to “I” holding down both the horn button (A, Figure 6) together with the adjustment percentage detergent button (B) to going at the function parameters screen (C).
2. Press the reverse button (F) until you reach the BAT parameter.

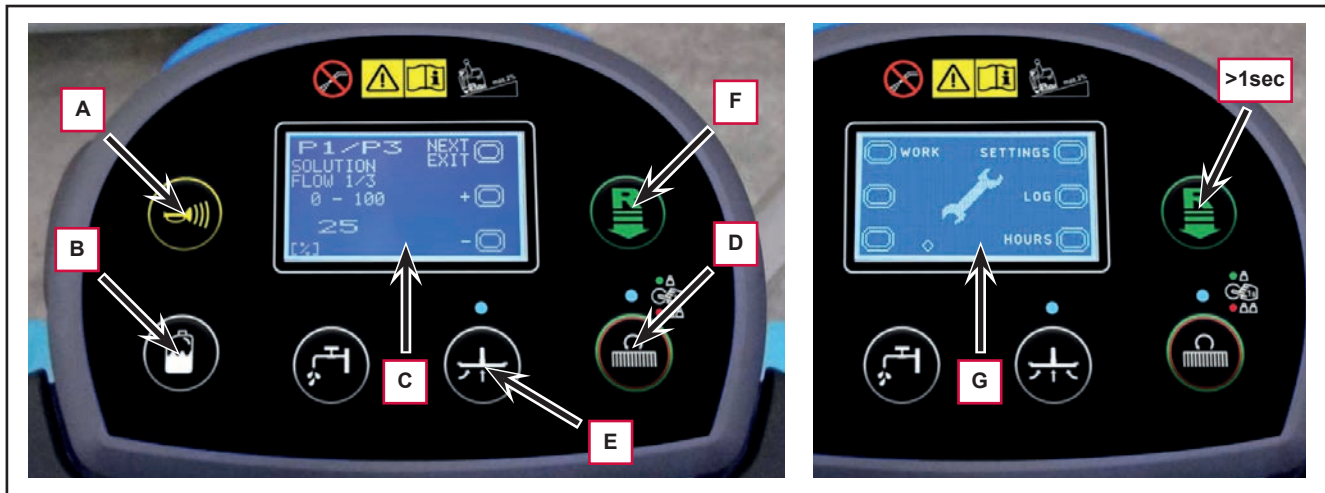


Figure 6

| MODIFIABLE PARAMETERS |                        |            |                 |            |
|-----------------------|------------------------|------------|-----------------|------------|
| Code                  | Description            | Min. Value | Factory Setting | Max. Value |
| BAT                   | Installed battery type | 0          | 1               | 5          |

3. Press the One-Touch button (D) or the vacuum system button (E) to modify the value of the BAT parameter as per the following table:

| Code BAT |                        |  |
|----------|------------------------|--|
| Value    | Installed battery type |  |
| 0        | WET                    | Wet cell batteries                     |
| 1        | GEL / AGM              | Generic GEL or AGM batteries           |
| 2        | GEL DISCOVER           | DISCOVER® brand GEL batteries          |
| 3        | GEL OPTIMA             | OPTIMA™ brand GEL batteries            |
| 4        | GEL EXIDE              | EXIDE®/SONNENSHINE brand GEL batteries |
| 5        | GEL FULLRIVER          | FULLRIVER® brand GEL batteries         |

4. Press the reverse button (F) for more than 1 second to confirm the chosen parameter and return to the screen menu (G).
5. To return to the work screen press the adjustment percentage detergent button (B).

## Battery Charging (Continues)



**Warning!** When using lead (WET) batteries, battery charging produces highly explosive hydrogen gas. Charge the batteries in well-ventilated areas and away from naked flames. Do not smoke while charging the batteries. Keep the recovery tank lifted until the battery charging cycle is over.



**Warning!** Pay close attention when charging WET CELL batteries, as there may be battery fluid leakages. The battery fluid is corrosive. If it comes in contact with skin or eyes, rinse thoroughly with water and consult a physician.

1. (For WET CELL batteries only) Check the level of electrolyte inside the batteries. If necessary, unscrew the caps and top up.
2. When the correct level is restored, close the caps and clean the tops of the batteries.

### Charging the Batteries with an External Battery Charger

1. Check that the external battery charger is suitable by referring to the relevant Manual. The battery charger voltage rating must be 24V.
2. Press the emergency push-button, disconnect the red battery connector and connect it to the external battery charger.
3. Connect the battery charger to the electrical mains.
4. After charging, disconnect the battery charger from the electrical mains and from the battery red connector.
5. Connect the battery connector to the machine.
6. Disengage the support rod, then grasp the handle and carefully lower the recovery tank assembly.



**Note:**

*For further information about the operation of the battery charger, see the relevant Manual.*

### Battery charging with battery charger installed on the machine

7. Plug the battery charger into the electrical mains (the mains voltage and frequency must be compatible with the battery charger values shown on the machine serial number plate).

**Note:** When the battery charger is connected to the electrical mains, all machine functions are automatically cut off.



## Battery installation

1. Remove the operator key.
2. Disconnect the battery connector by pressing the emergency push-button.
3. Lift the recovery tank cover and check that it is empty; if not, empty it using the drain hose.
4. Grasp the handle and carefully lift the recovery tank assembly and the driver's seat.
5. The machine is supplied with cables suitable to install 2 12V batteries.
6. Carefully lift the batteries until the relevant compartment, then place them properly.
7. Route and install the battery cable as shown in the diagram (Figure 7), then carefully tighten the nut on each battery terminal.
8. Place the protection cap on each terminal.
9. Connect the red battery connector.
10. Disengage the support rod, then grasp the handle and carefully lower the recovery tank assembly.
11. Perform a complete battery charging cycle.

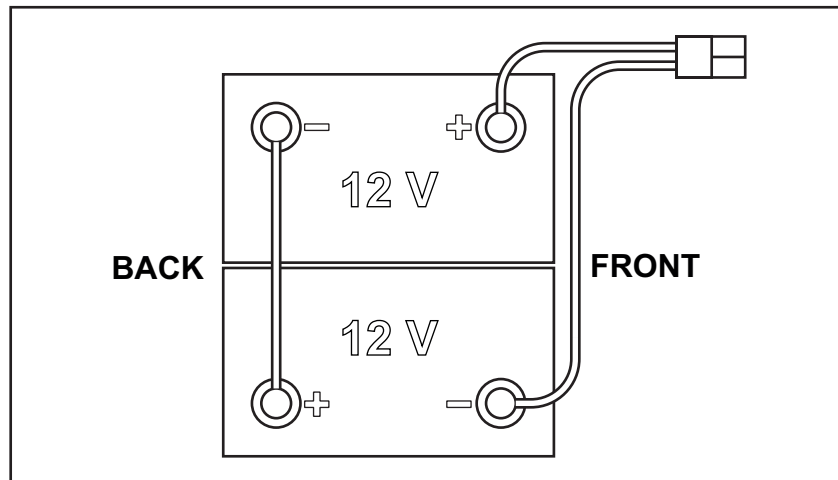


Figure 7

## Battery Charging



**Note:** Charge the batteries when there is only one flashing segment displayed in the battery symbol, or at the end of each shift. Keeping the batteries charged make their life last longer.



**Caution!** When the batteries are discharged, charge them as soon as possible, as that condition makes their life shorter. Check for battery charge at least once a week.



**Caution!** If the machine is not equipped with on-board battery charger, choose an external battery charger suitable for the type of batteries installed.

## Checking/Replacing Fuses

1. Drive the machine on a level floor and remove the operator key.
2. Disconnect the red battery connector by pressing the emergency push-button.
3. Lift the recovery tank.
4. Remove the 3 screws and remove the upper cover.
5. Remove the 2 screws and remove the electronic board front cover.
6. Check/replace the following fuses (Figure 8):
  - (F1) 100A midi fuse - Function electronic board (A).
  - (F2) 3A blade fuse - Signal circuits (B).
7. Place the function electronic board assembly in its housing, tighten the mounting screws and install the electronic component compartment cover.

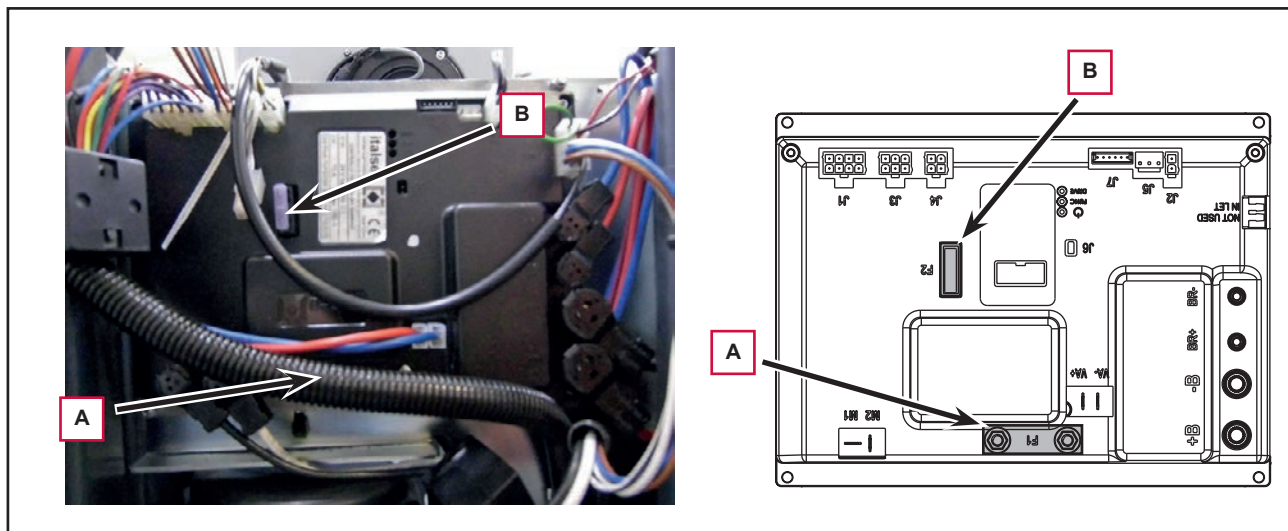


Figure 8

## Troubleshooting

See the other chapters for previously provided instructions for other electrical system components.

| Trouble                          | Possible Causes   | Remedy   |
|----------------------------------|---|--|
| The machine is not working       | Batteries (BAT) flat or connections faulty              | Charge the battery or clean the connections  |
|                                  | The batteries (BAT) are broken                          | Check the battery no-load voltage  |
|                                  | The battery charger (CH) is broken                      | Replace  |
|                                  |   | To restore the machine functioning, disabling the on board battery charger with sthe bridge connector on the J4 connection placed on the function electronic board (EB1) |
|                                  | The wiring harness is cut or pressed or short circuited | Repair   |
| The ignition key (SW1) is broken | Replace   |  |



*Note:*

*A damage to the battery charger or its connections can prevent the machine from operating properly.*

## Specifications

| Description / Model                                |                                | Nilfisk<br>Scubtec R253          | Nilfisk<br>Scubtec R253 full PKG<br>Clarke RA40 |
|--|--------------------------------|----------------------------------|---|
| Battery compartment size (length x width x height) |                                | 13.7x14.1x11 in (350x360x280 mm) |   |
| Standard batteries (2)                             |                                | Discover 12V-105Ah               |   |
| Standard battery run time (capacity)               |                                | 2.5 h                            |   |
| Battery charger                                    | Input voltage                  | 100-240Vac 50-60Hz, 24Vdc 13A    |   |
|  | Charging procedure             | by microprocessor                |   |
|  | Efficiency                     | > 85 %                           |   |
|  | Environmental protection class | IP30                             |   |

Wiring Diagram

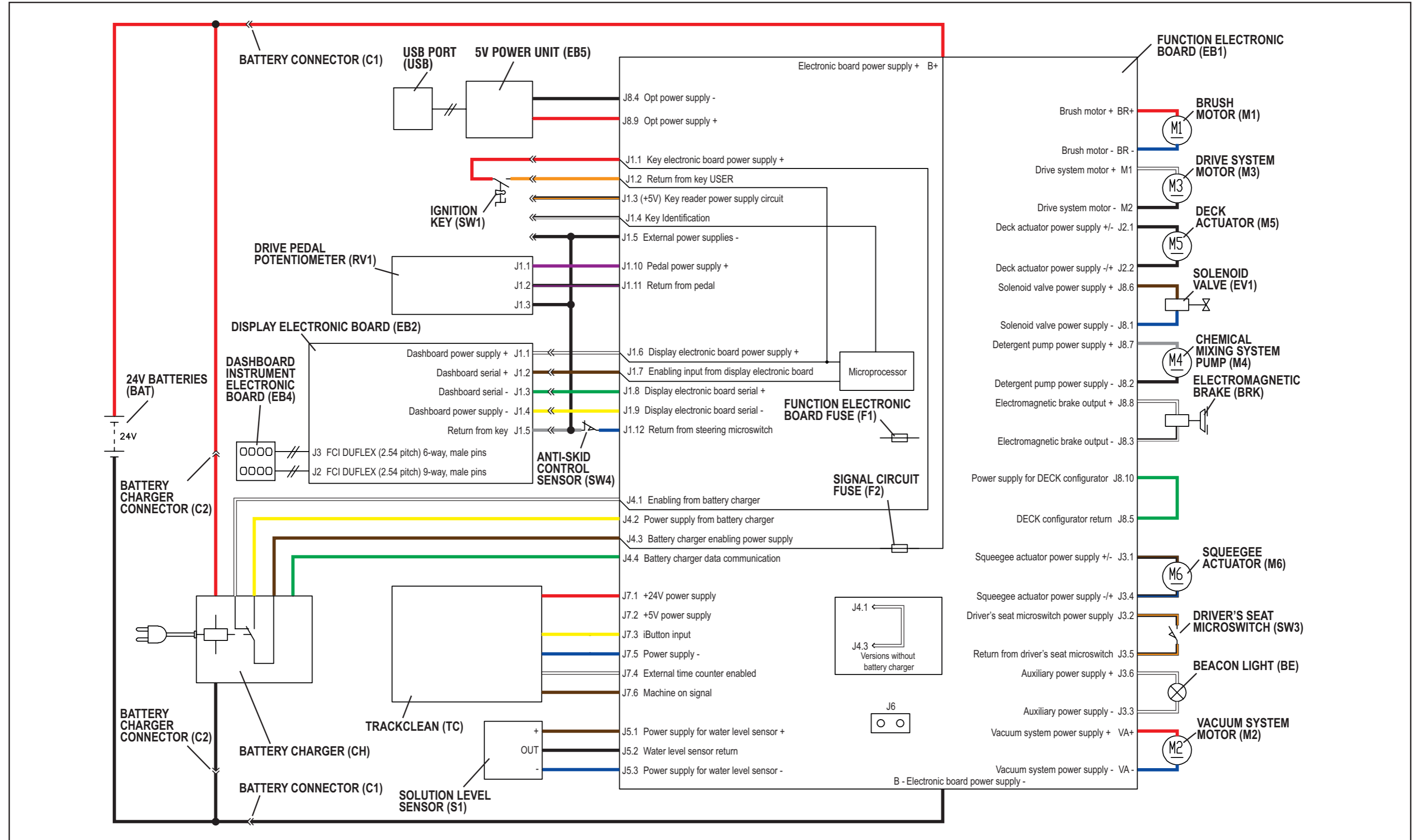






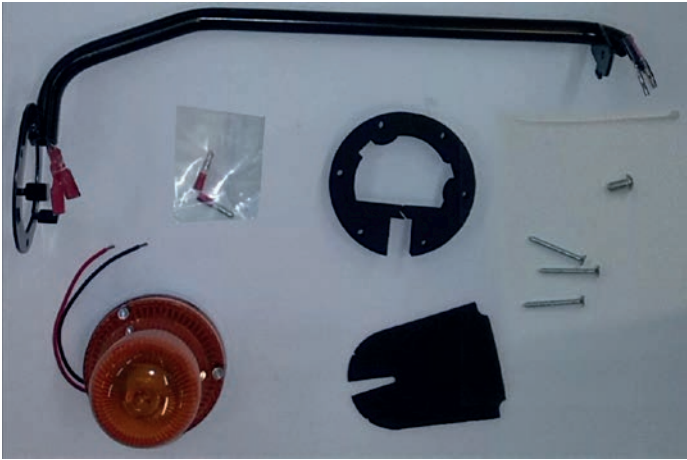
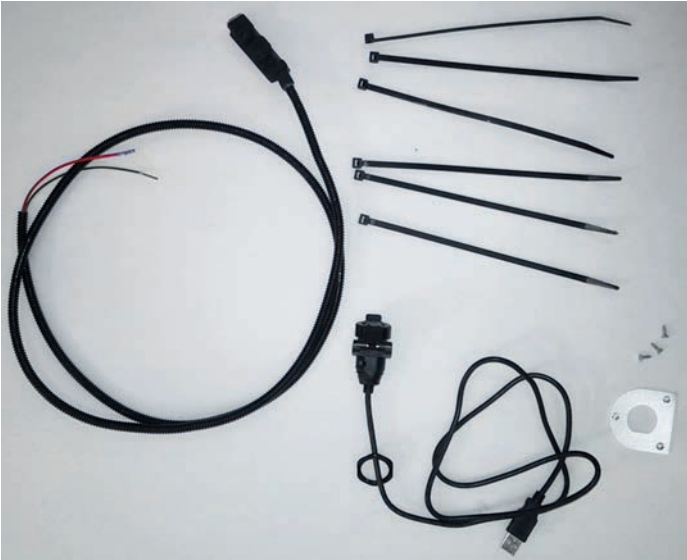
Figure 8

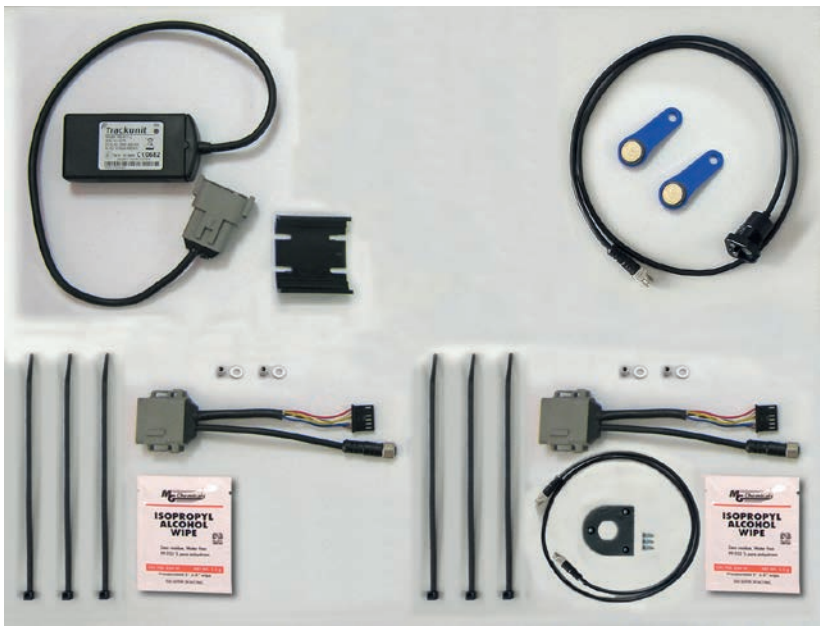


## Options and Accessories

| Description   | Illustration   |
|---|--|
| <p><b>CHEMICAL MIXING SYSTEM KIT</b><br/>(EU model only)</p> <p>Insert-dry brake<br/>Cap<br/>Refill cap<br/>Hose<br/>Pump chemical mix<br/>Sensor water level<br/>Support sensor<br/>Hardware</p> |    |
| <p><b>BATTERY CHARGER KIT</b><br/>(EU model only)</p> <p>Charger extension UK / EU<br/>Cable tie plug<br/>Charger battery<br/>Support battery charger<br/>Hardware</p>                            |   |
| <p><b>WASTE BASKET KIT</b><br/>(EU model only)</p> <p>Support<br/>Basket<br/>Hardware</p>   |  |

| Description   | Illustration   |
|---|--|
| <p><b>BROOM HOLDER KIT</b><br/>(EU model only)</p> <p>Support mop<br/>Spacer for support<br/>Tool holder<br/>Hardware</p> |    |
| <p><b>ENHANCED VACUUM SYSTEM MOTOR KIT</b><br/>(EU model only)</p> <p>Vacuum motor assembly<br/>Hardware</p>              |   |
| <p><b>WATER FILLER HOSE KIT</b></p> <p>Support rubber for filling hose<br/>Hose filling<br/>Hardware</p>                  |  |

| Description  | Illustration   |
|--|--|
| <p><b>STOP WATER KIT</b></p> <p>Solution cap<br/>                     Fitting quick 1/2 gas<br/>                     Valve water stop<br/>                     Support<br/>                     Hardware</p> |    |
| <p><b>BEACON LIGHT KIT</b></p> <p>Support<br/>                     Beacon<br/>                     Hardware</p>  |   |
| <p><b>USB KIT</b></p> <p>USB cable<br/>                     Plate<br/>                     Hardware</p>  |  |

| Description   | Illustration   |
|---|--|
| <p><b>TRACKCLEAN KIT</b></p> <p>Trackclean sensor assy<br/>Mounting cradle<br/>Trackclean system (IButton)<br/>Trackclean reader kit (reader, 2 keys)<br/>Trackclean system RDR</p> |  |

# Recovery System

## Functional Description

The recovery system removes the dirty water from the floor and pipes it to a recovery tank. When the machine is running, the dirty water on the floor is collected by the squeegee blades and collected through the slots in the same, piped through the vacuum hose and into the tank by the airflow created by vacuum system motor (M2). The dirty water is piped into the recovery tank, while the airflow continues to the vacuum fan.

A tank with a grid collects the largest debris going through the recovery tank hose.

The automatic float in the vacuum grid stops vacuum system motor (M2) from collecting any liquids.

The vacuum duct for connecting the vacuum grid to the vacuum system motor (M2) is inside the recovery tank cover.

When the automatic float closes and shuts down the vacuum system, the vacuum system motor noise will increase and the floor will not be dried.

The gasket on the input of the vacuum system motor allows full functionality of the system, while the filter built-in the gasket prevents the passage of dirt and debris.

When the recovery tank is full it can be emptied through the drain hose.

## Wiring Diagram

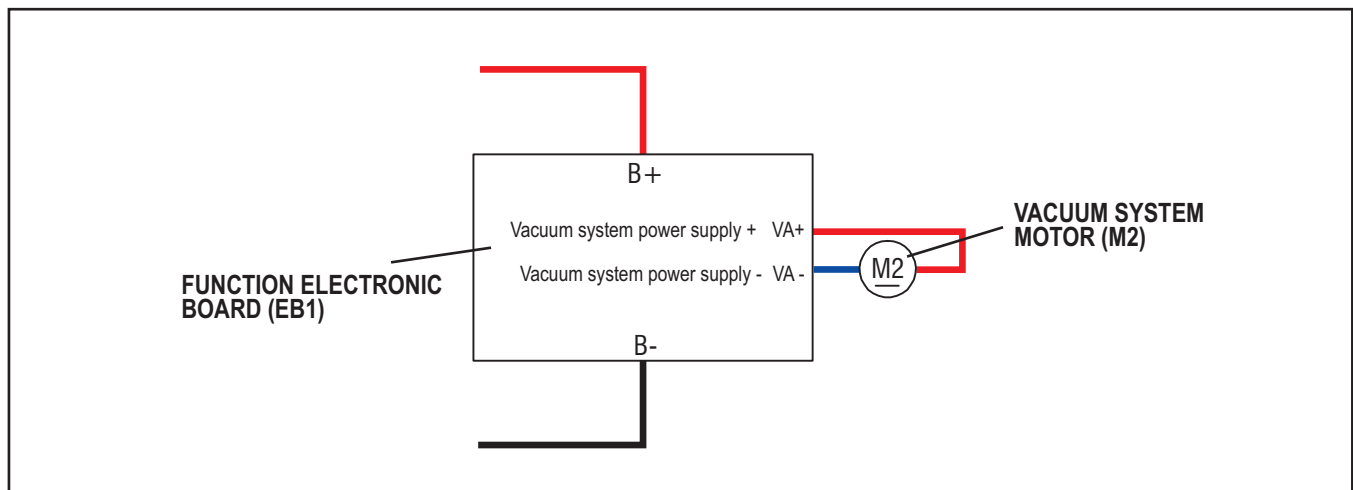


Figure 1

### Component Locations

- Recovery tank
- Recovery tank cover
- Cover gasket
- Vacuum system motor filter
- Recovery water drain hose
- Squeegee vacuum hose
- Vacuum system motor (M2)
- Container with debris collection grid
- Vacuum grid with automatic shut-off float

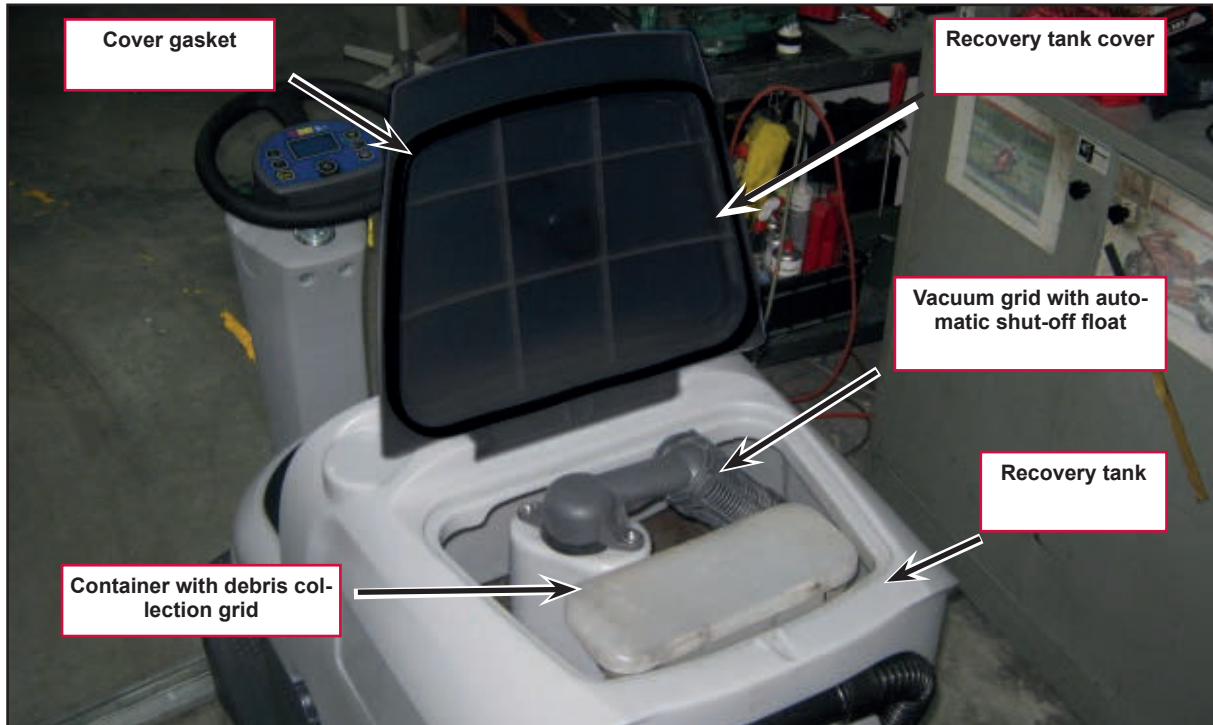


Figure 2

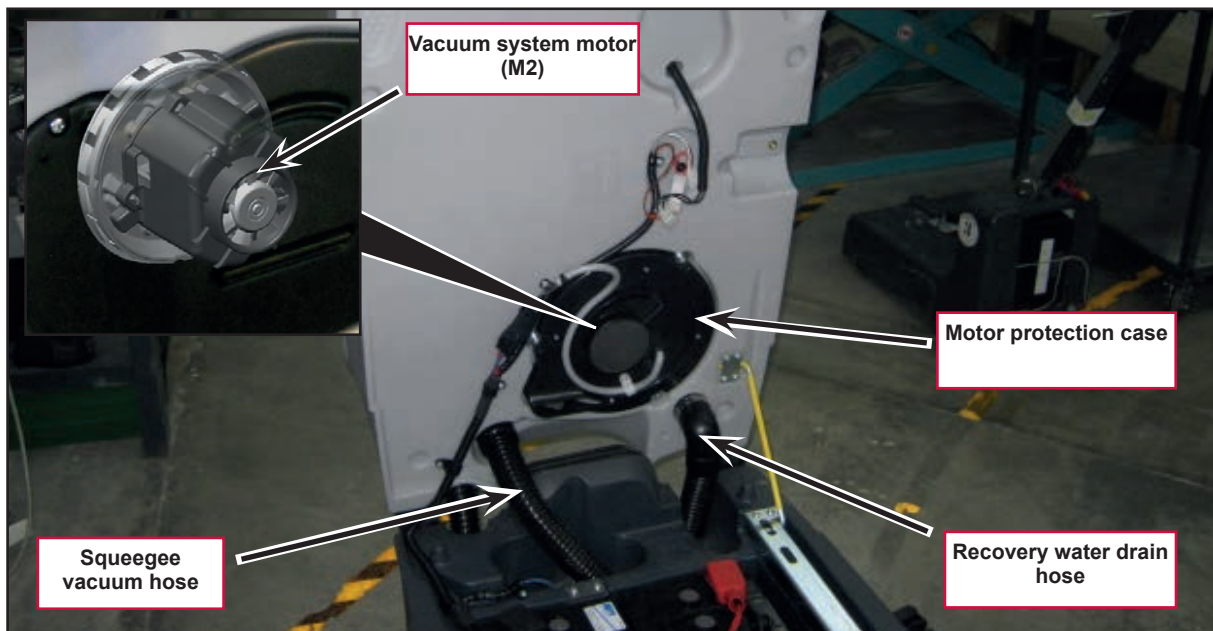


Figure 3

## Maintenance and Adjustments

### Recovery Tank Cleaning

1. Drive the machine to the appointed disposal area.
2. Drain the water from the tank using the drain hose.
3. Lift the recovery tank cover.
4. Clean the vacuum grid (B) (Figure 4), release the fasteners (A), open the grid (B) and recover the float (C), then clean carefully and reinstall.
5. Remove the debris collection tank (D) and open its cover, then clean it carefully.
6. Reinstall it on the vacuum hose.
7. Reinstall the debris collection tank on the rigid tube in the tank.
8. Check the condition of the tank cover gasket (E).



Note:

*The gasket (E) creates the vacuum in the tank that is necessary to vacuum up the recovery water.*

9. If necessary, replace the gasket (E) by removing it from its housing (F). When fitting the new gasket, position the joint (G) in the area shown in the figure.
10. Check that the seating surface (H) of the gasket (E) is in good condition, clean and suitable to form a seal with the gasket itself.
11. Close the cover.

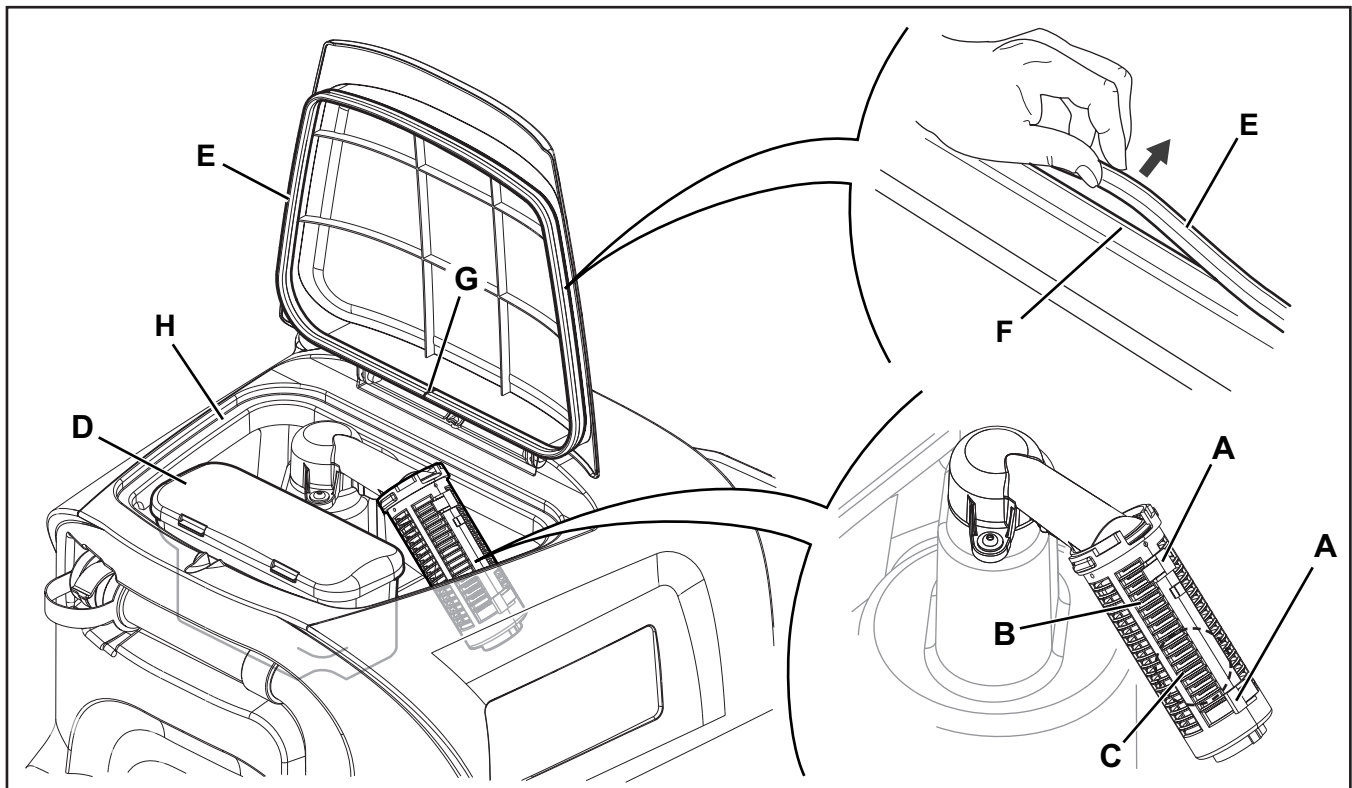


Figure 4

## Troubleshooting


| Trouble  | Possible Causes   | Remedy                  |
|--|---|-------------------------|
| The vacuum system motor will not turn on               | Wiring between function electronic board (EB1) and vacuum system motor (M2) damaged | Repair                  |
|  | Dashboard instrument electronic board (EB4) faulty                                  | Replace                 |
|  | Vacuum system motor faulty  | Check the amperage      |
| Suction of dirty water is insufficient or non-existent | Activation of automatic float shut-off  | Drain the recovery tank |
|  | Debris collection filter dirty  | Clean                   |
|  | Vacuum grid with automatic shut-off float dirty                                     | Clean                   |
|  | Tank cover not correctly positioned   | Adjust                  |
|  | Tank cover gasket damaged or not working correctly                                  | Clean or replace        |
|  | Vacuum system motor container dirty   | Clean                   |
|  | Vacuum seals damaged or not working correctly                                       | Repair or replace       |



## Vacuum System Motor Amperage Test



**Warning!** This procedure must be performed by qualified personnel only.

1. Lift the recovery tank assembly and the driver's seat.
2. Apply the amp clamp (A) to a cable (B) near the vacuum unit (Figure 5).
3. Insert the operator key in its slot.
4. Activate the vacuum by pressing the vacuum button .
5. Check that the vacuum system motor amperage is between 13 and 17A at 24V.
6. If the amperage is higher, remove the vacuum system motor (see the procedure in the Vacuum System Motor Disassembly/Assembly paragraph), and check the condition of all its components to detect and correct the abnormal amperage:

If the above-mentioned procedures do not produce the correct readings for the vacuum system motor amperage, the motor must be replaced.

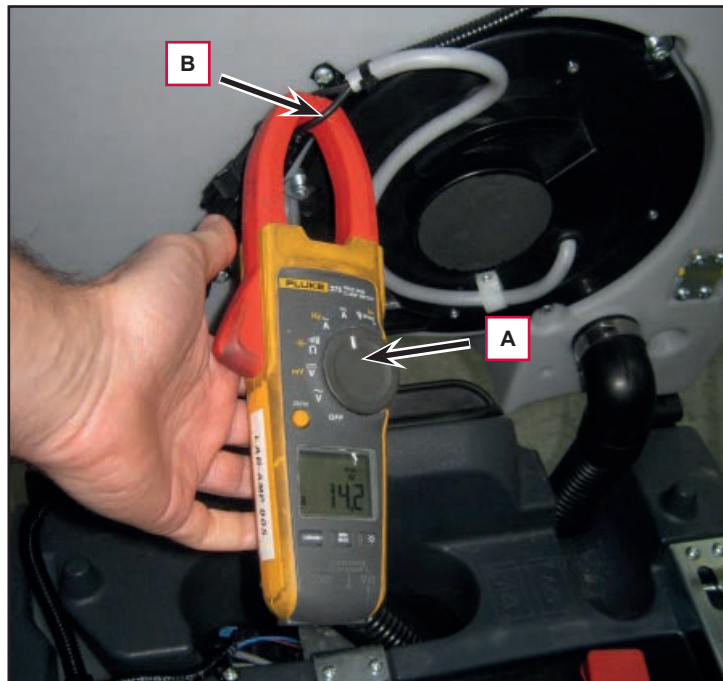


Figure 5

## Removal and Installation

### Vacuum System Motor Unit Disassembly/Assembly

#### Disassembly

1. Remove the operator key.
2. Disconnect the red battery connector.
3. If present, drain the recovery tank, then lift it.
4. Disconnect the connector (A) (Figure 6) and remove the fastening clamp.
5. Unscrew the 3 screws (B) and remove the vacuum system motor unit (C).

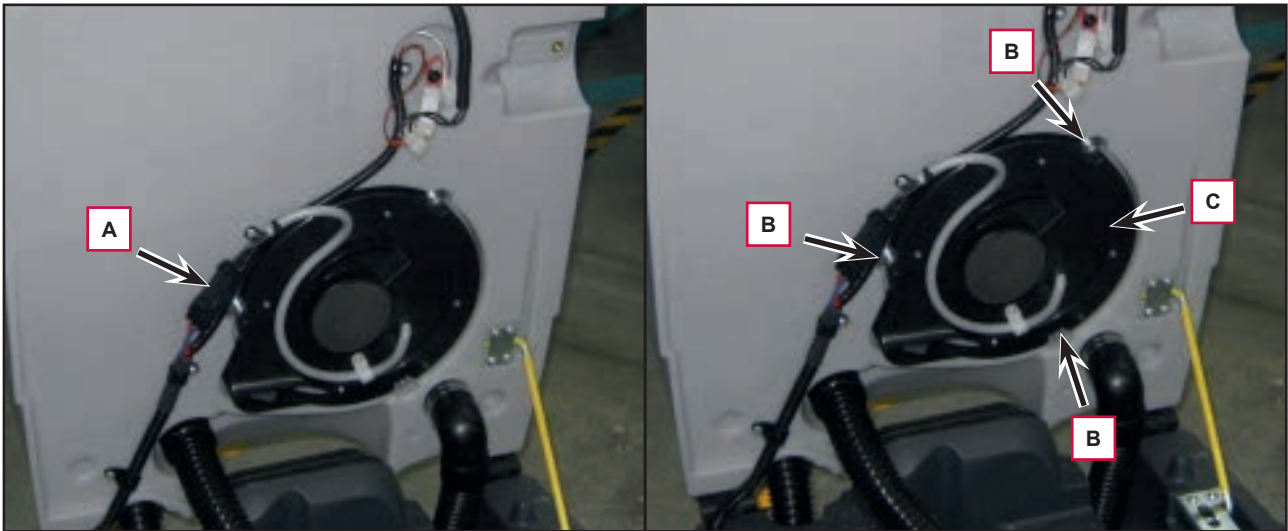


Figure 6

#### Assembly

6. Assemble the components in the reverse order of disassembly.

## Container and Vacuum System Motor Disassembly/Assembly

### Disassembly

1. Disassemble the vacuum system motor unit as shown in the previous paragraph.
2. At the workbench, remove the terminals lock (A) (Figure 7) from the connector (B).
3. With a little screwdriver (C) move the splane lock (D) for disengaging the terminals from the connector.
4. Remove the two terminals (E).
5. Carefully, slightly lift the splane lock (D), previously pressed, to restore it.

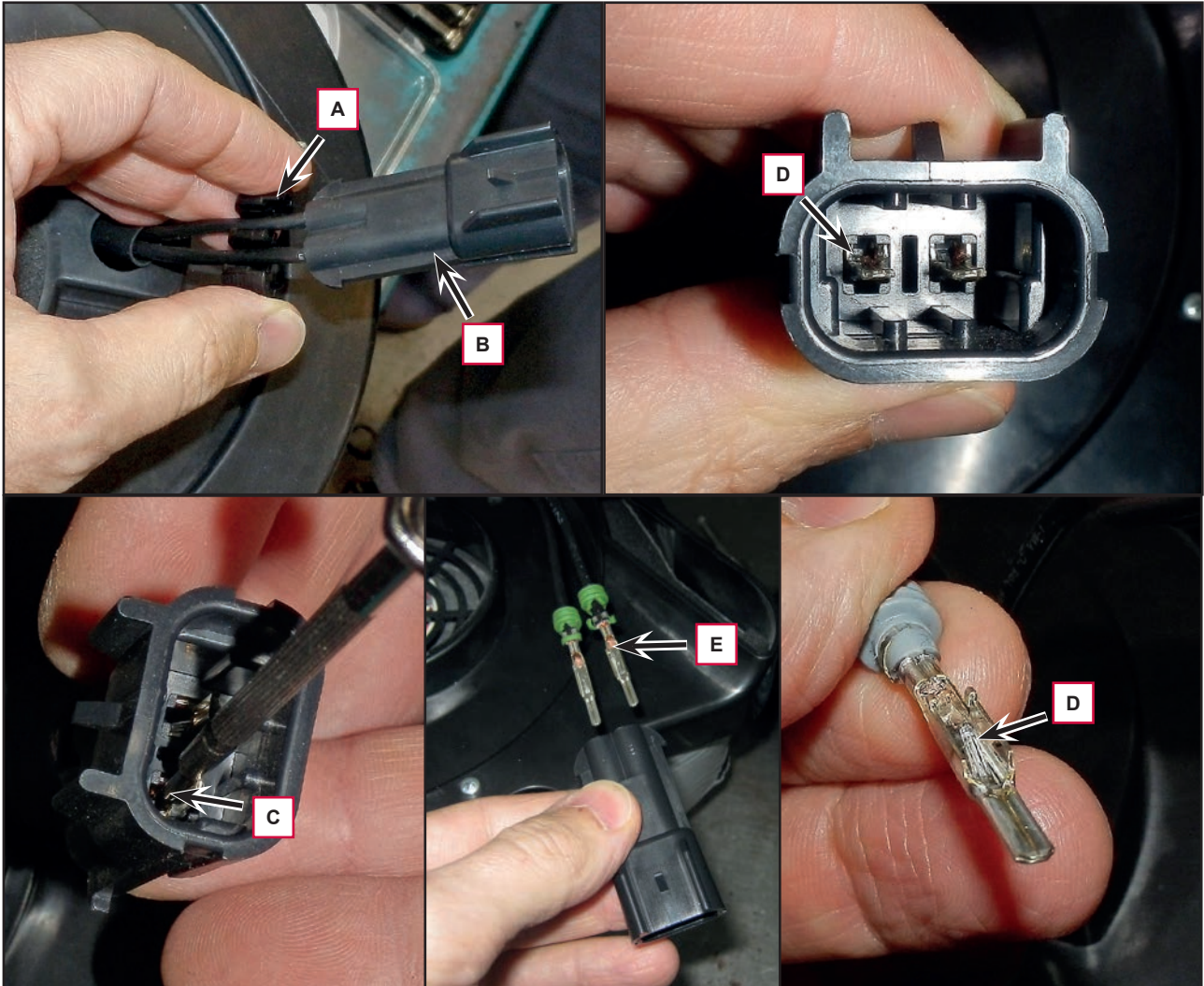


Figure 7

### Container and Vacuum System Motor Disassembly/Assembly (Continues)

6. Remove the clamp (F) (Figure 8).
7. Remove the 4 screws (G) and remove the cover (H).



Figure 8

8. Remove the soundproofing (I) (Figure 9) and (J).
9. Remove the protection (K) to reach the vacuum system motor (L).

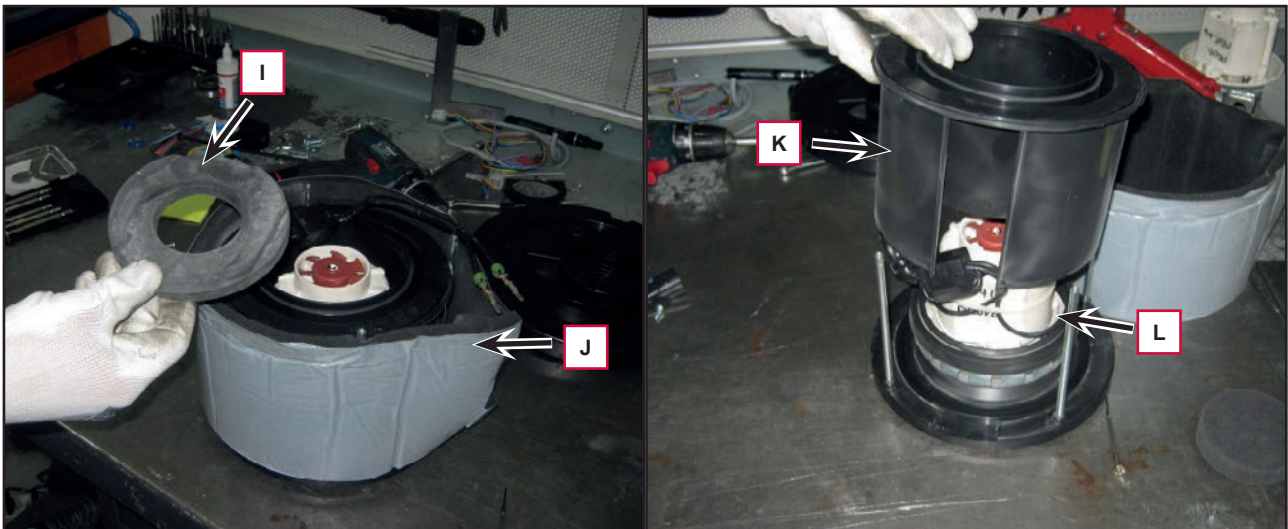


Figure 9

### Container and Vacuum System Motor Disassembly/Assembly (Continues)

10. Clean the inside of the containers from any dirt that has settled and check all gaskets (J) (Figure 10) for wear; replace if necessary.

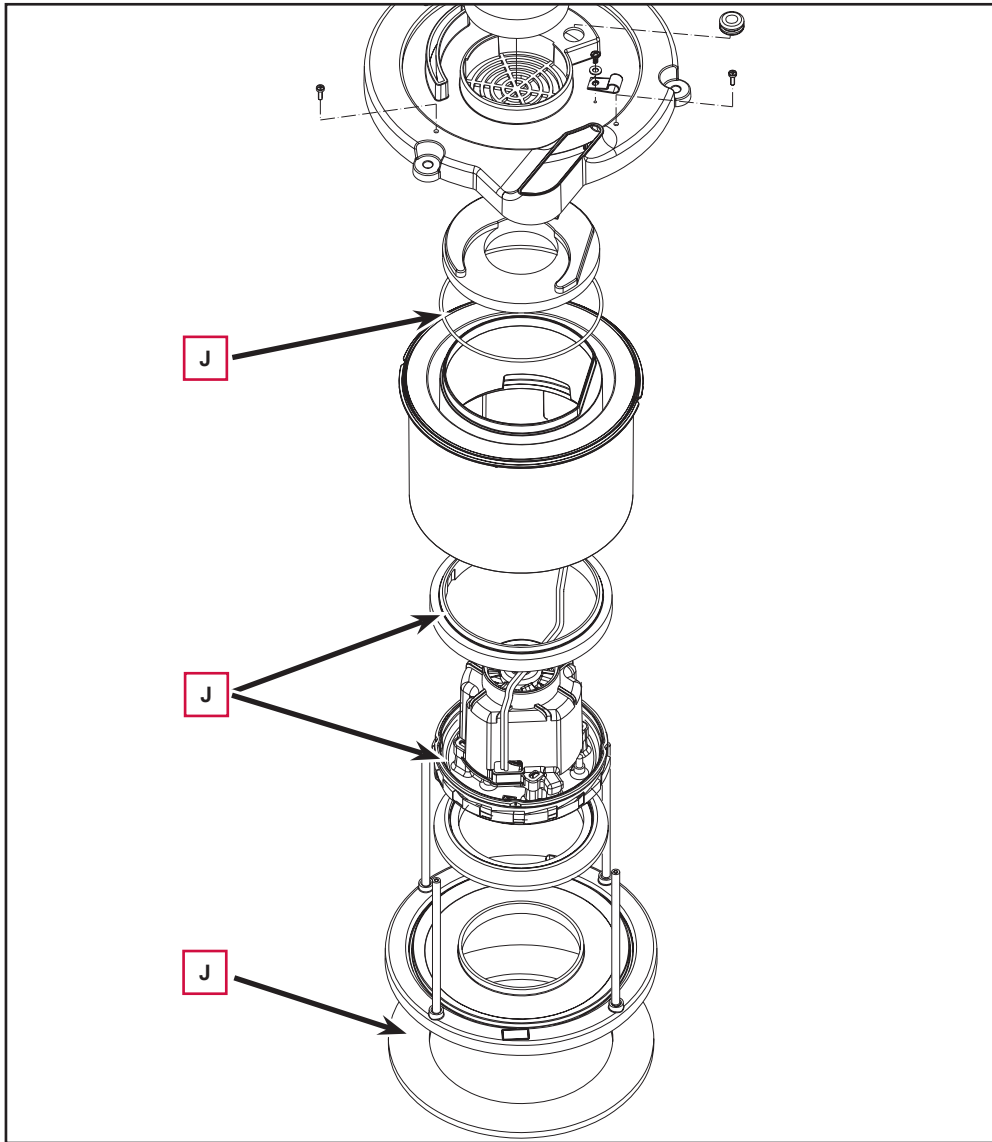


Figure 10

### Assembly

11. Check that all components are reassembled with the correct polarity and orientation.
12. Assemble the components in the reverse order of disassembly.

## Specifications

| Description / Model                |                                | Nilfisk<br>Scubtec R253                           | Nilfisk<br>Scubtec R253 full PKG<br>Clarke RA40 |
|------------------------------------|--------------------------------|---|---|
| Recovery tank capacity             |                                | 18.5 US gal (70 liters)                           |   |
| Vacuum system motor technical data | Power                          | 0.4 hp (310 W)                                    |   |
|                                    | Insulation Class               | H   |   |
|                                    | Voltage                        | VDC 24V   |   |
|                                    | Bearing impeller side          | CW (chemically resistant sealing)                 |   |
|                                    | Insulation materials and wires | "UL" recognized                                   |   |
| Vacuum circuit capacity            |                                | 39 in H <sub>2</sub> O (1000 mm H <sub>2</sub> O) |   |

## Scrub System, Disc

---

### Functional Description

The disc brush system can be started by the operator. The disc brush turn counter-clockwise.

The rotating brush system cleans the surface of the floor. The main component of the brush system is the deck where the brush or the pad-holder with pad suitable for the type of surface to be cleaned is installed. The brush deck is installed on a frame to which the electrical actuator and the four levers for connection to the frame integrated with the brush motor is coupled.

The electrical actuator (M5), with limit microswitches, lifts and lowers the deck. The operating and washing pressure depends on the weight of the deck. The actuator also permits the extra pressure function. Extra pressure is selected via the button on the dashboard. Brush rotation occurs only when the brush motor (M1) is driven by the function electronic board following activation of the accelerator pedal microswitch.

The brush system uses the solution to wash the floor. In case of brush motor overload, a safety system stops the brushes after about one minute of continuous overload.

If the overload takes place when the extra pressure function is on, the system automatically turns the extra pressure function off. If the overload persists, the brush stops.

The overload is detected by monitoring the current flow sum on the brush motor. The current is measured by verifying the voltage drop through the brush system fuse (F1). If the voltage drop reaches the value stored in the parameter “VS2” (default = 70 mV), the display shows the alarm message: WARNING ALARM F2, and if the overload persists, the brush motor will stop following a delay which varies on the basis of the extent of the overload.

To start scrubbing again after a brush stop due to overload, turn the machine off. Then restart the machine by turn the ignition key to “I”.

To work properly, the brush motor (M1) needs the following:

- Driver’s seat microswitch closed
- Brush function on
- Forward pedal pressed
- Battery level not critical, display icon without segments and flashing outline.

### RPM Brush Reduction Function

This function, controlled by the function board, adjusts the brush motor speed and prevents (example: on very smooth floors) the excessive brush rotation speed causes water splashing outside of the cleaning area.

If the brush motor current remains below the parameterized threshold with the RPM parameter, the motor is powered by reduced voltage of 20,0V.

If the brush motor current exceeds the value of parameterized threshold, the motor is supplied at 100% by the battery voltage.

## Wiring Diagram

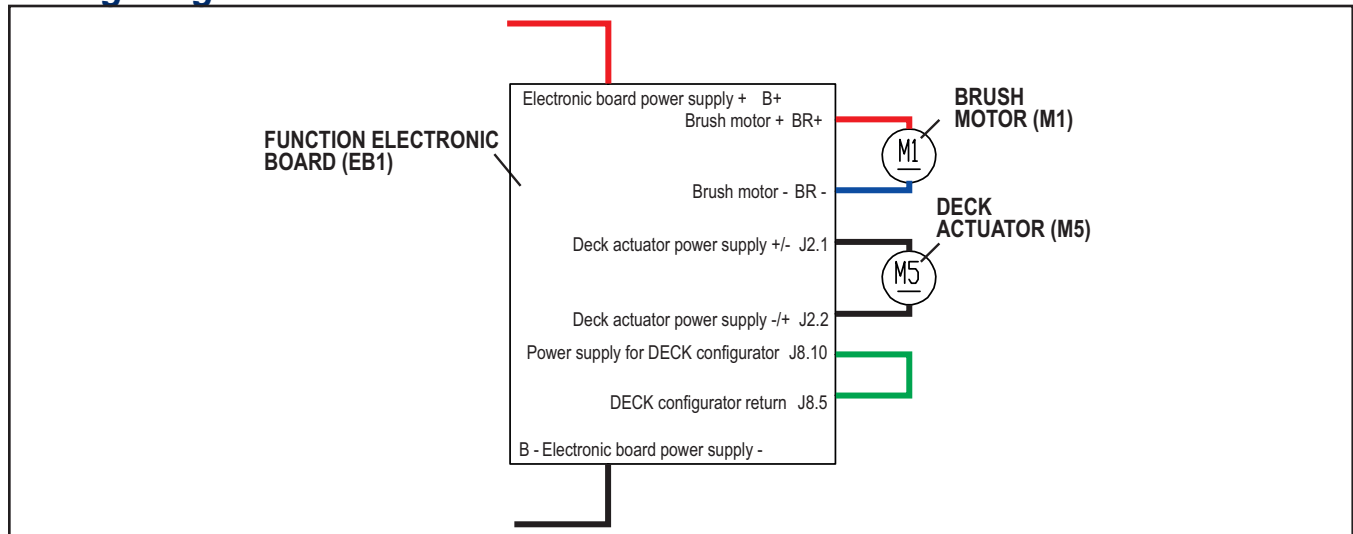


Figure 1

## Brush Deck Actuator System

The brush deck actuator is a new generation actuator developed by SIR and ITALSEA and it is controlled directly by the main board without electromechanical limit switches. ITALSEA patented the system to control the actuator. Basically the system uses deeply measurements of the current flow in the actuator to know its position in real time.

The actuator is mechanically proof of the end of stroke because of it reaches the end of stroke with limited voltage applied and so with a limited speed and force.

The actuator moves and stops in 3 defined positions:

- 1) RETRACTED: fully retracted end of stroke (deck lifted)
- 2) WORK: intermediate position (deck on the floor, normal work condition)
- 3) EXTRAPRESSURE: fully extended end of stroke (deck on the floor with extra pressure given pressing the actuator integrated spring)

The actuator is powered at 50 % PWM (about 12Vdc) near the end of strokes or during the machine switch-on reset feature, otherwise at 100 % PWM (24Vdc)

The machine switch-on reset feature moves the actuator from the position where it was the last time the machine was switched off to the retracted position.

The quotes of the actuator strokes, with a tolerance of ±2mm are: Stroke RETRACTED-WORK = 3.3 in (85 mm), stroke RETRACTED-EXTRAPRESSURE (end to end) = 4.7 in (120 mm).

There are time out limits and amperometric limits related to the different phases of the movement as follow:

| Movement from:             | To:                        | PWM            | AMP limit         | Alarm if AMP limit is reached  | Timeout  |
|----------------------------|----------------------------|----------------|-------------------|--|----------|
| Extrapressure              | Work                       | 100 % (=24Vdc) | 4A per Time>1sec. | Yes  | 7.5 sec. |
| Work                       | Retracted – 0.4 in (10 mm) | 100 % (=24Vdc) | 4A per Time>1sec. | Yes  | 15 sec.  |
| Retracted – 0.4 in (10 mm) | Retracted                  | 50 % (=12Vdc)  | 2A per Time>1sec. | No (The electronic board assumes the actuator reaches the end of stroke) |          |
| Reset (switch on)          |                            | 50 % (=12Vdc)  | 2A per Time>1sec. | No (The electronic board assumes the actuator reaches the end of stroke) | 25 sec.  |



## Component Locations

- Brush motor (M1)
- Disc brush deck
- Deck raising levers
- Brush deck support
- Drive hub

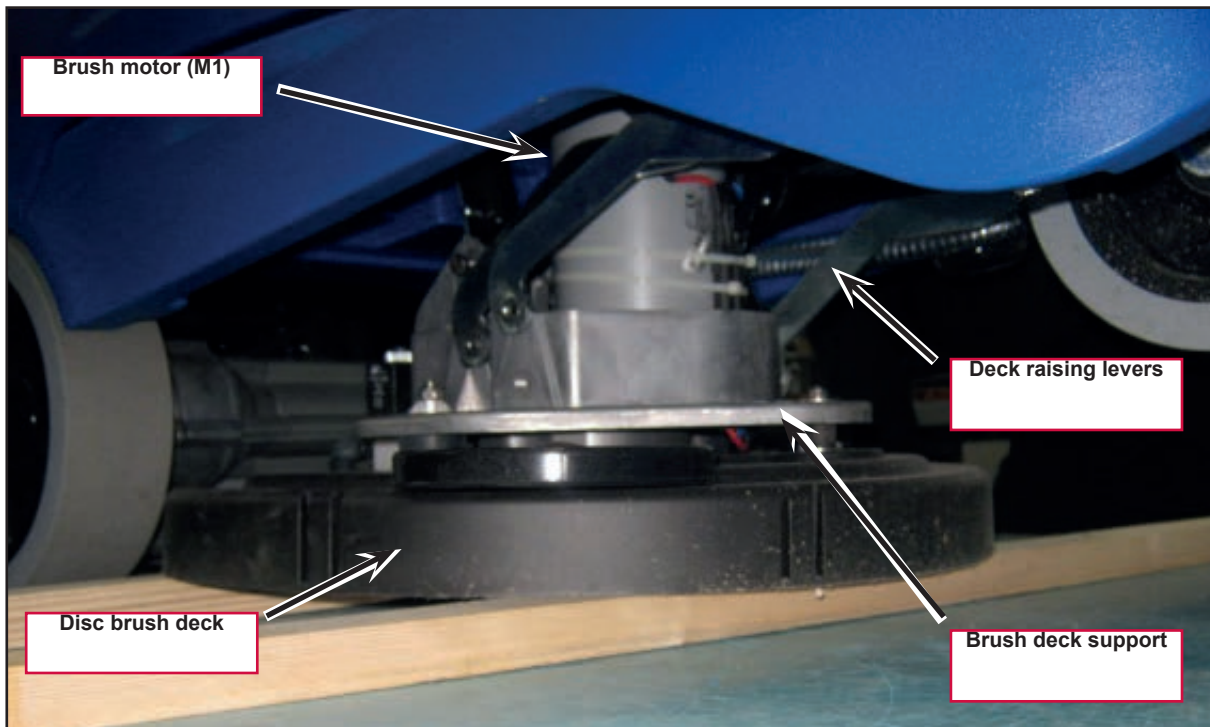


Figure 2

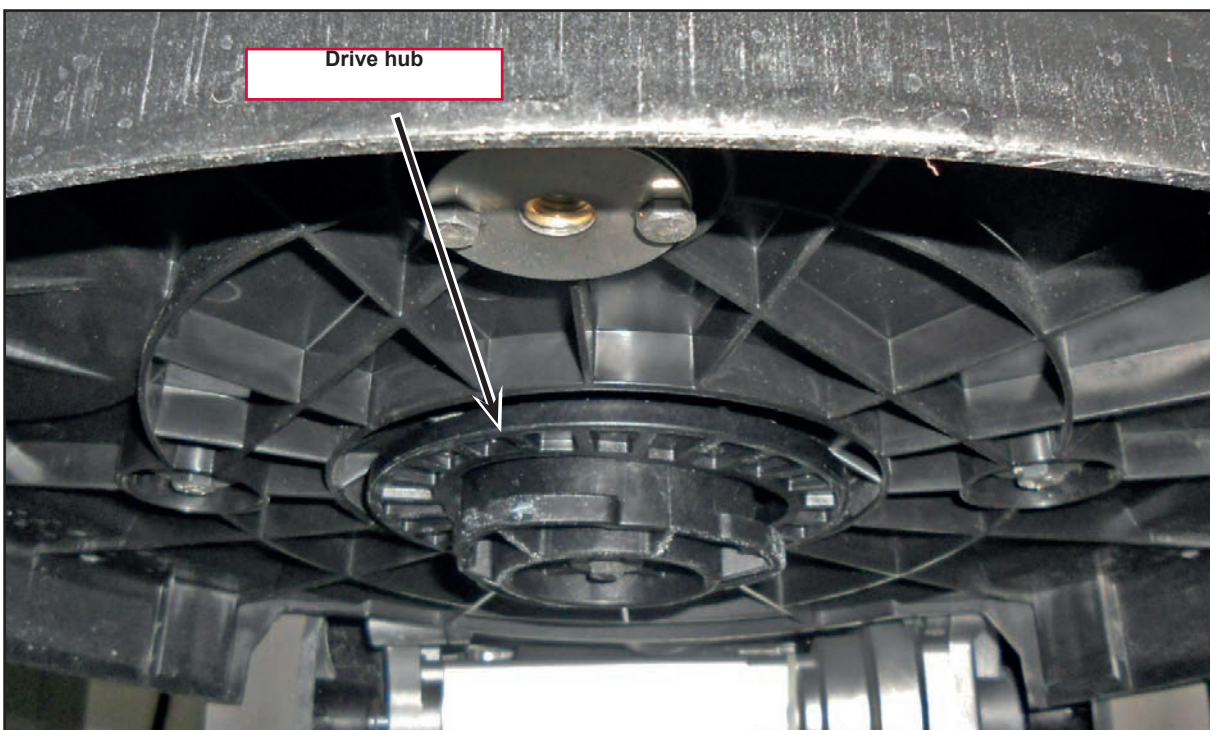


Figure 3

### Component Locations (Continues)

- Brush deck lifting/lowering actuator (M5)
- Function electronic board (EB1)
- Actuator system wiring connection

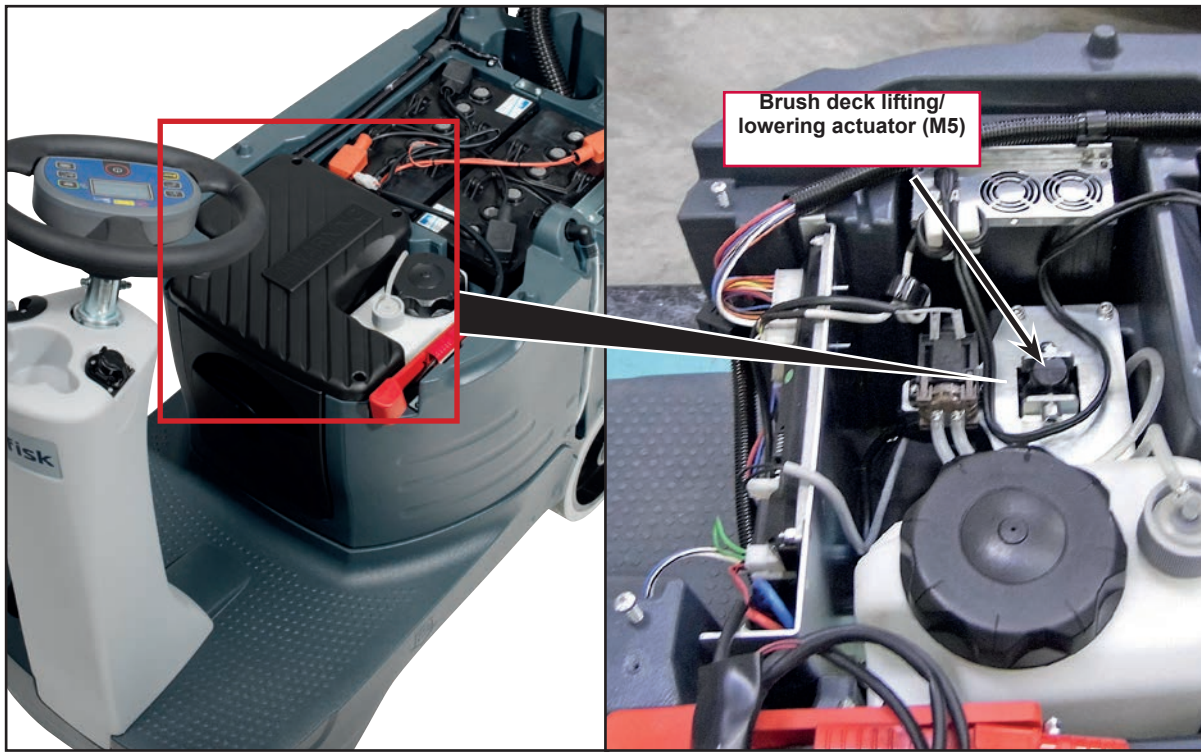


Figure 4

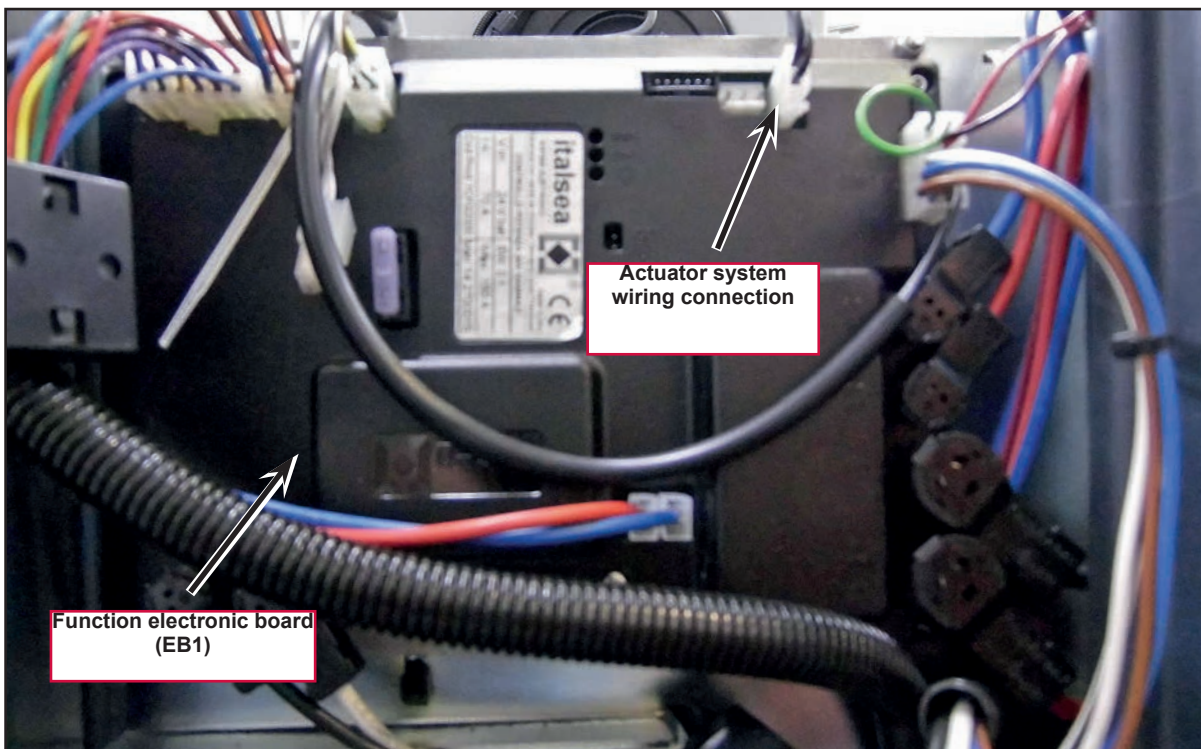




Figure 5

## Maintenance and Adjustments

### Brush Installation/Removal

1. According to the kind of cleaning to be performed, the machine can be equipped either with the brush (A) (Figure 5) or the pad-holder (B) with pad (C) together with the appropriate deck.
2. Place the brush (A) or the pad-holder (B) under the deck.
3. Turn the ignition key to “I”.
4. Press the One-Touch button  to lower the deck onto the brush.
5. To engage the brush, press the drive pedal shortly, if necessary repeat the procedure until the brush is engaged.
6. To remove the brush, lift the deck by pressing the One-Touch button , then manually release the brush from the hub by turning it abruptly in its normal rotation direction.

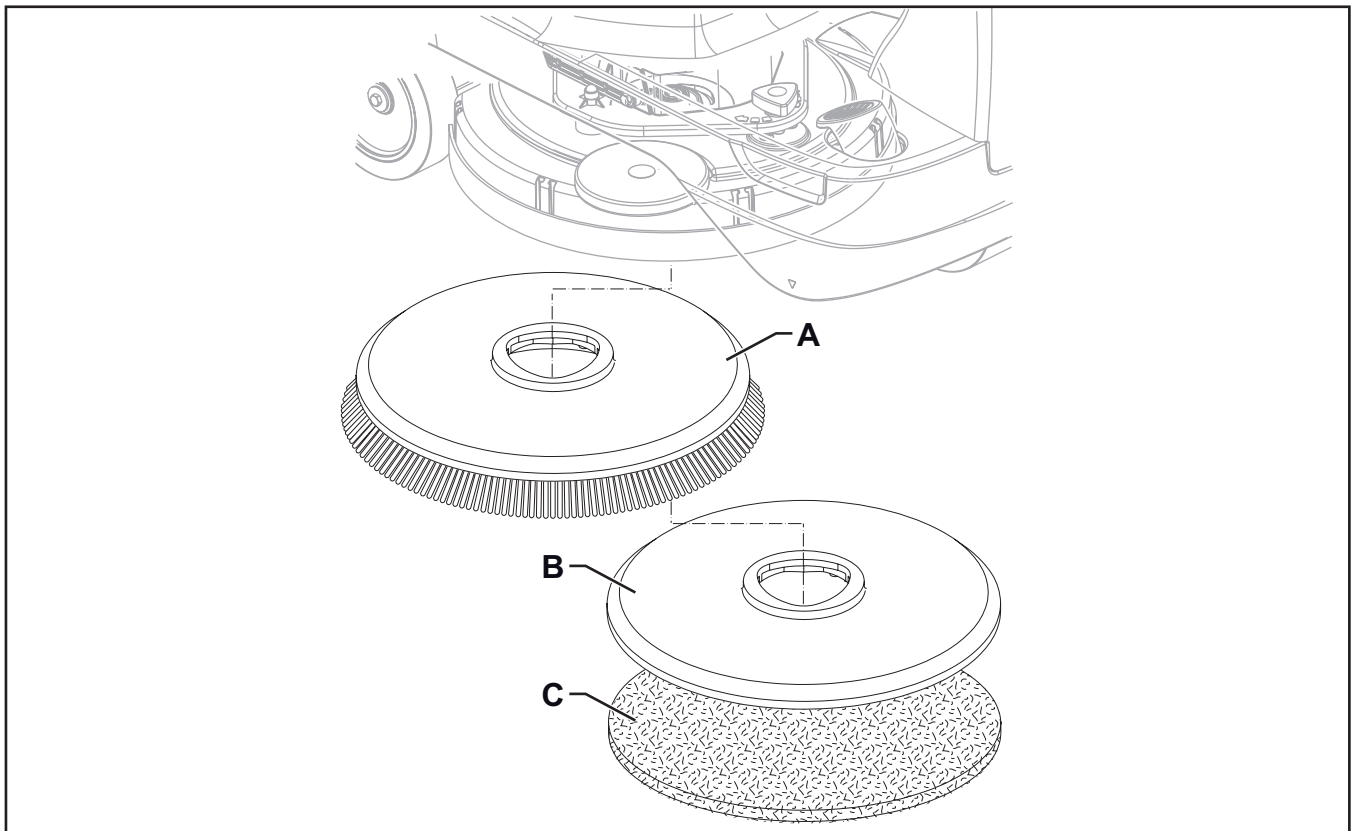


Figure 5


## Troubleshooting

| Trouble                                      | Possible Causes  | Remedy  |
|--|--|---|
| The brush does not clean properly            | The brush is excessively worn  | Replace   |
| One brush does not turn                      |  | See the chapter Control System, Function Electronic Board (EB1) Error Codes                                     |
|  | Brush motor carbon brushes worn  | Replace   |
|  | Presence of bulky debris or string around the brush or between the brush and attachment flange | Remove the brush and clean it   |
|  | Faulty brush motor   | Repair or replace   |
|  | Wiring damaged   | Repair  |
| It is not possible to lift/lower the brush   |  | See the chapter Control System, Function Electronic Board (EB1) Error Codes                                     |
|  | Deck lifting/lowering actuator (M5) broken   | Replace   |
|  | Break in actuator wiring   | Check the connections according to the instructions in the Electrical System chapter, Troubleshooting paragraph |
|  | Function electronic board (EB1) damaged  | Replace   |
| The brush disengagement system does not work | Function electronic board (EB1) faulty   | Replace   |

## Brush Motor Amperage Check




**Warning!** This procedure must be performed by qualified personnel only.

1. Drive the machine on a level floor.
2. Remove the brush.
3. Lift the recovery tank assembly and the driver's seat.
4. Disassemble the electronic component compartment cover and the function electronic board panel.
5. Disconnect the drive system connector (A) (Figure 6) on the function electronic board (B) to disable machine movement.
6. Turn the ignition key to "I".
7. Press the One-Touch button  to lower the brush deck.
8. Apply the amp clamp (C) to an electrical cable (D) of the brush motor.



**Note:** Use a jumper wire to disable the driver's seat sensor.

9. Activate the brush by pressing the accelerator pedal, then check that the brush motor amperage is between 3 and 4A at 20V(\*).
10. Deactivate the brush by releasing the accelerator pedal and raise the brush deck by pressing the One-Touch button .
11. Remove the amp clamp (C).
12. If the amperage is higher, perform the following procedures to detect and correct the abnormal amperage:
  - Check the brush motor carbon brushes.
  - Remove the brush motor then check the condition of its components.
13. If the above-mentioned procedures do not lead to a correct amperage, it is necessary to replace the brush motor.

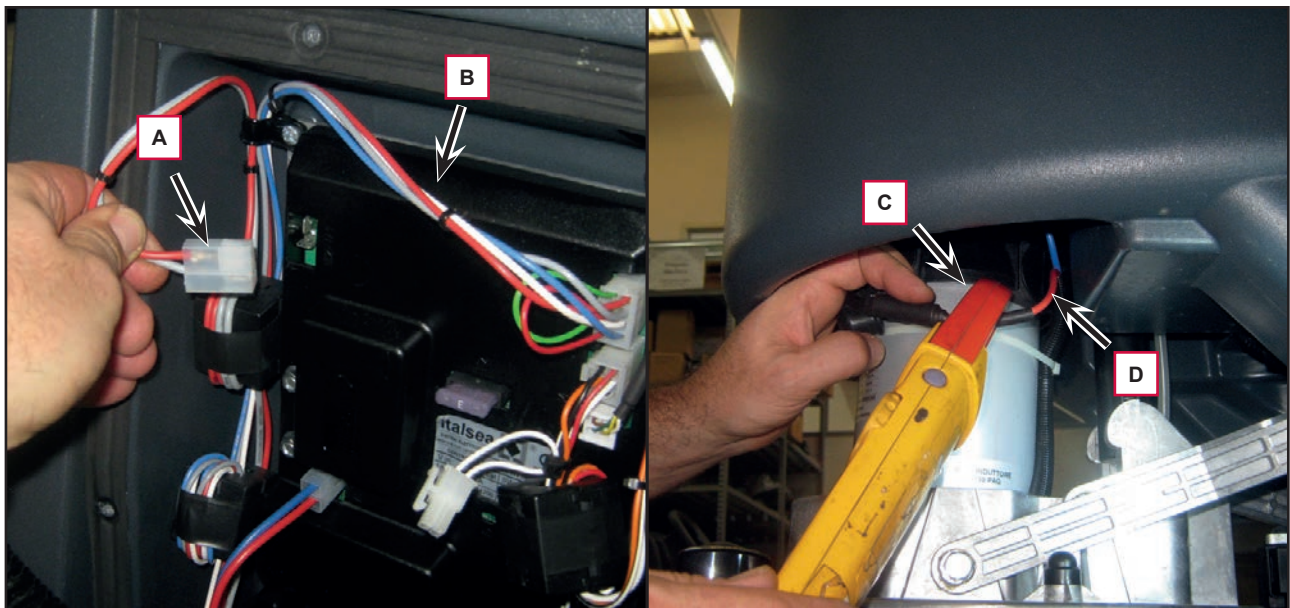



Figure 6

(\*) Voltage value supplied by the electronic board to the brush gearmotor when the gearmotor amperage is less than the value of the RPM parameter.

## Removal and Installation

### Brush Deck Disassembly/Assembly

#### Disassembly

1. Drive the machine on a level floor or on a hoisting system to facilitate the disassembly procedures.
2. Remove the brush.
3. Place two wooden shims (B, Figure 7), at least 4 cm thick, under the brush deck (A).
4. Turn the ignition key to “I”.
5. Lower the brush deck by pressing the One-Touch button , then press it again and hold it for more than 1 second to activate the brush extra pressure function.
6. Lift the recovery tank assembly and the driver’s seat.
7. Switch off the machine and disconnect the battery connector.
8. Disassemble the electronic component compartment cover and the function electronic board panel.
9. Remove the 4 screws (C) and remove the actuator plate (D).

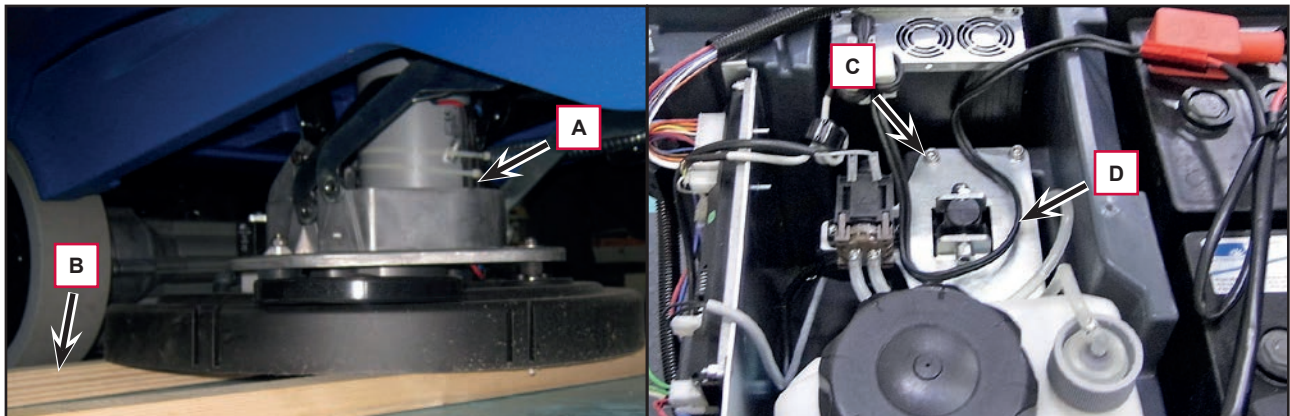


Figure 7

10. Remove the screw (E, Figure 8) and release the actuator lower pin (F).
11. Disconnect the electrical connection (G) and the detergent hose (H) from the solenoid valve (I).

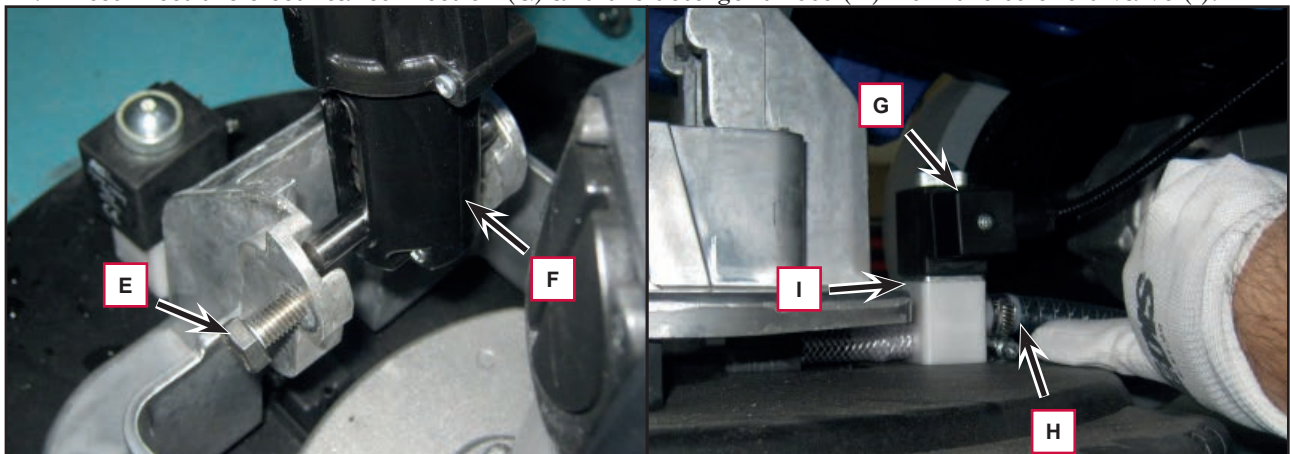


Figure 8

## Brush Deck Disassembly/Assembly (Continues)



**Warning!** To easily remove the brush deck, lift the machine body at the front side as shown (L, Figure 9). Use extreme caution and follow the safety regulations using proper equipment or safety fixed supports suitable for the purpose.

12. Remove the 4 screws (J, Figure 9) from the raising levers (K).
13. Lift the machine body (L) and disconnect the electrical wiring harness (M) from the brush motor, then remove the brush deck (N) under the machine body.

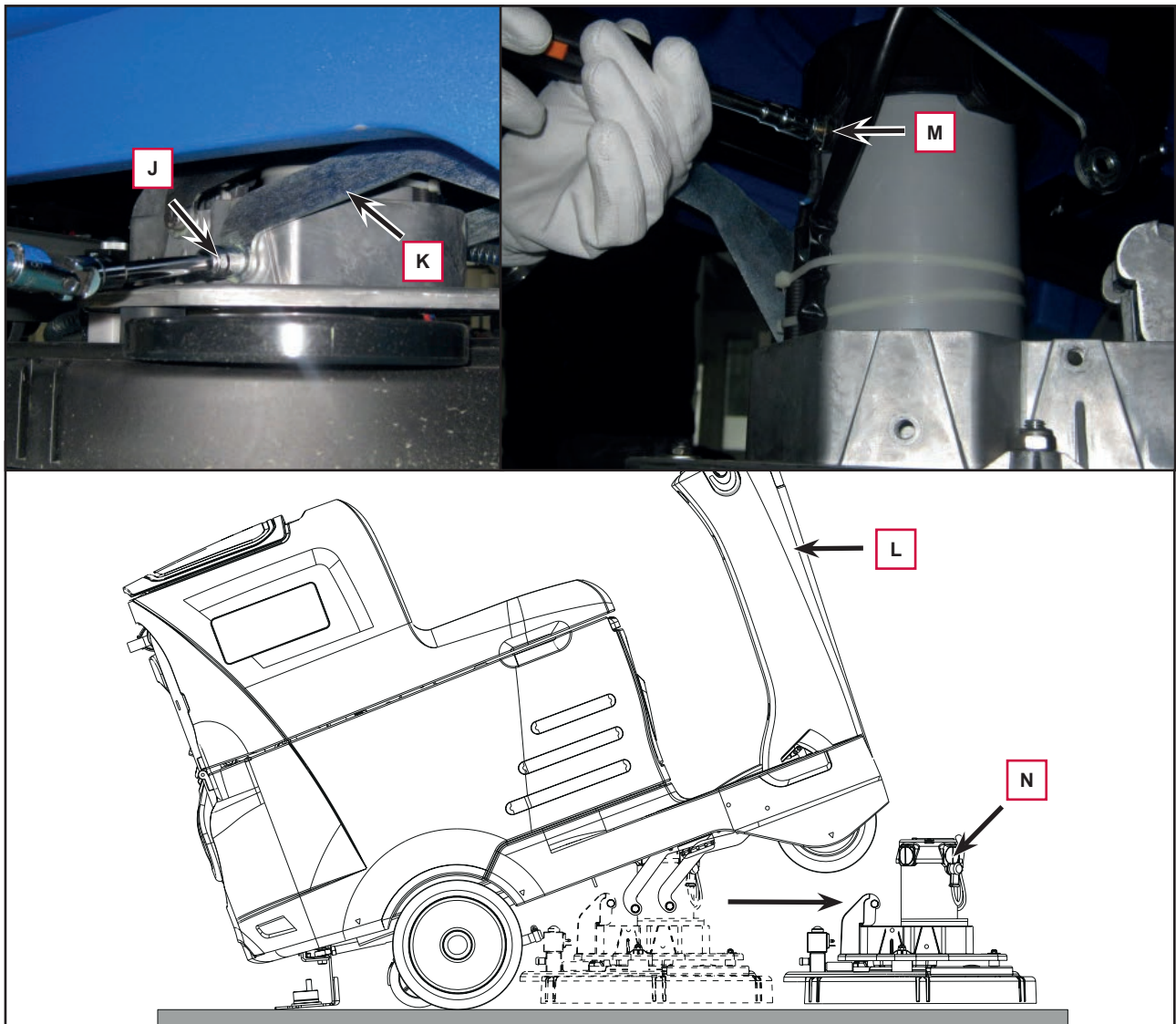


Figure 9

### Assembly

14. Assemble the components in the opposite order they were removed in, ensuring the brush motor power supply cable polarities are correct.

## Checking/Replacing Brush Motor Carbon Brushes

### Check

1. Remove the brush deck.
2. Remove any dust and dirt from around the brush motor carbon brushes.
3. Remove the four protective covers (A) (Figure 10) by disconnecting the clips.
4. Remove the carbon brush nuts (B) with the lead-in wires.
5. Disengage the tabs (C) and remove the carbon brushes (D).
6. Check the carbon brushes (D) for wear. The carbon brushes are worn out when:
  - They do not make sufficient contact with the armature of the brush motor due to their wear
  - When their contact surface is not intact
  - When the residual stroke is below 0.12 in (3 mm)
  - When the thrust spring etc. is broken
7. Replace the carbon brushes as an assembly.

### Reassembly

8. Assemble the components in the reverse order of disassembly.

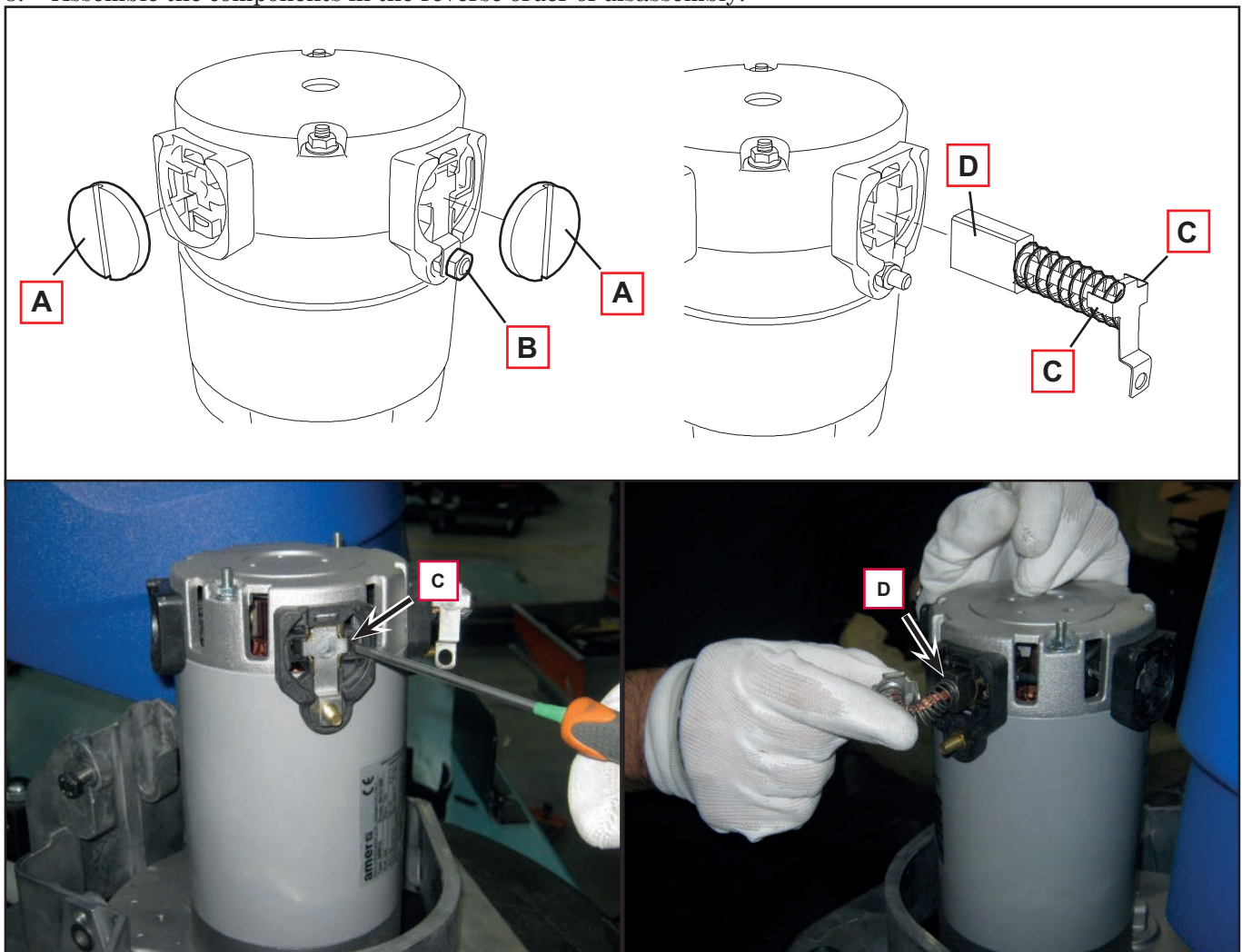


Figure 10



## Brush Motor Disassembly/Assembly

### Disassembly

1. Remove the brush deck.
2. At the workbench, remove the screw (A) (Figure 11) of the brush motor.
3. Use a puller to remove the brush hub (B).
4. Remove the screws (C).
5. Remove the brush motor (D).
6. Recover the key (E).

### Assembly

7. Assemble the components in the reverse order of disassembly.



Note:

For further information on deck components see the Spare Parts List.

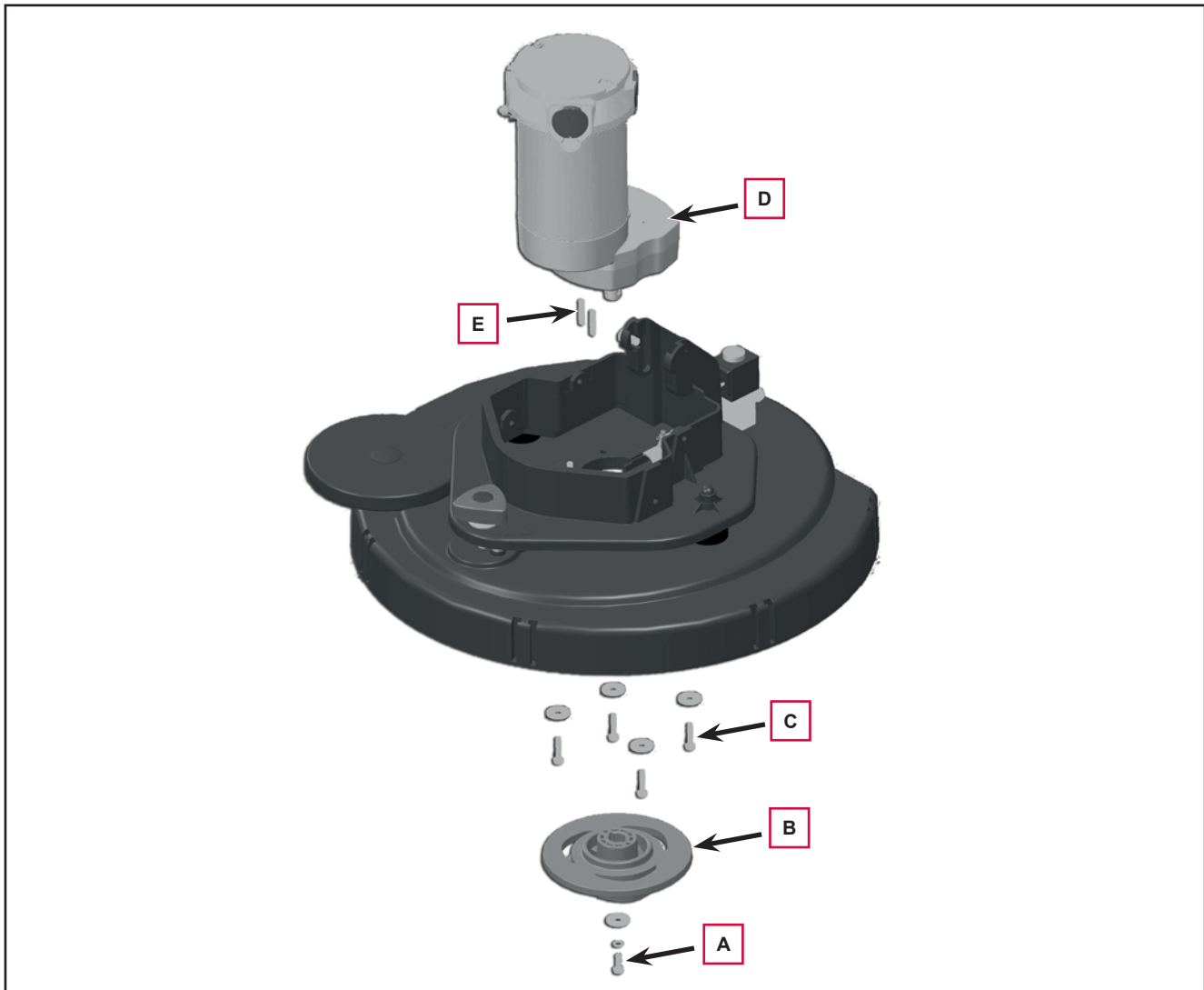



Figure 11

## Brush Deck Actuator Disassembly/Assembly

### Disassembly

1. Drive the machine on a level floor.
2. Place two wooden shims (B, Figure 12), at least 4 cm thick, under the brush deck (A).
3. Turn the ignition key to “T”.
4. Lower the brush deck by pressing the One-Touch button , then press it again and hold it for more than 1 second to activate the brush extra pressure function.
5. Lift the recovery tank assembly and the driver’s seat.
6. Switch off the machine and disconnect the battery connector.
7. Disassemble the electronic component compartment cover and the function electronic board panel.
8. Disconnect the actuator connection (C) on the function electronic board (D).
9. Remove the 4 screws (E) and remove the actuator plate (F).

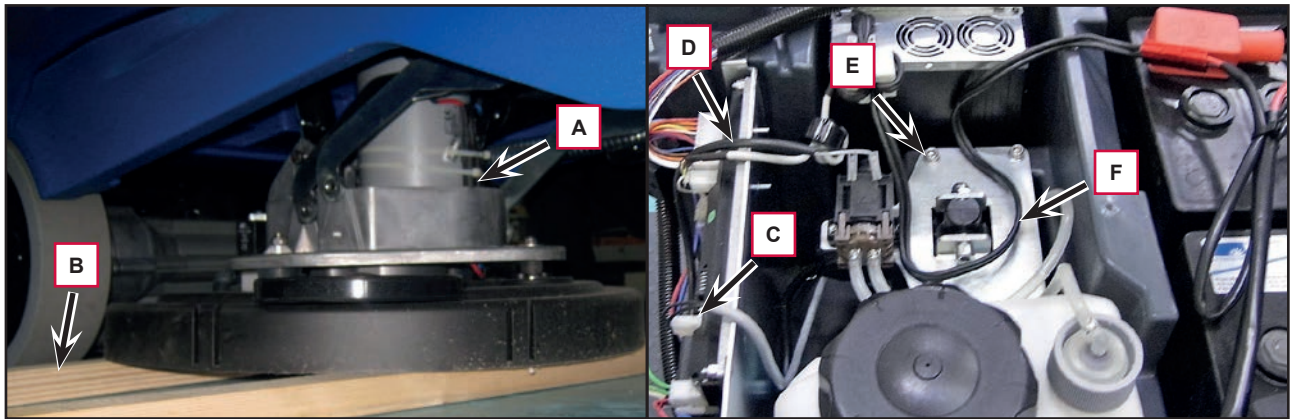


Figure 12

10. Remove the screw (G, Figure 13) and release the actuator lower pin (H).
11. Disassemble the actuator (H) by unscrewing the upper pin (I).

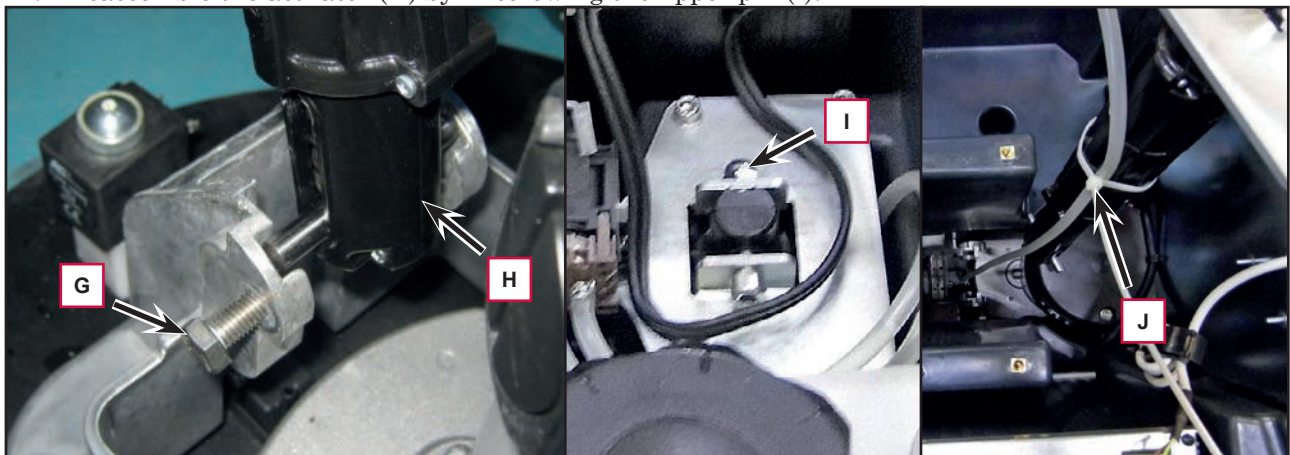


Figure 13

### Assembly

12. Assemble the components in the reverse order of disassembly, by paying attention to the detergent hose (J).

## Specifications

| Description / Model                         |                            | Nilfisk<br>Scubtec R253   | Nilfisk<br>Scubtec R253 full PKG<br>Clarke RA40 |
|---|----------------------------|---------------------------|---|
| Cleaning width                              |                            | 21 in (530 mm)            |   |
| Brush/pad diameter                          |                            | 21 in (530 / 508 mm)      |   |
| Brush pressure                              |                            | 33 lb (15 kg)             |   |
| Brush pressure (extra pressure on)          |                            | 66 lb (30 kg)             |   |
| Brush deck right/left offset                |                            | 65 / 15 mm (2.5 / 0.6 in) |   |
| Brush distance from the floor (when lifted) |                            | 1.6 in (40 mm)            |   |
| Brush motor power                           |                            | 0.6 hp (450 W)            |   |
| Brush rotation speed                        |                            | 155 rpm                   |   |
| Protection class                            |                            | IP 20                     |   |
| Insulation class                            |                            | F                         |   |
| Actuator technical data                     | Spring load                | 105 ÷ 155 N               |   |
|   | Regulated travel           | 2.6 in (66 mm)            |   |
|   | Total travel               | 3.6 in (98 mm)            |   |
|   | Maximum speed              | 16 mm/s                   |   |
|   | Voltage                    | 24V                       |   |
|   | No load current Amps max   | 0,5 A                     |   |
|   | Full load current Amps max | 3 A                       |   |
|   | Stall Amps                 | 5,5 A                     |   |
|   | Protection class           | IP 44                     |   |
|   | Insulation class           | A                         |   |

## Solution System

---

### Functional Description

The solution system supplies water and detergent to the brush when cleaning the floor. The solution tank is also the main machine body. There is a manual valve on the left side of the tank, just under the rear wheel, to close the water supply whenever maintenance must be performed on the machine. The solution flows from the tank to the valve, through the filter and solenoid valve (EV1) and then to the brush deck.

The detergent pump (M4), present only on Chemical Mixing System, controls the flow of detergent from the Chemical Mixing System tank which is then transported to the flow in the main tube just before the solution enters the brush deck.

The Chemical Mixing System can be selected with the specific detergent percentage adjustment button



The quantity of detergent is defined by the operator via the buttons on the dashboard instrument electronic board (EB4).

Solution flow levels 1, 2 and 3 regulate the flow of solution on the basis of the machine speed so as to keep the quantity of solution dispensed per square metre of floor treated constant (for further details and modifications, see the corresponding paragraph in the chapter Control System).

Located centrally, below the solution tank, there is also a hole for draining any liquid in the battery compartment.

The solution flow is regulated by various timed ON / OFF cycles, according to:

- Water flow rate adjustment (0 - 4)
- Solution tank level

Both the solenoid valve and detergent pump (when the Chemical Mixing System is enabled) follow the same timings.

The solenoid valve and detergent pump operate only with the following inputs/conditions:

- Driver's seat microswitch closed
- Brush function on
- Forward pedal pressed
- Battery level not critical, display icon without segments and flashing outline.

### Water Level Sensor Operation

The water level sensor (SW1) is positioned about half the height of the solution tank so as to provide the information to the electronic system on the level of water present in the tank (more than half, less than half). Through this information the times of opening of the solenoid valve (EV1) and the detergent pump (M4) are adjusted to maintain this flow more constant (Figure 1).

The water level sensor is capacitive with NPN output (output 0 Volt with water, floating without water).

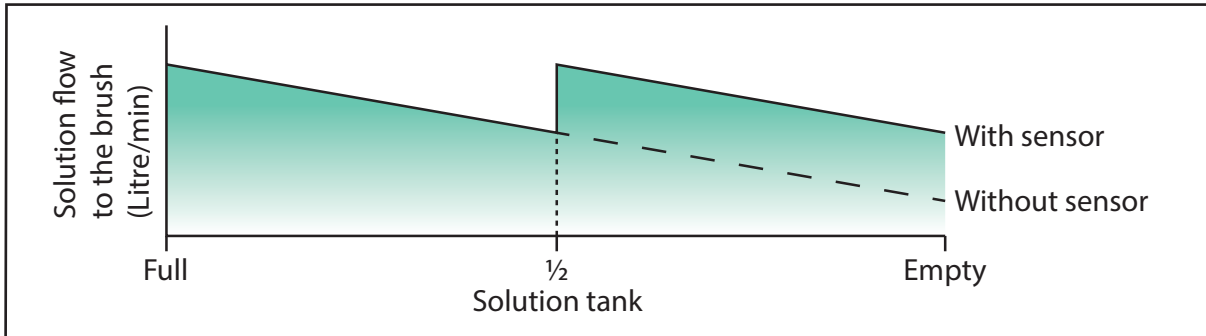


Figura 1

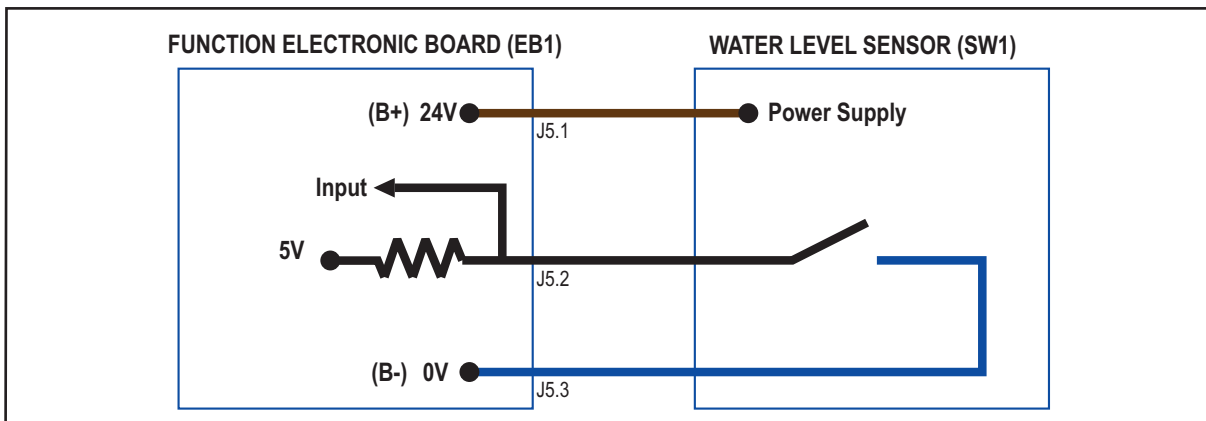


Figura 2

### Wiring Diagram

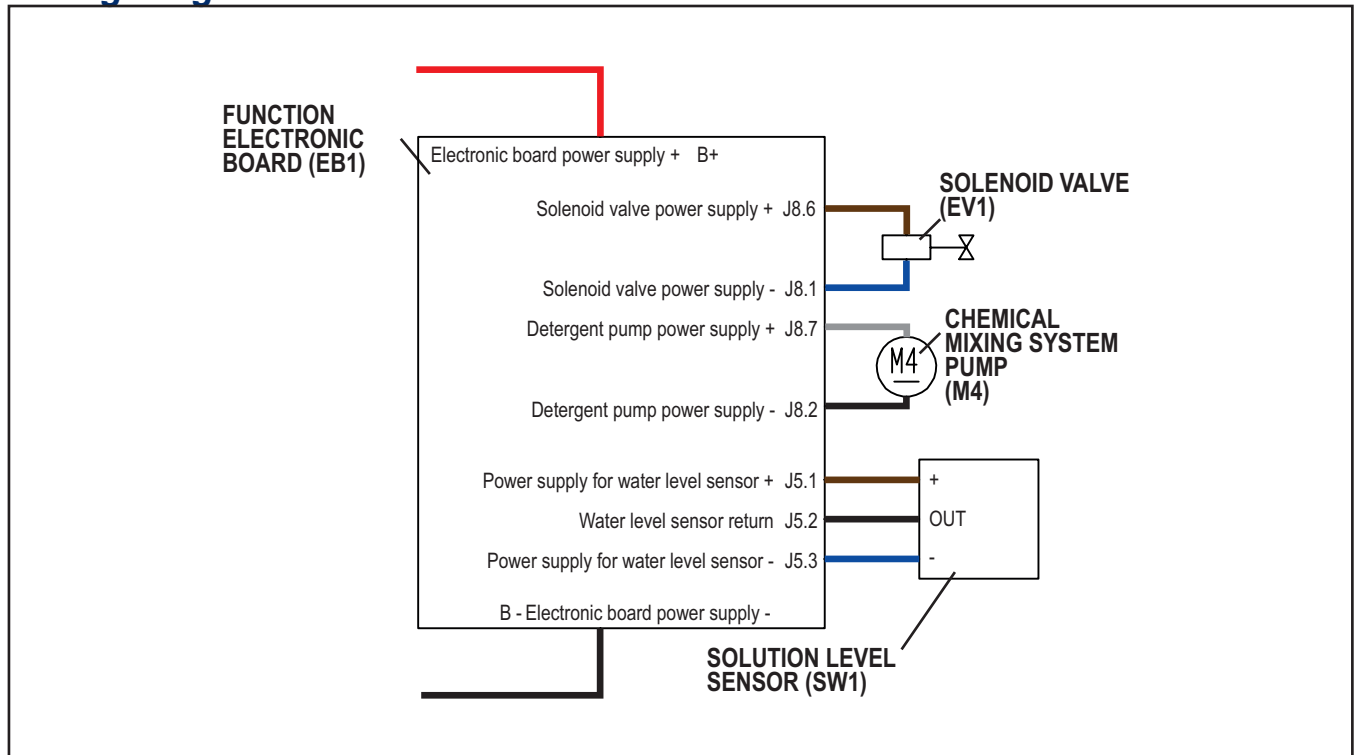


Figure 3

## Component Locations

- Solution tank
- Solution tank filler plug
- Water removable filler hose
- Solution drain and level check hose
- Solution valve
- Solution filter
- Solenoid valve (EV1)

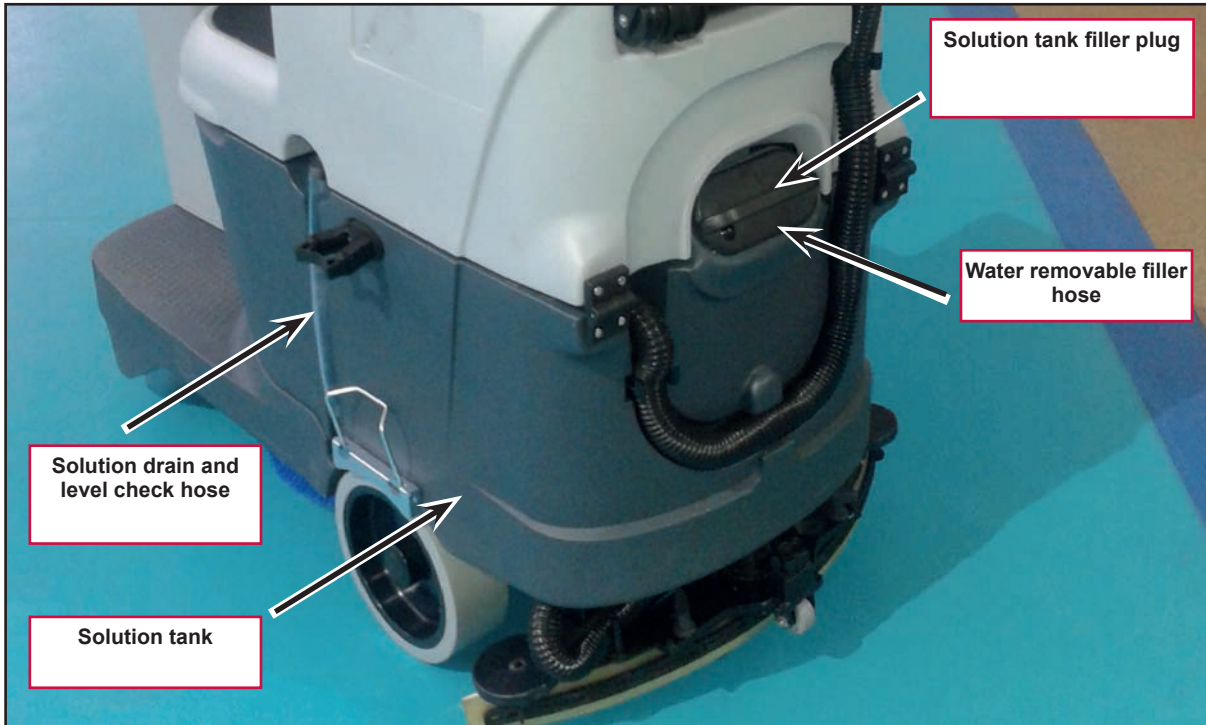


Figure 4

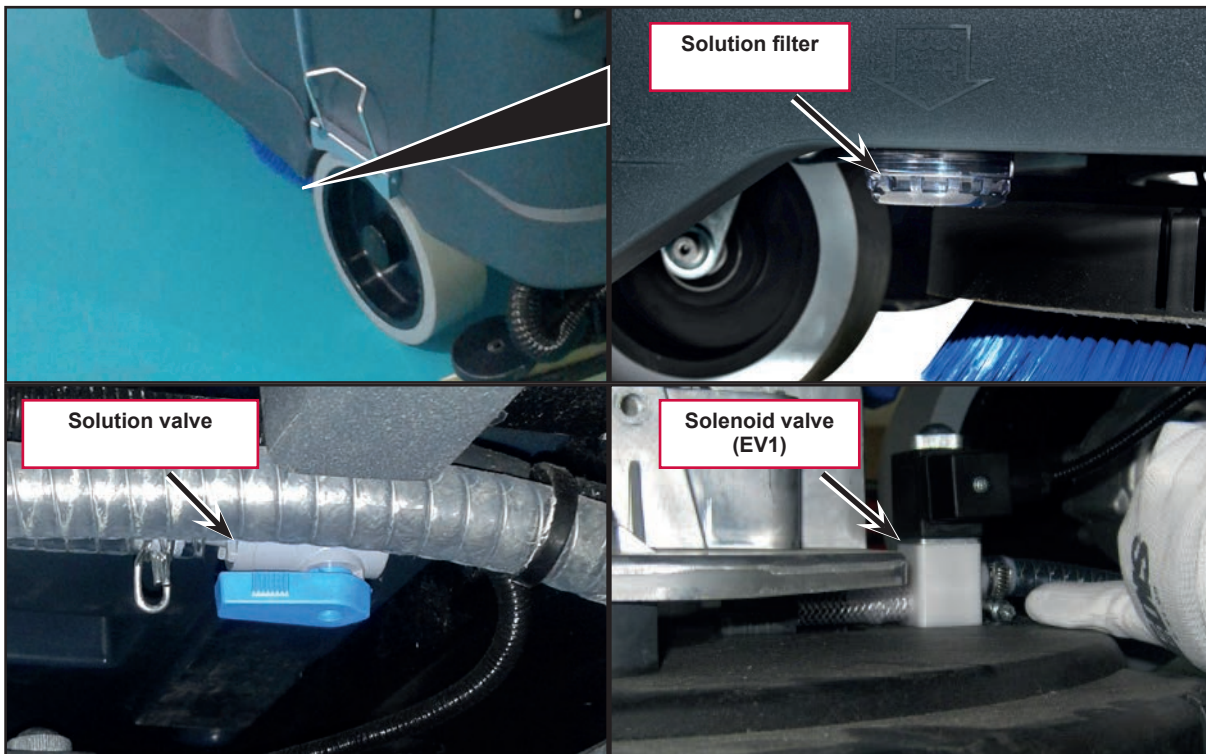


Figure 5

### Component Locations (Continues)

- Chemical Mixing System detergent tank
- Plug with detergent supply hose
- Chemical Mixing System detergent pump (M4)
- Water level sensor (S1)
- Battery compartment liquid drain hole

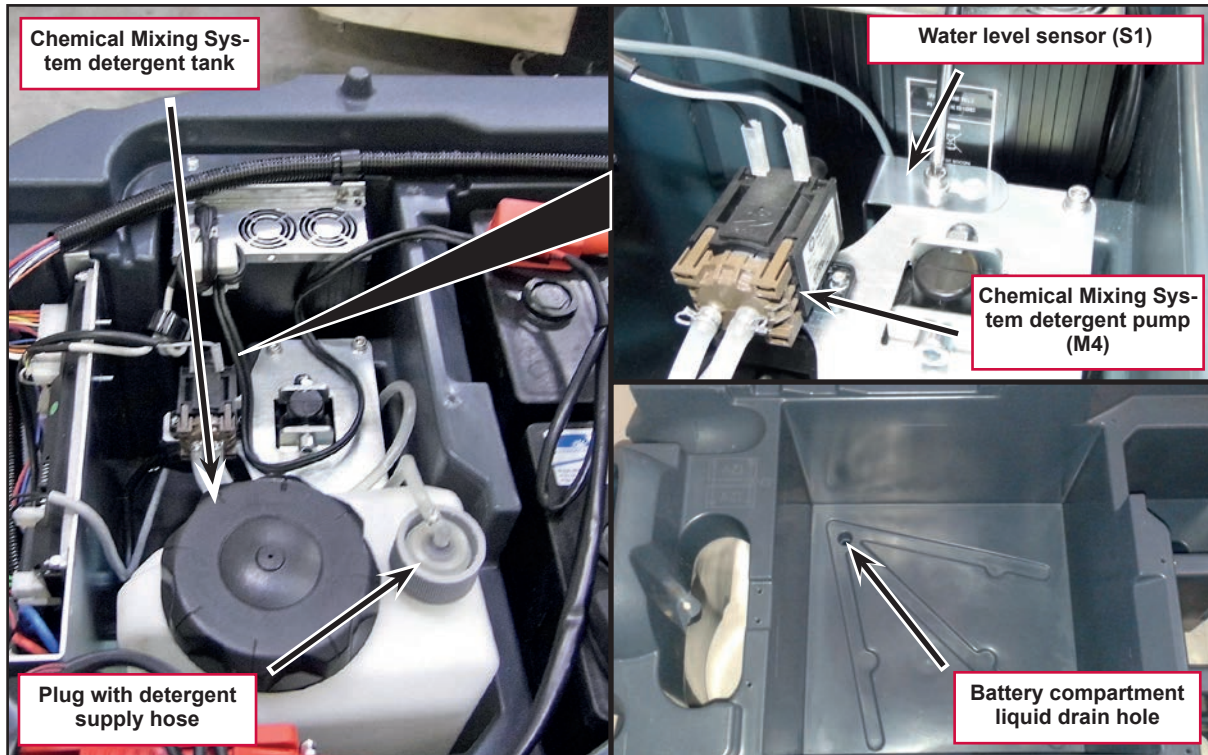


Figure 6



## Maintenance and Adjustments

### Cleaning the Solution Tank and Filter

1. Drive the machine on a level floor.
2. Ensure that the machine is off and the operator key has been removed.
3. Close the solution tank valve.
4. Remove the transparent cover (A, Figure 7), retrieve the gasket (B), then remove the filter strainer (C).
5. Wash and rinse them with water, then refit them carefully onto the filter support (D).
6. Open the solution tank valve.

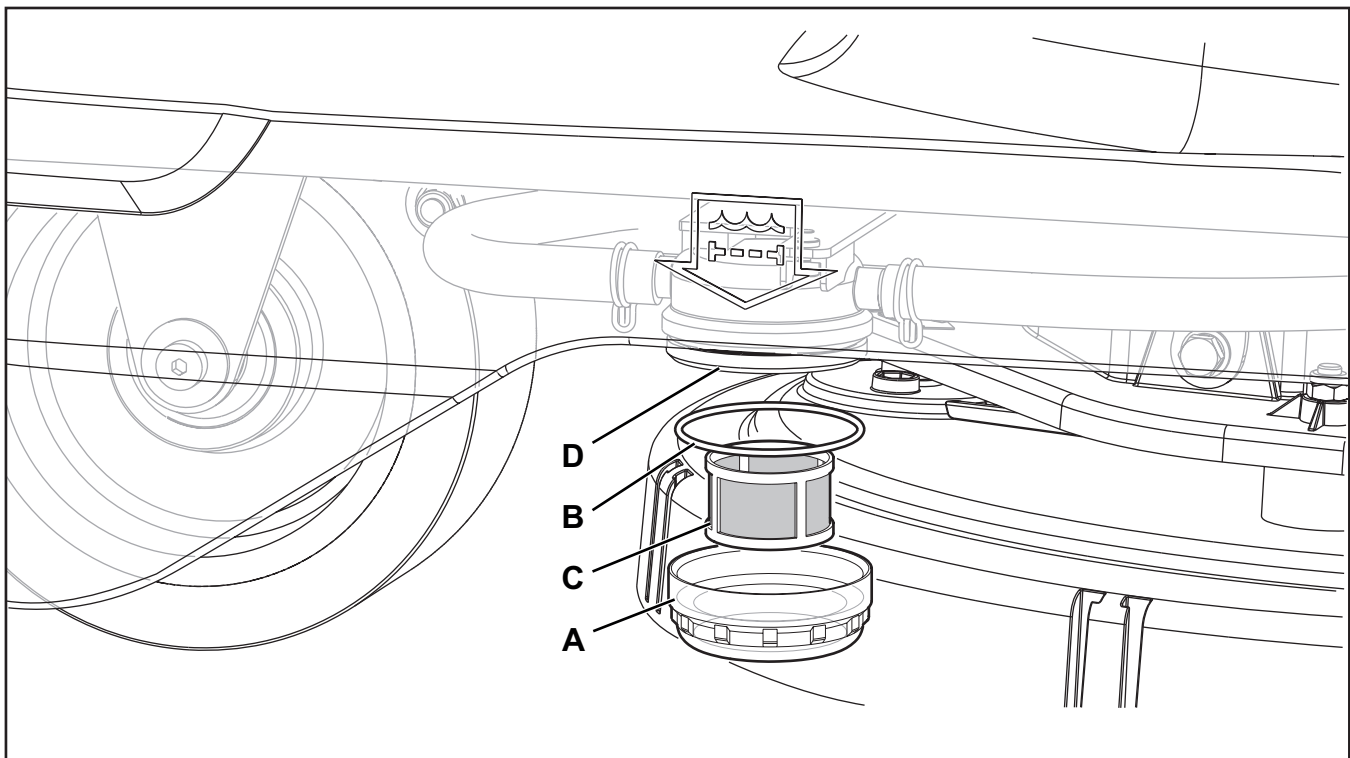


Figure 7

## Cleaning the Chemical Mixing System Detergent Tank

1. Drive the machine to the appointed disposal area.
2. Ensure that the machine is off and the operator key (41) has been removed.
3. Lift the recovery tank cover and check that it is empty; if not, empty it using the drain hose.
4. Close the recovery tank cover.
5. Lift the recovery tank assembly and the driver's seat.
6. Unscrew the plug (A, Figure 8) from the detergent tank (B).
7. Remove the tank.
8. Rinse and wash out the tank with clean water in the appointed disposal area.
9. Replace the detergent tank (B) as shown in the figure, then refit the plug (A).
10. When the detergent tank has been drained, it may be necessary to drain the Chemical Mixing System too (see procedure in Draining the Chemical Mixing System paragraph).

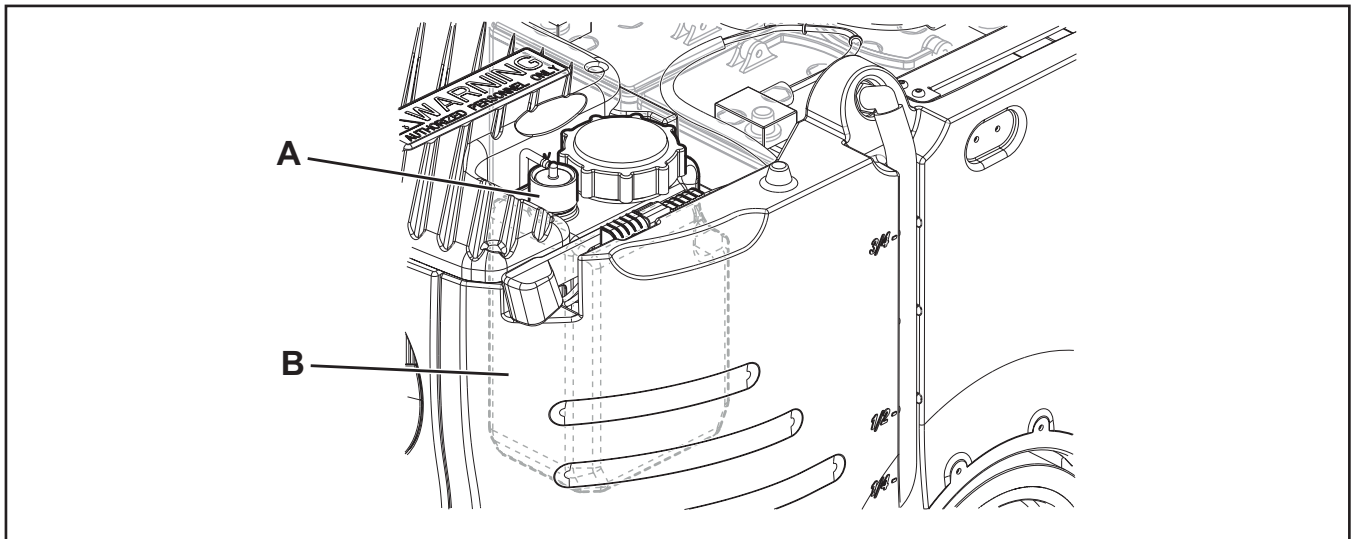




Figure 8



## Draining the Chemical Mixing System

Clean the detergent tank as shown in the previous section.



To remove residual detergent from the detergent hoses and pump, proceed as follows.

1. Turn the ignition key to “I”.

2. Press the One-Touch button . Check that the detergent quantity indicator  on the display has at least one segment lit.

3. Press the solution flow adjustment button  and the detergent percentage adjustment button  together, until the screen appears on the display (after approximately 5 seconds).



4. Release buttons  and  and wait for the countdown timer on the display to finish and the vacuum system to be activated.
5. Collect the detergent remained on the floor.
6. Remove the operator key.
7. Lift the recovery tank assembly and the driver's seat, then check that the detergent tank hose is empty, otherwise perform steps 2 to 6 again.



Note:

*The draining cycle lasts about 30 seconds, then the vacuum function automatically turns on, which allows to remove the detergent remained. The draining cycle can also be performed with the detergent tank full of water, thus cleaning the system thoroughly. It is advisable to perform this type of draining to clean the Chemical Mixing System from dirt and deposits if the machine has not been used/cleaned for a long time. The draining cycle can also be performed to quickly fill the detergent supply hose when the tank is full but the system is still empty. If necessary, the draining cycle can be performed several times in succession.*

## Troubleshooting

| Trouble   | Possible Causes   | Remedy  |
|---|---|---|
| Small amount of solution or no solution reaches the brush   | The solution filter is clogged/dirty  | Clean the filter  |
|   | Solution supply valve locked in (semi) closed position                      | Replace the valve   |
|   | Solenoid valve (EV1) broken or electrical connection interrupted            | Replace the solenoid valve/repair the electrical connection |
|   | Presence of debris in solution tank blocking the outlet hole                | Clean the tank  |
|   | Presence of debris in the solution hose, blocking the passage of the liquid | Clean the hoses   |
|   | Function electronic board (EB1) faulty                                      | Replace   |
|   | Display electronic board (EB2) faulty                                       | Replace   |
|   | Dashboard instrument electronic board (EB4) faulty                          | Replace   |
| The solution reaches the brush also when the machine is off | Presence of dirt or scale in solenoid valve (EV1)                           | Clean the solenoid valve                                    |
|   | Solenoid valve (EV1) broken   | Replace the solenoid valve                                  |

## Troubleshooting (Continues)

| Trouble   | Possible Causes  | Remedy   |
|---|--|--|
| The Chemical Mixing System detergent is not reaching the brush, or is not arriving in sufficient quantity | The detergent flow percentage is too low   | Check/change the percentage as shown in the User Manual                                    |
|   | The hydraulic circuit upstream of the detergent pump is not triggered                              | Check if the hose is filled and, if necessary, perform one or more draining cycles         |
|   | The pump (M1) is broken or there is an open in the electrical connection                           | Replace the pump/repair the electrical connection  |
|   | There is foreign material/debris in the detergent tank clogging the output hole                    | Clean the tank   |
|   | There is debris in the detergent hoses clogging the detergent flow                                 | Clean the hoses  |
|   | Function electronic board (EB1) faulty   | Replace  |
|   | Display electronic board (EB2) faulty  | Replace  |
|   | Dashboard instrument electronic board (EB4) faulty   | Replace  |
| The Chemical Mixing System detergent is reaching the brush even with the machine off                      | The pump (M1) is broken  | Replace  |
|   | The one-way valve is broken  | Replace  |
| Water is entering the Chemical Mixing System tank   | The one-way valve is broken  | Replace  |
| The Chemical Mixing System will not activate  | Dashboard instrument electronic board (EB4) faulty   | Replace  |
|   | The function electronic board (EB1) has not been set for operation with the Chemical Mixing System | If present, remove the jumper (J6) (Figure 9) on the rear of the function electronic board |

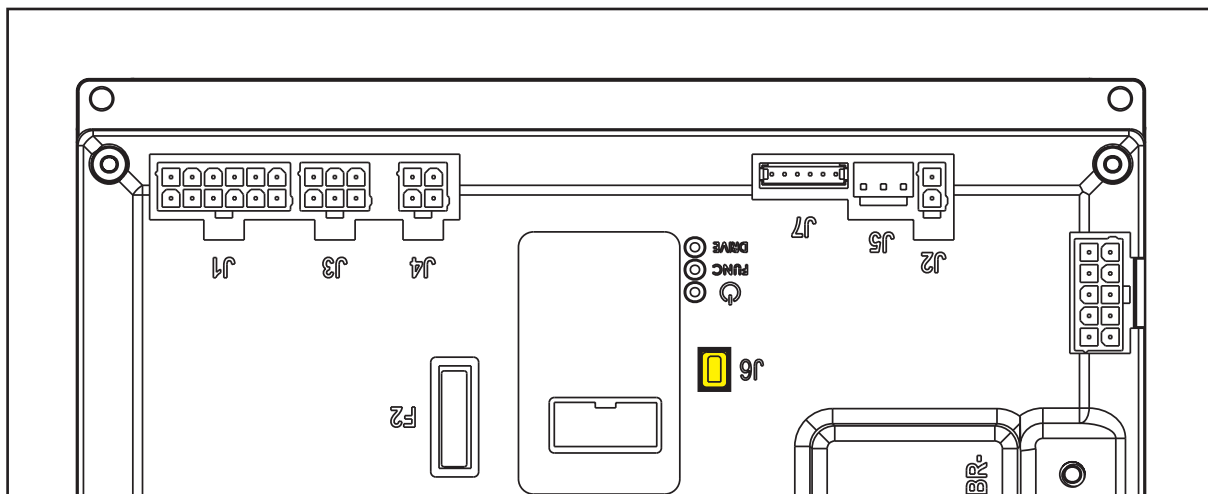


Figure 9

### Checking the Water Level Sensor Operation

1. Turn the ignition key to “I” holding down both the horn button (A, Figure 10) together with the adjustment percentage detergent button (B).
2. Press hold 1 second the reverse button (C) to switch to the screen menu (D).

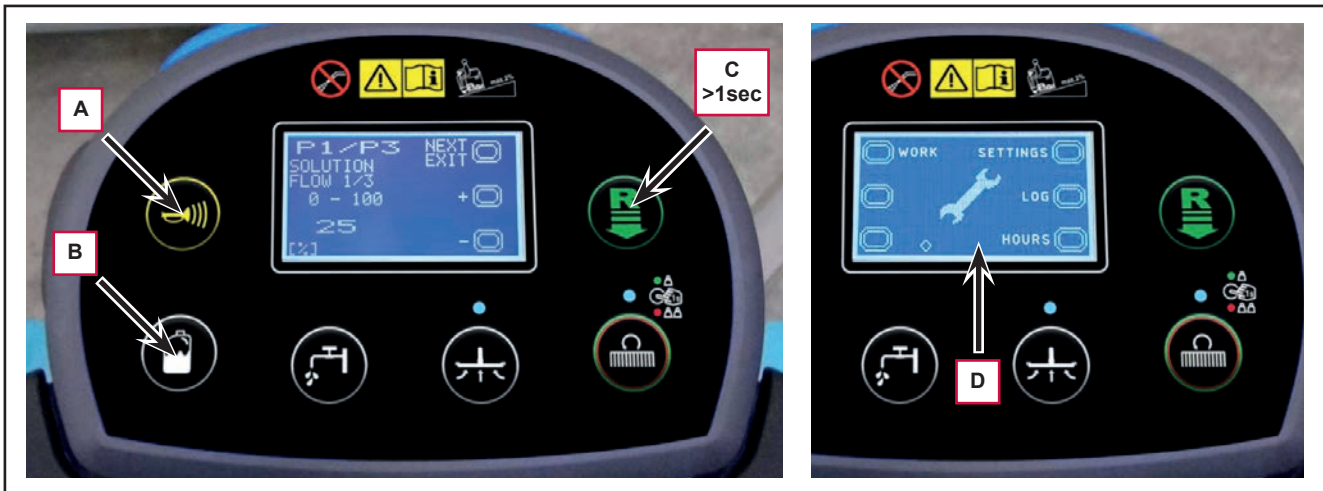


Figura 10

3. With the solution tank more than half full, the symbol displayed is (A, Figure 11).
4. With the solution tank less than half full, the symbol displayed is (B).

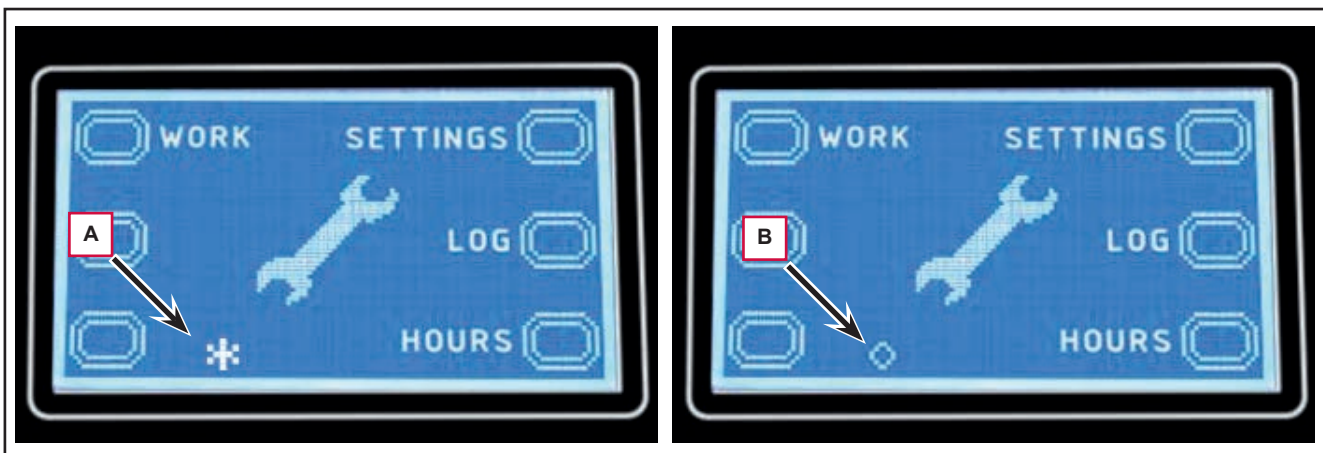



Figure 11

## Removal and Installation

### Solenoid Valve Disassembly/Assembly

#### Disassembly

1. Drive the machine on a level floor or on a hoisting system to facilitate the disassembly procedures.
2. Remove the brush.
3. Remove the two screws (A, Figure 12) under the brush deck.
4. Turn the ignition key to “I”.
5. Lower the brush deck by pressing the One-Touch button .
6. Switch off the machine and disconnect the

battery connector.

7. Unscrew and disconnect the connection (B).
8. Remove the elastic clamp (C) and disconnect the detergent supply hose (D) from the solenoid valve.
9. Disassemble the solenoid valve (E).

#### Assembly

10. Assemble the components in the reverse order of disassembly.

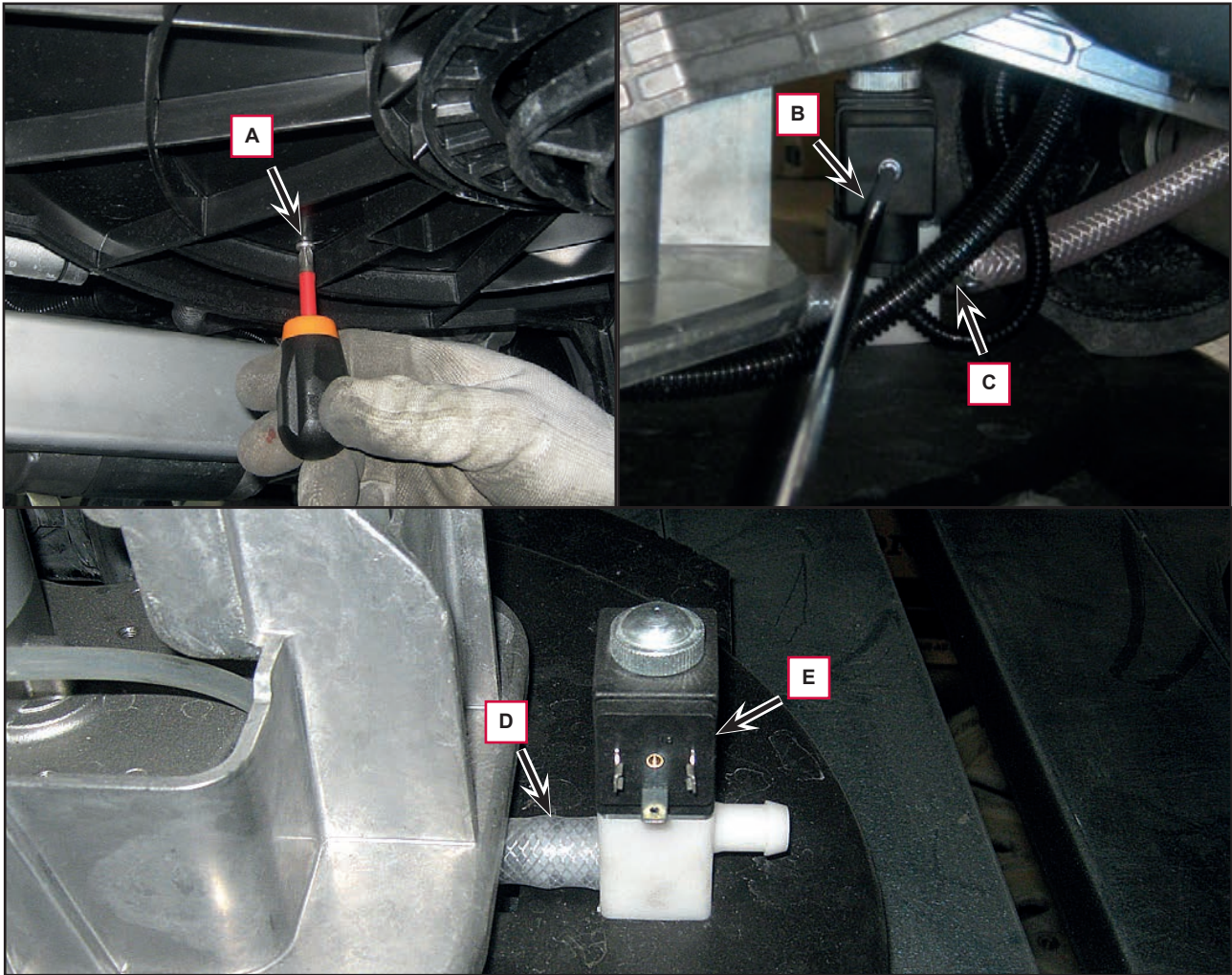


Figure 12

## Detergent Pump Disassembly/Assembly

### Disassembly

1. Drive the machine on a level floor.
2. Switch off the machine and disconnect the battery connector.
3. Lift the recovery tank assembly and the driver's seat, then disassemble the electronic component compartment cover.
4. Disconnect the connectors (A) (Figure 13), the tank hose (B) and brush hose (C).
5. Unscrew the two screws (D) and remove the detergent pump (E).

### Assembly

6. Assemble the components in the reverse order of disassembly, ensuring the supply hoses (B) and (C) are correctly fitted on the detergent pump.

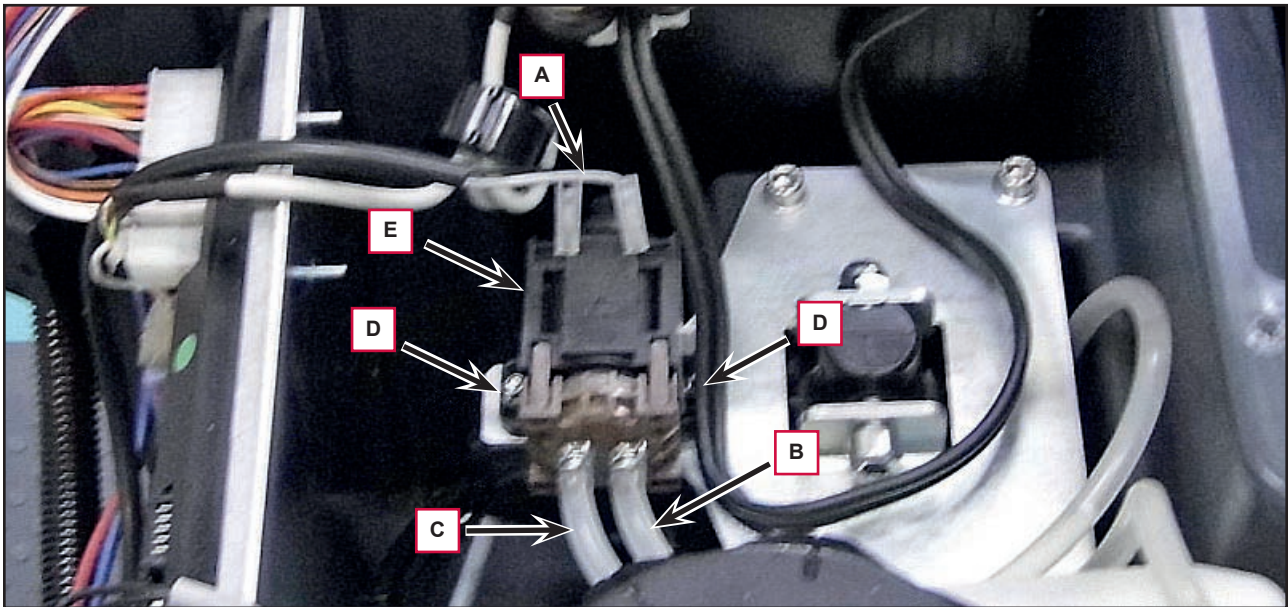


Figure 13



### Water Level Sensor Disassembly/Assembly

1. Drive the machine on a level floor.
2. Switch off the machine and disconnect the battery connector.
3. Lift the recovery tank assembly and the driver's seat, then disassemble the electronic component compartment cover.
4. Unscrew the screw (A, Figure 13) and remove the sensor holder (B).
5. Unscrew the two screws (C) and remove the water level sensor (D).

#### Assembly

6. Assemble the components in the reverse order of disassembly.

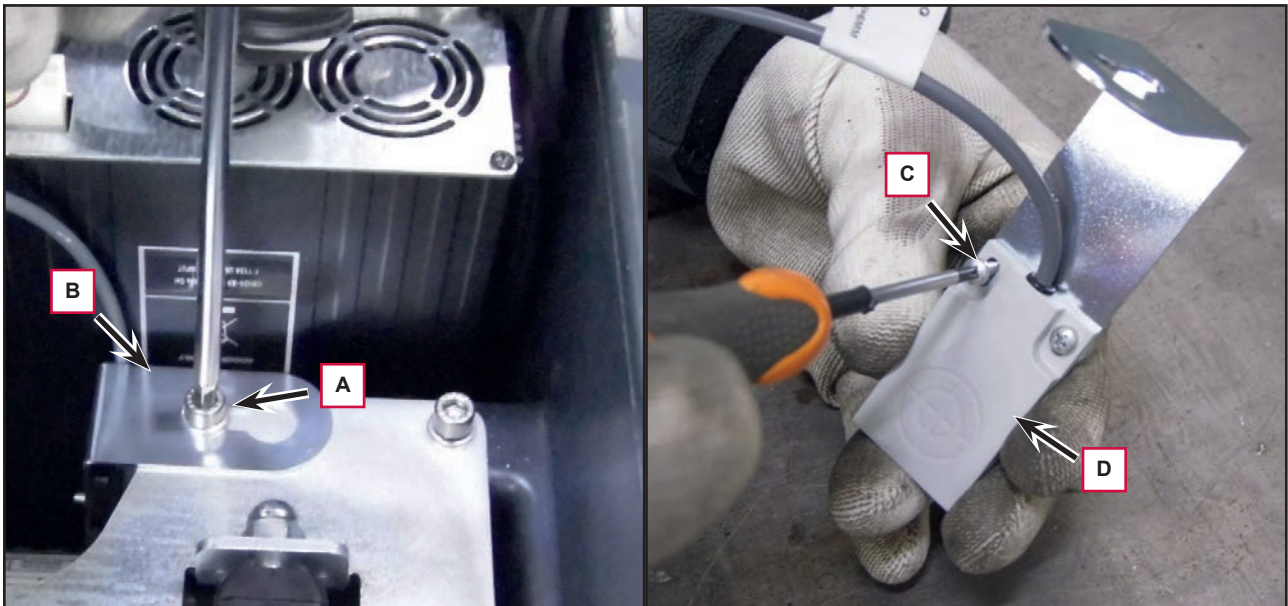


Figure 13

## Specifications

| Description / Model                                     | Nilfisk<br>Scubtec R253                                   | Nilfisk<br>Scubtec R253 full PKG<br>Clarke RA40 |
|---|---|---|
| Solution tank capacity                                  | 18.5 US gal (70 liters)                                   |   |
| Solution flow values                                    | 0.75 cl/m / 1.5 cl/m / 3.0 cl/m / (2.8 L/min, if enabled) |   |
| Chemical Mixing System kit tank capacity                | 1.3 US gal (5 L)  |   |
| Chemical Mixing System kit detergent percentage setting | Ratio 1:500 ÷ 1:33 (0.25 % ÷ 3 %)                         |   |

# Squeegee System

## Functional Description

The squeegee system cleans the liquid off the floor, which is then collected by the recovery system.

The squeegee is mounted on castors and the weight of the system presses it down on the floor.

The squeegee is held in place by two quick-fit wing nuts in the squeegee support slots. In case of fixed obstacles, the quick-fit system allows for squeegee immediate removal.

The squeegee support is held on the frame by two tie rods and a centring spring, allowing some lateral movement.

The angle of the squeegee and the correct adherence of the blades on the floor can be adjusted with a knob.

The front blade has an opening in the bottom edge so the squeegee can collect the water on the floor. The design and the central duct make it easy for the squeegee to clear the water. The rear blade edge is smooth.

All 4 functional edges of each blade can be used before it needs replacing.

The squeegee is lifted and lowered by an actuator (M6) located in the solution tank compartment. It is activated at the same time as the brush deck.

The squeegee actuator (M6) has 2 limit microswitches (not accessible). Every time it is raised or lowered, the actuator is activated by the electronic board for 15 seconds. The squeegee must reach the correct limit switch by the end of this time.

In any case the electronic board cuts off the power supplied to the actuator after 15 seconds, to prevent damaging the actuator.

## Wiring Diagram

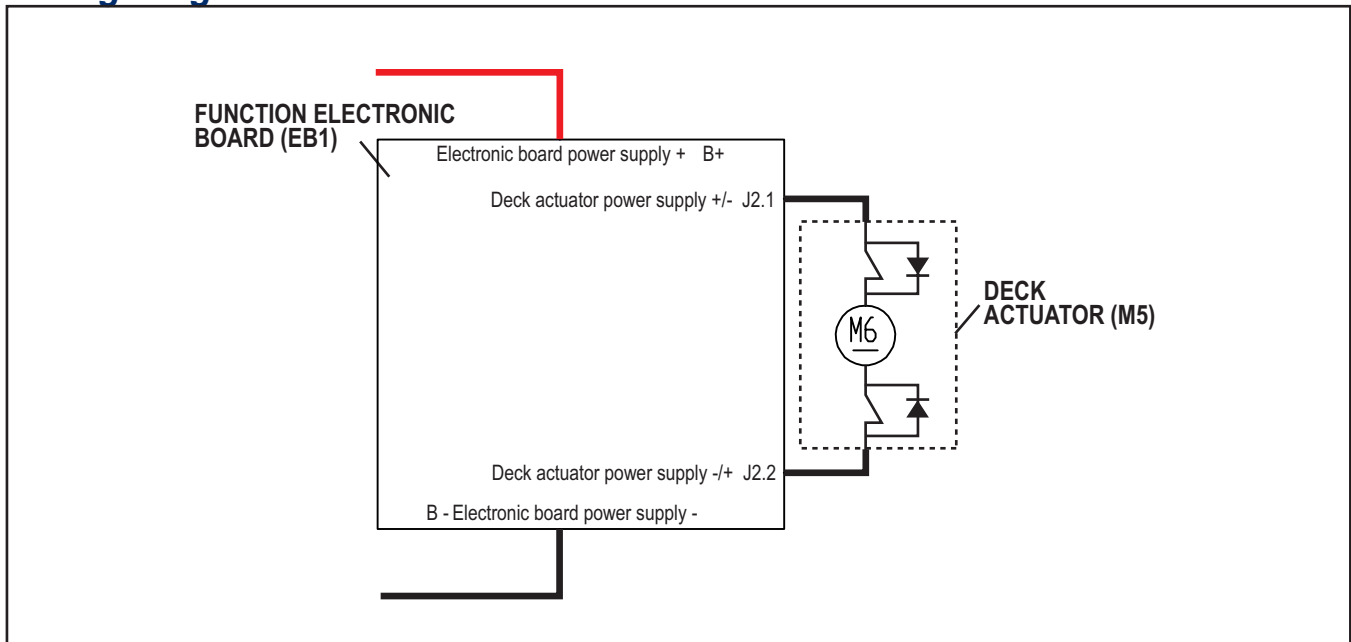


Figure 1

## Component Locations

- Bumper wheels
- Squeegee blades
- Squeegee reset spring
- Squeegee adjusting knob
- Squeegee support
- Mounting handwheels
- Actuator (M6)
- Tie rods

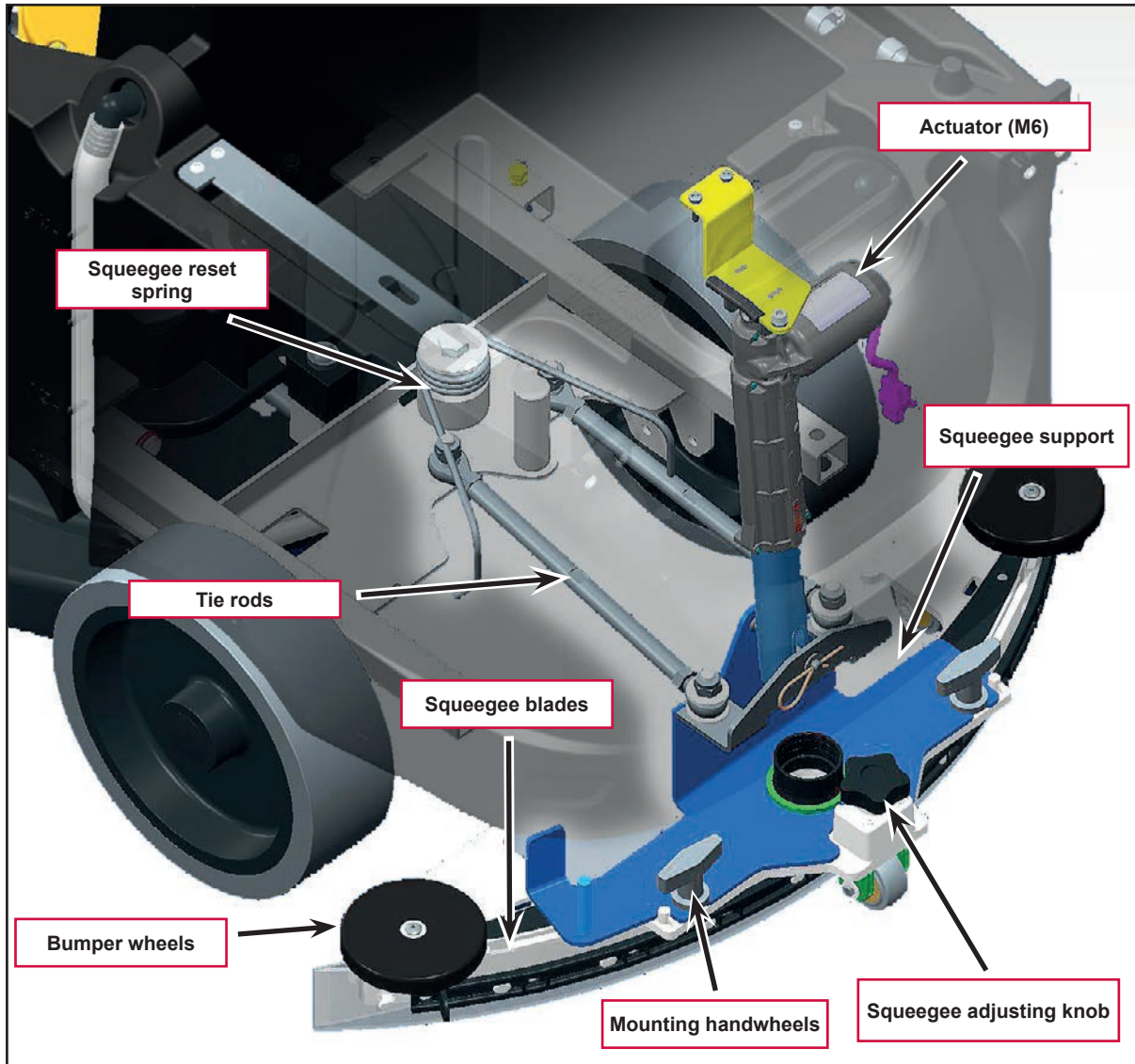


Figure 2

## Maintenance and Adjustments

### Squeegee cleaning



**Note:** *The squeegee must be clean and its blades must be in good conditions in order to get a good drying.*



**Warning!** *It is advisable to wear protective gloves when cleaning the squeegee because there may be sharp debris.*

1. Drive the machine on a level floor.
2. Ensure that the machine is off and the operator key has been removed.

3. Loosen the handwheels and remove the squeegee.
4. Wash and clean the squeegee. In particular, clean the compartments (A, Figure 2) and the hole (B). Check that the front blade (C) and the rear blade (D) are integral and free from cuts and lacerations; if necessary replace them.
5. Assemble in the reverse order of disassembly.

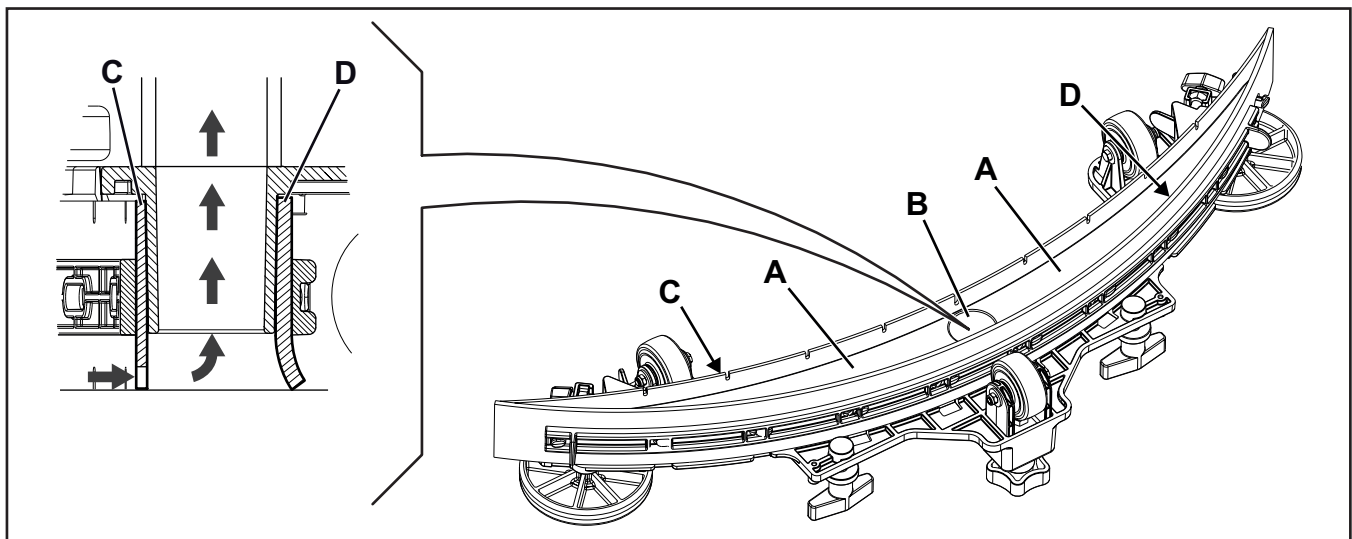


Figure 2

## Checking/Replacing the Squeegee Blades



**Note:** The squeegee must be clean and its blades must be in good conditions in order to get a good drying.



**Warning!** It is advisable to wear protective gloves when cleaning the squeegee because there may be sharp debris.

1. Clean the squeegee as shown in the previous paragraph.
2. Check the condition of the front (C, Figure 3) and rear (D) blades, ensuring there are no cuts and tears; if necessary, replace them as shown below. Check that the front corner (E) of the rear blade is not worn; otherwise, turn the blade to replace the worn corner with one of the three remaining intact corners. If the other corners are worn too, replace the blade according to the following procedure:
  - Using the tab (F), release and remove the elastic strap (G) from the fasteners (H), then turn or replace the rear blade (D).
  - Install the blade in the reverse order of removal.
  - Unscrew the handwheels (I) and remove the strap (J), then turn or replace the front blade (C).
  - Install the blade in the reverse order of removal.
3. Install the squeegee on the support and screw down the handwheels.
4. Lower the squeegee to the floor to check the height of the blades, proceeding as follows:
  - Check that the lip (K) of the front blade (C) and the lip (L) of the rear blade (D) are resting as shown in the figure.
  - Use the knob to make adjustments.

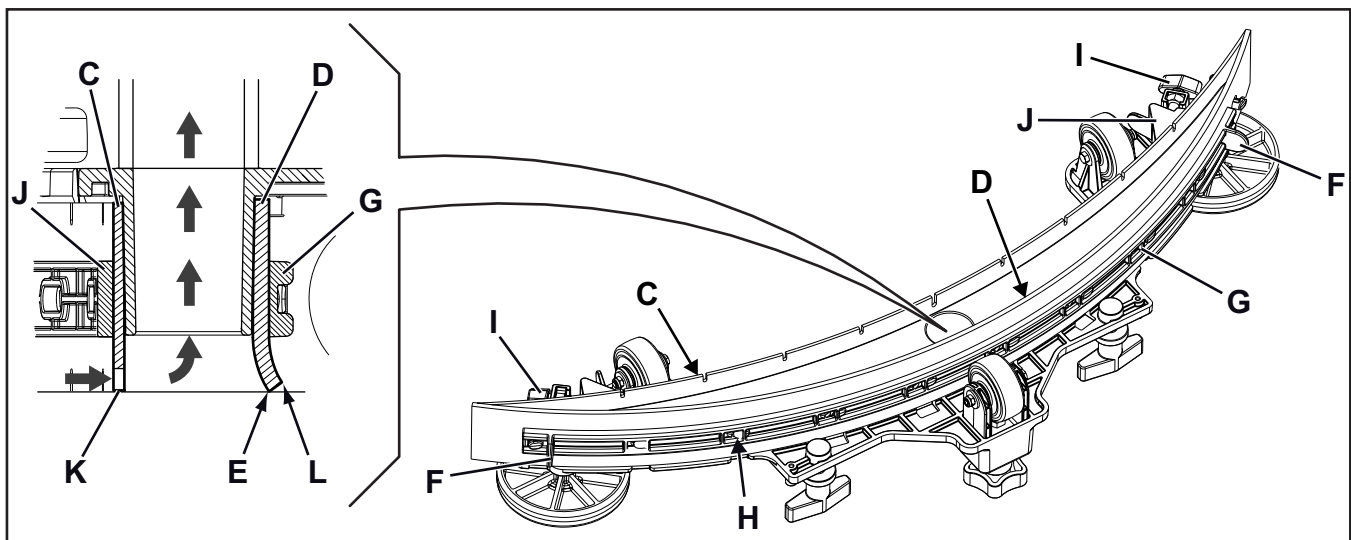


Figure 3

## Troubleshooting

| Trouble   | Possible Causes                                | Remedy  |
|---|--|---|
| Suction of dirty water is insufficient or non-existent            | Squeegee or vacuum hose clogged or damaged     | Clean or repair/replace   |
| The squeegee leaves lining on the floor or does not collect water | There is debris under the blade                | Remove  |
|   | Squeegee blade lips damaged or worn            | Replace   |
|   | Squeegee not balanced                          | Adjust with the relevant handwheel  |
| The squeegee cannot be lifted/lowered                             |  | See the chapter Control System, Function Electronic Board (EB1) Error Codes                                     |
|   | Squeegee lifting/lowering actuator (M6) broken | Replace   |
|   | Break in actuator wiring                       | Check the connections according to the instructions in the Electrical System chapter, Troubleshooting paragraph |
|   | Function electronic board (EB1) damaged        | Replace   |

## Removal and Installation

### Squeegee Lifting Actuator Disassembly/Assembly

#### Disassembly

1. Drive the machine on a level floor.
2. Lower the squeegee.
3. Ensure that the machine is off and the operator key has been removed.
4. Disassemble the retaining spring (A, Figure 4), retrieve screws and washers.
5. Disconnect the squeegee power supply connection (B).
6. Remove the two screws (C) and the screw (D), then lift the actuator plate (E).
7. Remove the nut (F) and retrieve the screw (G).
8. Replace the actuator (H).

#### Assembly

9. Assemble the components in the reverse order of disassembly.

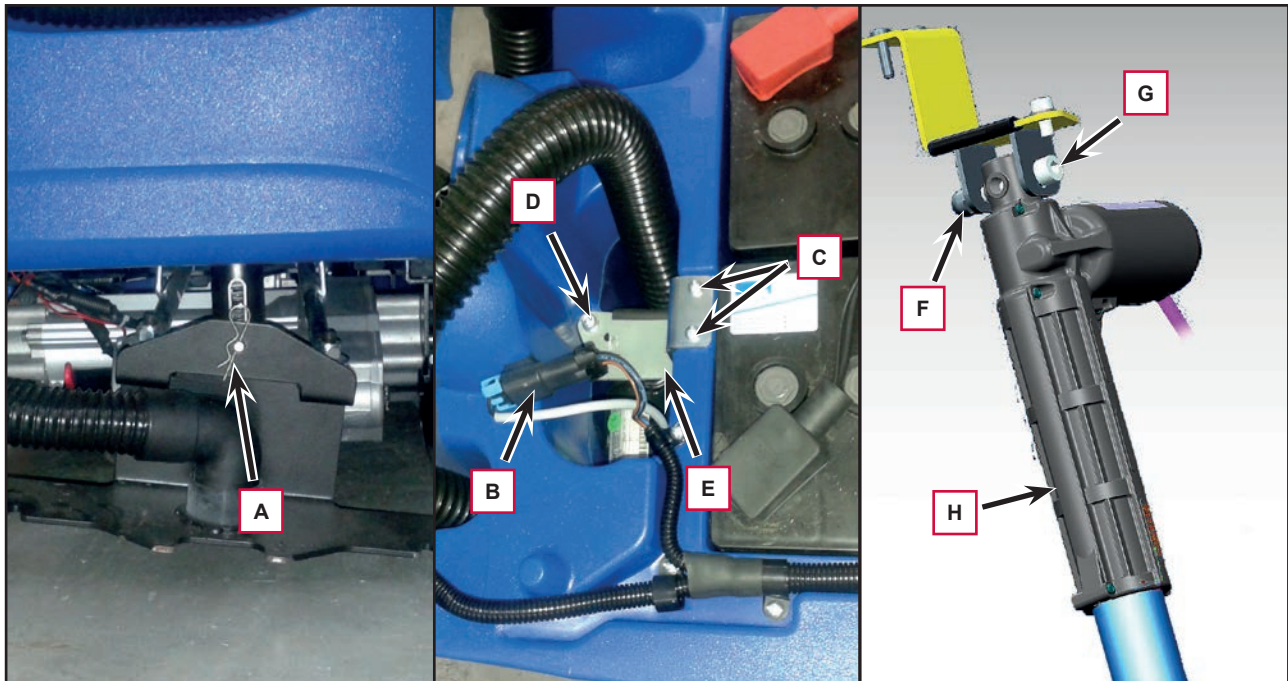


Figure 4



## Squeegee Tie Rod Disassembly/Assembly

### Disassembly

1. Drive the machine on a level floor or on a hoisting system to facilitate the disassembly procedures.
2. Lower the squeegee.
3. Ensure that the machine is off and the operator key has been removed.
4. Unscrew the nuts (A, Figure 5), retrieve the washers and spacers.
5. Carefully disassemble the tie rod (B) from the studs, by paying attention to the squeegee reset spring (C).

### Assembly

6. Assemble the components in the reverse order of disassembly, and note the following:
  - Assemble the tie rod (B) by loading it with the squeegee reset spring (C).

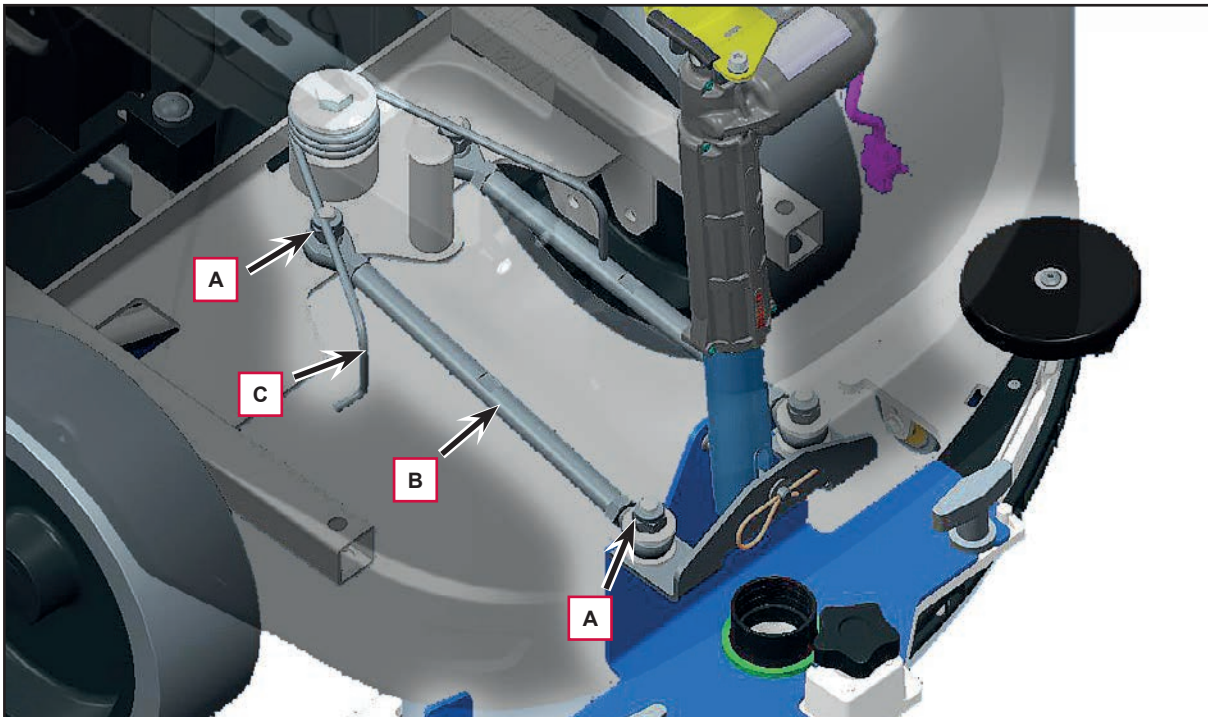


Figure 5

## Specifications

| Description / Model     |                            | Nilfisk<br>Scubtec R253 | Nilfisk<br>Scubtec R253 full PKG<br>Clarke RA40 |
|-------------------------|----------------------------|-------------------------|---|
| Squeegee width          |                            | 28.3 in (720 mm)        |   |
| Actuator technical data | Spring load                | 70 ÷ 100 N              |   |
|                         | Total travel               | 3 in (77 mm)            |   |
|                         | Maximum speed              | 16 mm/s                 |   |
|                         | Voltage                    | 24V                     |   |
|                         | No load current Amps max   | 0,5 A                   |   |
|                         | Full load current Amps max | 3 A                     |   |
|                         | Stall Amps                 | 5,5 A                   |   |
|                         | Protection class           | IP 44                   |   |
|                         | Insulation class           | A                       |   |

## Steering System

### Functional Description

The steering system connects the steering wheel to the front wheel.

The reduction gear pinion transmits the movement to the steering crown connected to the front wheel. The front wheel assembly is equipped with anti-skid control sensor (SW4).

The sensor is mechanically activated through a pin when it reaches a definite steering angle considered critical.

The sensor interfaces with the anti-skid steering system managed using the accelerometer built into the functions board (EB1) (see the wheel traction system chapter).

When necessary, the anti-skid control sensor reduces the speed to a safe speed when turning in order to avoid sudden skidding, thus increasing machine stability in all conditions.

The system activation is shown by the icon  on the display.

### Component Locations

- Front fairing
- Steering column
- Steering pinion
- Steering crown
- Steering crown
- Anti-skid control sensor (SW4)
- Front wheel

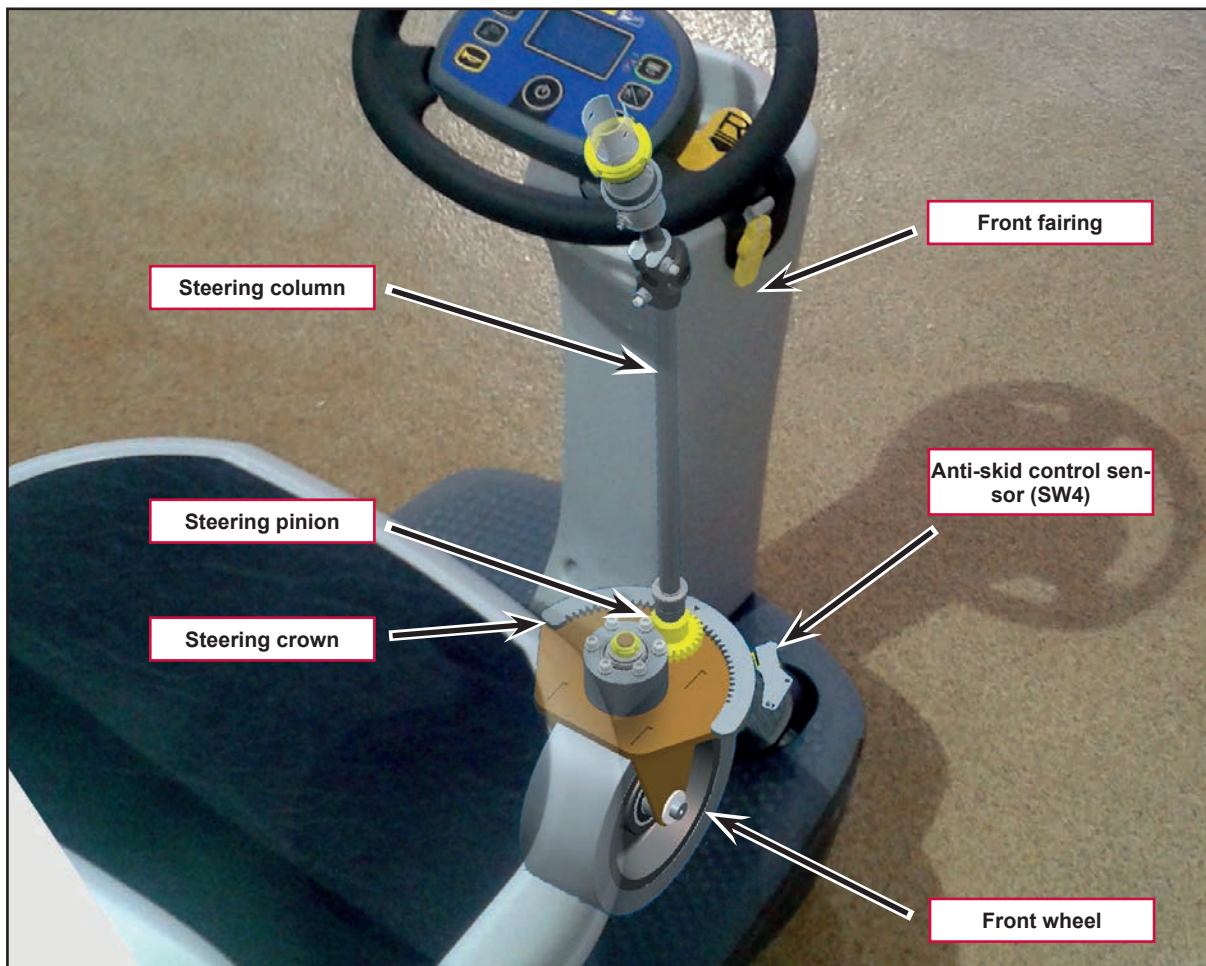


Figure 1

## Specifications

| Description / Model                            | Nilfisk<br>Scubtec R253          | Nilfisk<br>Scubtec R253 full PKG<br>Clarke RA40 |
|--|----------------------------------|---|
| Turning space for U-turns                      | 71 in (1800 mm)                  |   |
| Front steering wheel diameter                  | 7.9 in (200 mm)                  |   |
| Front wheel specific pressure on the floor (*) | 189 psi (1.3 N/mm <sup>2</sup> ) |   |
| Front wheel maximum turning angle              | 70°                              |   |
| Steering turning angle                         | 230°                             |   |
| Steering reduction rate                        | 3:1                              |   |

(\*) Machines have been tested under the following conditions:

- Battery maximum size
- Maximum brush and squeegee size
- Full detergent tank
- Optional equipment installed
- Wheel weight checked
- Print on the floor checked on cement for each single wheel
- Result expressed as maximum value for rear wheels

## Wheels, Drive System

### Functional Description

Machine movement is provided by the gearmotor unit (M3).

The gearmotor unit (M3) consists of an electrical motor, a reduction unit with differential, an electromagnetic brake (BRK) (built in the electrical motor) and driving wheels. It is fastened to the machine frame.

The electromagnetic brake keeps the machine braked when the machine is off or whenever it is stopped.

The electromagnetic brake is equipped with an unlocking lever, to easily move the machine manually. After moving the machine manually, engage the electromagnetic brake again.



**Warning!** *Do not use the machine when the electromagnetic brake is disengaged. If the lever is not repositioned after pushing/towing the machine, the electromagnetic brake is disengaged. For safety reasons, it is recommended to disengage the electromagnetic brake only for the time necessary to manually move the machine.*

The operator regulates the transfer speed, the working speed and reverse gear by means of the drive pedal, which is directly connected to the drive pedal potentiometer (RV1). The reverse gear is selected by pressing the right lever on the steering wheel:


The function electronic board (EB1) checks that the drive pedal is not pressed when the machine is started; otherwise, an alarm is generated (see “Function Electronic Board Alarm Codes” paragraph, in “Control System” chapter) and the drive system is inhibited.

When the drive pedal returns to the rest position, the alarm is automatically deactivated (without having to turn the machine off and on again).

When the drive pedal is pressed, the function electronic board (EB1) powers the electromagnetic brake to release the wheel, then activates the gearmotor (M3) with a proportional voltage on the basis of the pedal position. The acceleration ramps and maximum speed can be set via the corresponding parameters (see “Displaying and Modifying User Modifiable Parameters” paragraph, in “Control System” chapter).

An anti-skid system, built in the function electronic board, reduces the speed to a safe speed when turning and when the machine tilts laterally in order to avoid sudden skidding, thus increasing machine stability in all conditions.



The system activation is shown by the icon  on the display.

The automatic anti-skid system constantly detects lateral acceleration using an accelerometer installed in function electronic board (EB1). If the lateral accelerometer detects a speed higher than the preset value (set using the AMAX parameter, see “Displaying and Modifying User Modifiable Parameters” paragraph, in “Control System” chapter) the system reduces the speed so the lateral acceleration remains below this limit.

The driver’s seat microswitch is located inside the driver’s seat and the machine drive system is only enabled if the operator is seated in the driver’s seat.

## Wiring Diagram

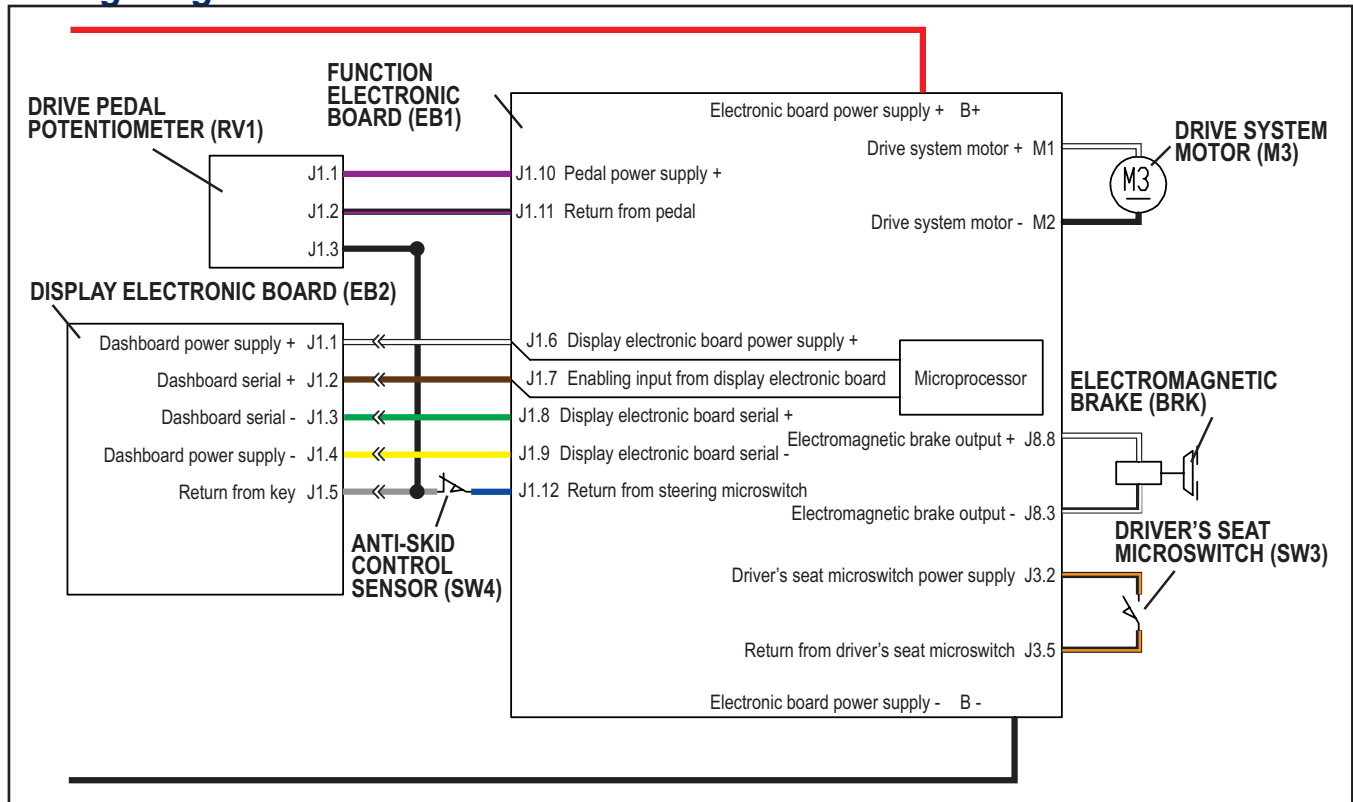


Figure 1

### Component Locations

- Driver's seat microswitch (SW3)
- Driver's seat microswitch connector
- Drive pedal with potentiometer (RV1)

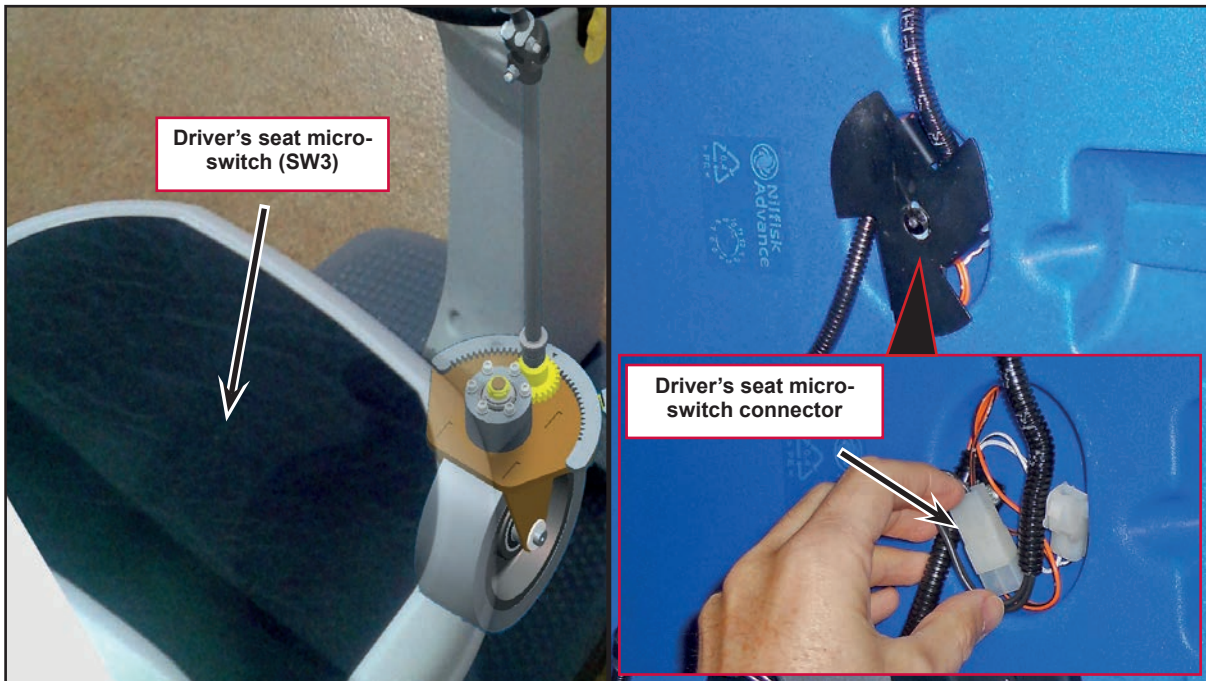


Figure 2



Figure 3

## Component Locations (continues)

- Driving wheels
- Gearmotor unit (M3)
- Electromagnetic brake (BRK)

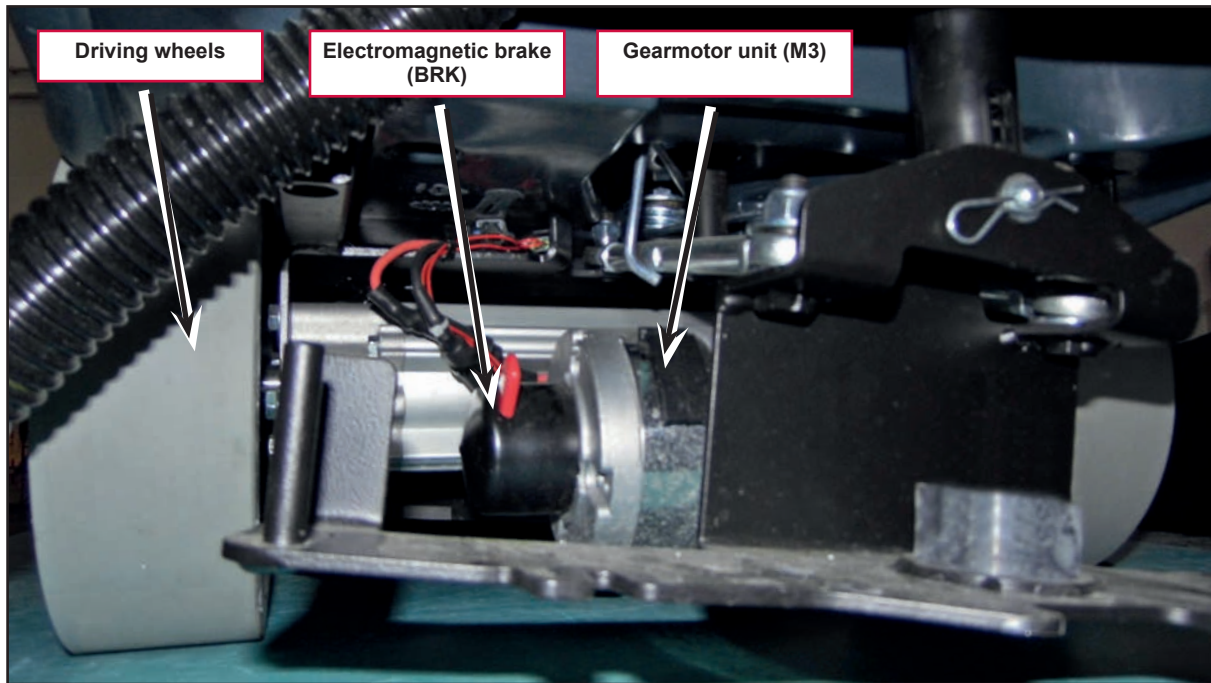


Figure 4



## Troubleshooting

| Trouble   | Possible Causes  | Remedy   |
|---|--|--|
| The machine does not move   | Battery voltage too low  | Charge the battery   |
|   | Speed potentiometer (RV1) incorrectly regulated or broken                      | Replace  |
|   | Function electronic board (EB1) faulty   | Replace  |
|   | Wiring damaged   | Check all connections inside the electrical component compartment, included those of the function electronic board |
|   | Drive system motor (M3) carbon brushes worn                                    | Replace  |
|   | Drive system motor (M3) faulty   | Replace  |
|   | The electromagnetic brake (BRK) is faulty                                      | Replace  |
| The electromagnetic brake (BRK) is not engaged when the machine stops | The electromagnetic brake locking/unlocking lever is turned to unlock position | Turn the lever to lock position  |

## Drive System Gearmotor Amperage Test



**Warning!** This procedure must be performed by qualified personnel only and with the help of an assistant.

1. Drive the machine on a level floor.
2. Lift the recovery tank assembly and the driver's seat.
3. Apply a jumper wire (A, Figure 6) on the driver's seat sensor connector to disable the system.
4. Disassemble the electronic component compartment cover and the function electronic board panel.
5. Place a suitable lifting device (B) to raise one side of the machine approximately 2 cm from the floor (C) and allow one driving wheel to turn freely.



**Warning!** Pay attention to the rotation of the driving wheel when performing the following steps.

6. Apply the amp clamp (D) on one (black) cable (E) of the drive system motor wiring harness.
7. Turn on the machine and drive it at the maximum forward speed by pressing the drive pedal and check that the amperage is 3 - 7A at 24V.
8. Release the drive pedal.
9. Switch off the machine and remove the amp clamp (D).
10. If the amperage is higher, perform the following procedures to detect and correct the abnormal amperage:
  - Check if there is dust or debris preventing the wheel rotation.
  - If necessary, check the motor carbon brushes;
  - If necessary, disassemble the motor and check the condition of all its components.
11. If the above-mentioned procedures do not produce the correct readings for the gearmotor amperage, the gearmotor must be replaced.

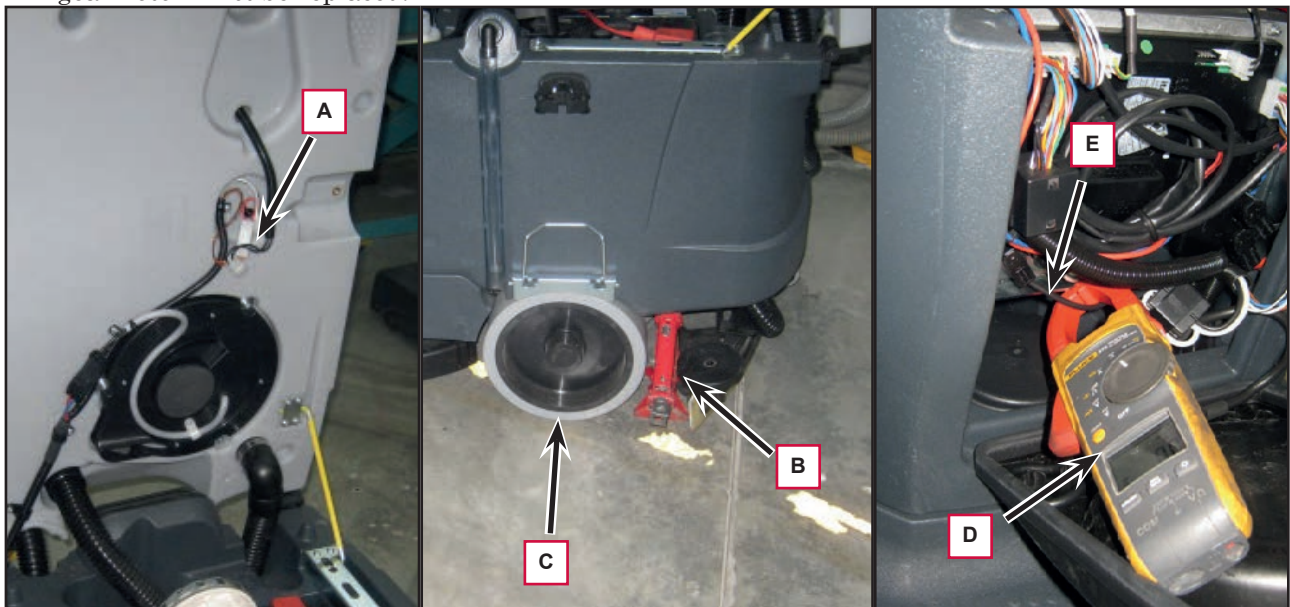


Figure 6

## Removal and Installation

### Drive Pedal Potentiometer Disassembly/Assembly

#### Disassembly

1. Drive the machine on a level floor or on a hoisting system to facilitate the disassembly procedures.
2. Remove the operator key and disconnect the red battery connector
3. Lift the machine as shown (A, Figure 5).
4. Remove the 2 screws (B) and disassemble the accelerator pedal (C).
5. Under the machine disconnect the connection (D) of the drive pedal potentiometer (E).
6. Remove the 3 screws (F), then disassemble the drive pedal potentiometer (E).

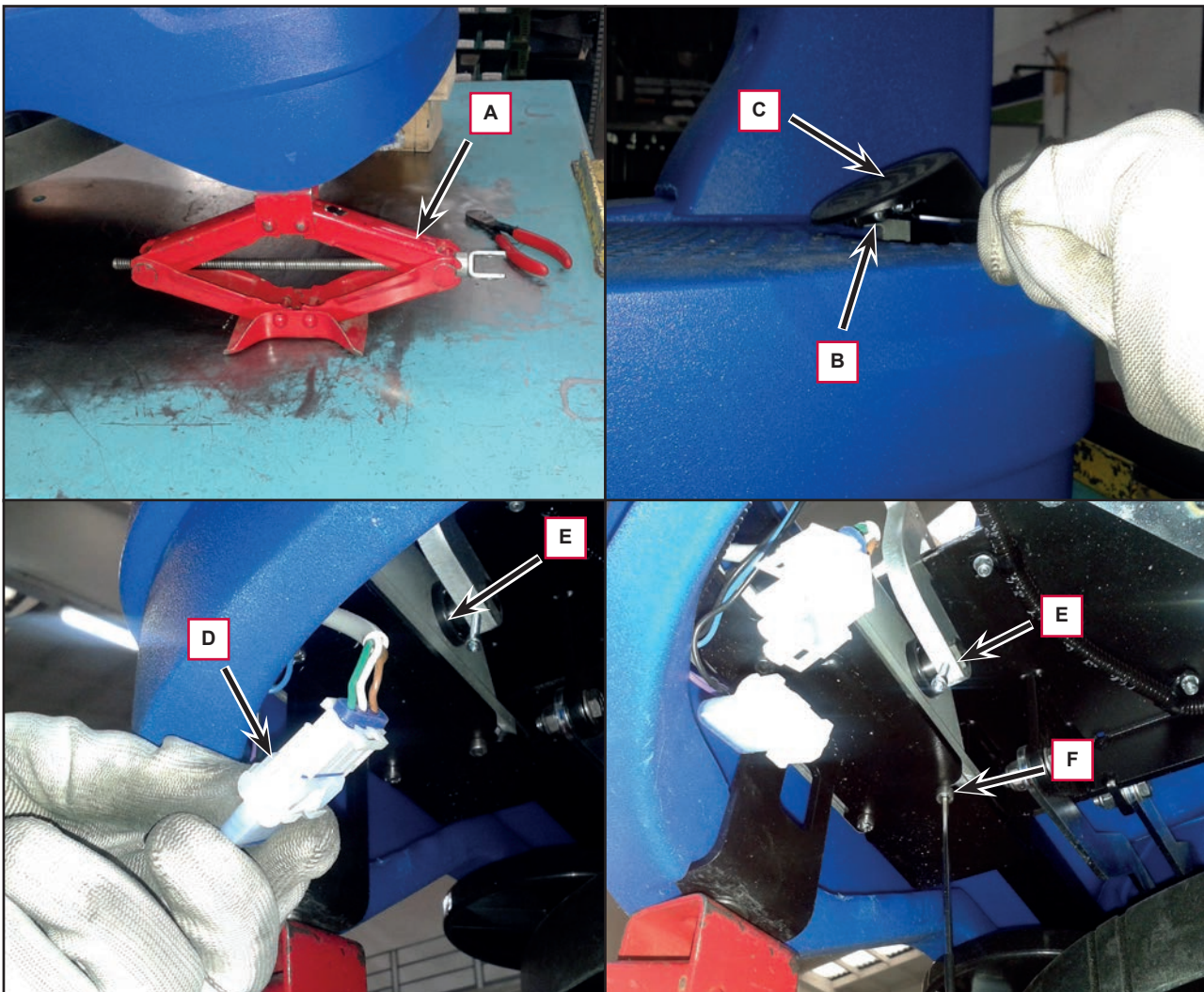


Figure 5

#### Assembly

7. Assemble the components in the reverse order of disassembly.

## Drive System Gearmotor Disassembly/Assembly



**Warning!** This procedure must be performed by qualified personnel only and with the help of an assistant.

1. Drive the machine on a level floor or on a hoisting system to facilitate the disassembly procedures.
2. Place a suitable lifting device (A, Figure 7) to raise one side of the machine approximately 2 cm from the floor.
3. Remove the plug (B), remove the screw (C) and retrieve the washer.
4. Remove the wheel (D) and retrieve the key.
5. Disconnect the connection (E).
6. Remove the 4 screws (F) and retrieve the washer.
7. Repeat step 2 to 6 for the other wheel, then carefully disassemble the gearmotor (G) from the machine.



Figure 7

## Gearmotor Carbon Brushes Check/Replacement

### Check

1. Remove the gearmotor unit from the machine.
2. At the workbench, remove any dust and dirt from around the drive system motor carbon brushes.
3. Remove the clamp (A, Figure 8) by disengaging the tab (B).
4. Remove the screw (C) of the carbon brushes lead-in wires.
5. Carefully disengage the retaining spring (D) and remove the carbon brushes (E).
6. Check the carbon brushes (E) for wear. The carbon brushes are worn out when:
  - They do not make sufficient contact with the armature of the motor due to their wear
  - When their contact surface is not intact
  - When the residual stroke is below 0.12 in (3 mm)
  - When the thrust spring etc. is broken
7. Replace the carbon brushes as an assembly.

### Reassembly

8. Assemble the components in the reverse order of disassembly.
9. Reassemble the gearmotor unit.

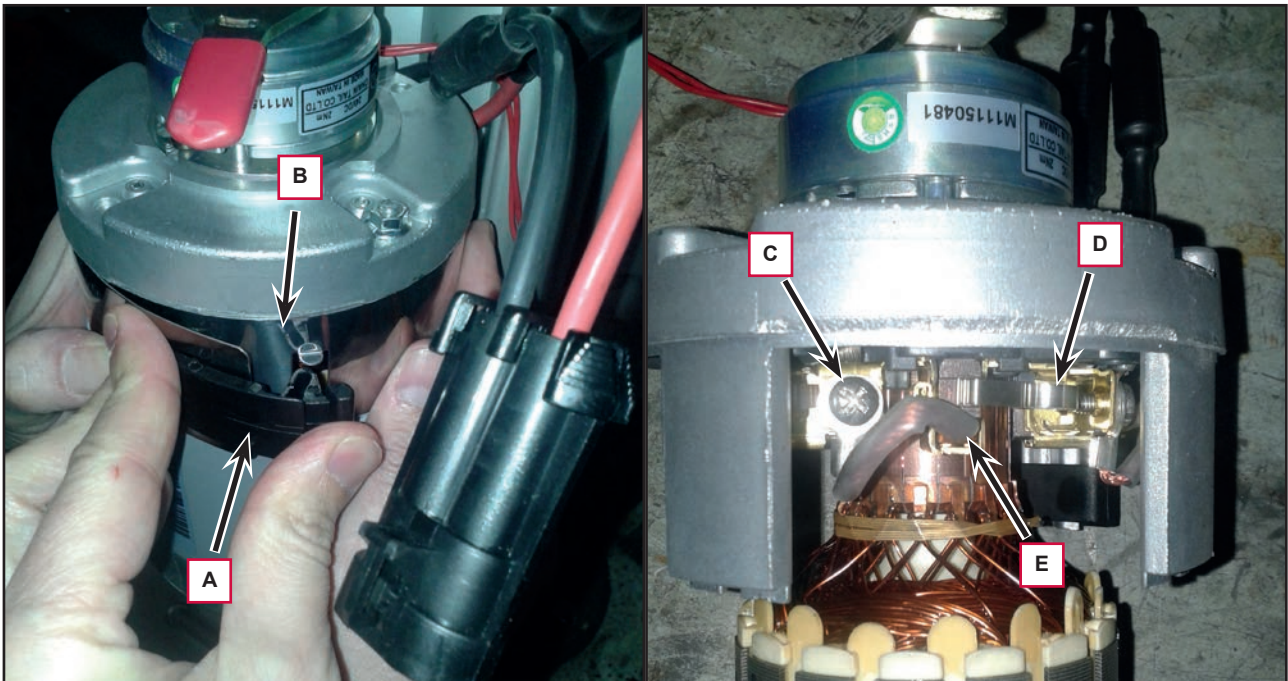


Figure 8

## Drive System Motor Electromagnetic Brake Disassembly/Assembly

### Disassembly

1. Remove the gearmotor unit from the machine.
2. At the workbench, remove dust and debris around the electromagnetic brake.
3. Remove the two screws (A, Figure 9) and the electromagnetic brake (B).

### Assembly

4. Assemble the components in the reverse order of disassembly, and note the following:
  - When assembling, place a screw (C) as reference.
  - Then install the electromagnetic brake, making sure that its hexagonal lining engages the hexagonal shaft (D) of the drive system motor.
5. Reassemble the gearmotor unit.

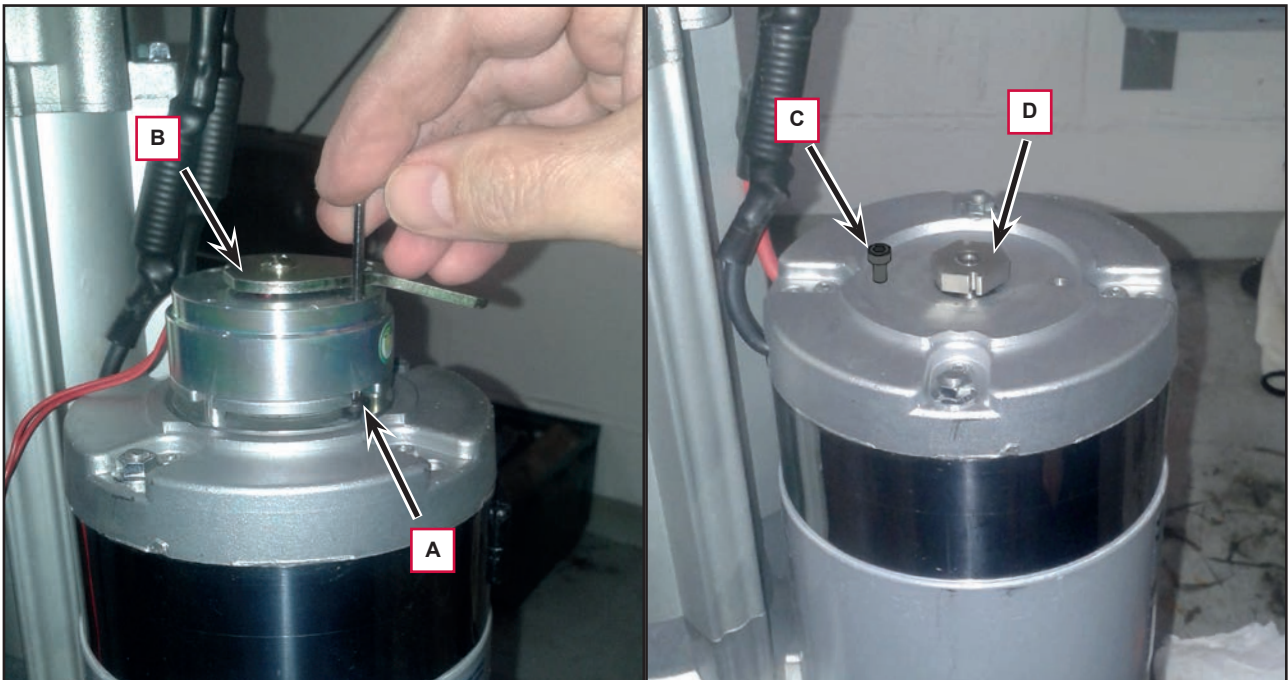


Figure 9

## Drive System Motor Disassembly/Assembly

### Disassembly

1. Remove the gearmotor unit from the machine.
2. At the workbench, remove dust and debris from the drive system motor.
3. Remove the clamp (A, Figure 10) by disengaging the tab (B).
4. Remove the two nuts (C), carefully remove the motor armature (D) from the stator cylinder (E).
5. Retrieve the retaining ring (F).

### Assembly

6. Assemble the components in the reverse order of disassembly, and note the following:
  - Remove any dust or dirt from the stator and removed components.
  - Before reinstalling the motor armature (D), apply grease on the retaining ring lip (F).
  - Check that the bearings of the motor armature (D) are properly installed on the shaft.
7. Reassemble the gearmotor unit.

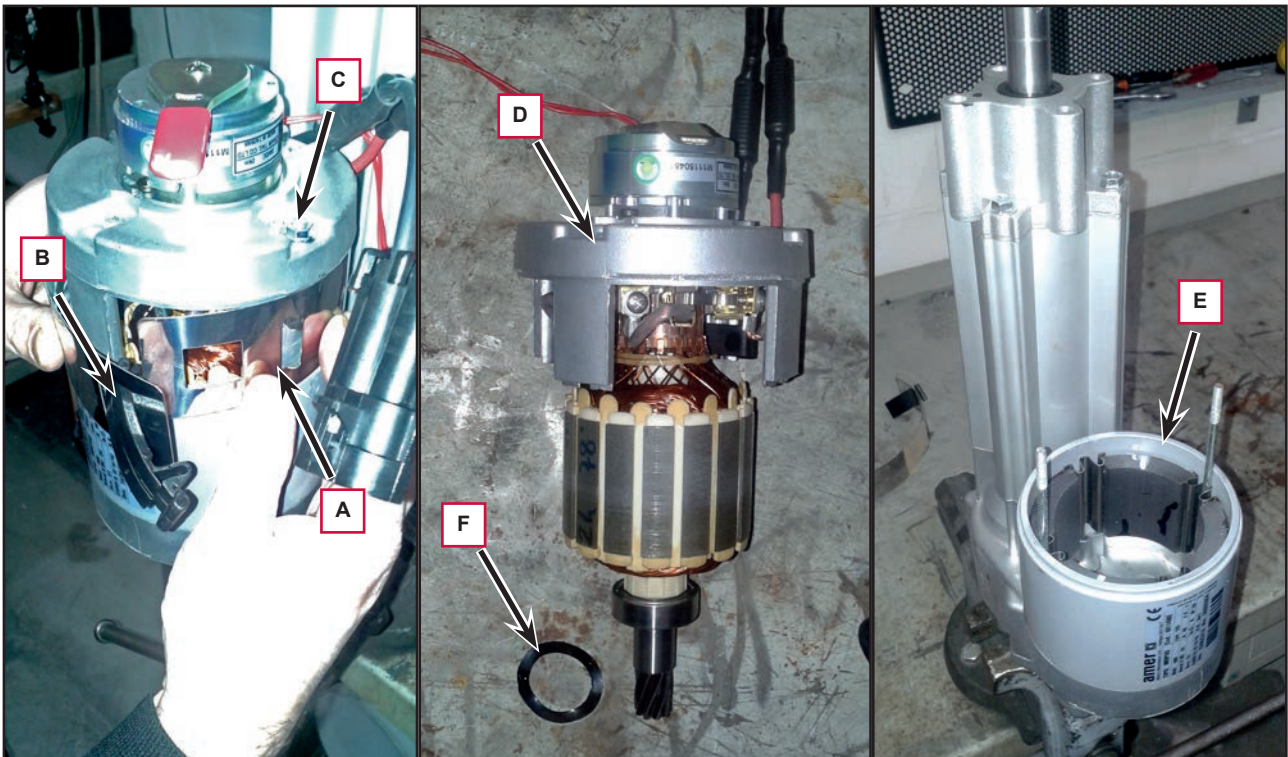


Figure 10

## Specifications

| Description / Model                                   |                    | Nilfisk<br>Scubtec R253          | Nilfisk<br>Scubtec R253 full PKG<br>Clarke RA40 |
|---|--------------------|----------------------------------|---|
| Rear driving wheel diameter                           |                    | 10 in (254 mm)                   |   |
| Rear driving wheel specific pressure on the floor (*) |                    | 145 psi (1.0 N/mm <sup>2</sup> ) |   |
| Driving wheel technical data                          | Power              | 0.53 hp (400 W)                  |   |
|   | Voltage            | 24V                              |   |
|   | Transmission ratio | 26:1                             |   |
|   | Protection class   | IP44                             |   |
|   | Insulation class   | F                                |   |
| Drive speed (variable)                                |                    | 0 - 3.7 mi/h (0 - 6 km/h)        |   |
| Maximum gradient when working                         |                    | 2 %                              |   |

(\*) Machines have been tested under the following conditions:

- Battery maximum size
- Maximum brush and squeegee size
- Full detergent tank
- Optional equipment installed
- Wheel weight checked
- Print on the floor checked on cement for each single wheel
- Result expressed as maximum value for rear wheels